



***MACHETA[®] AIRFOIL PROPELLER
MANCOOLERS***



**Steeler Mancooler
Model STL**

Design Features

*Utility
Mancooler
(UM)*



*Pedestal
Mount
Mancooler
(PUM)*

*Model 39
Mancooler
(M39)*

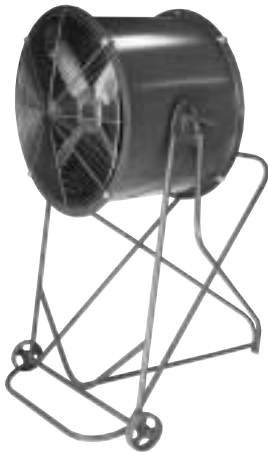

*Steeler
Mancooler
(STL)*

Utility Mancooler

Aerovent's Utility Mancoolers feature a quality, general purpose direct drive tubeaxial fan with the Macheta® airfoil propeller and front and rear PMS type guards for maximum protection and safety. The Utility Mancooler is mounted on a heavy duty tubular base with reinforcing gussets that act as mounting pads. The design enables the fan to operate on the floor as a free-standing unit or to be rotated in its base and mounted on the wall. The unit can also be supplied with optional locking wheels where fan mobility is required. Air delivery can be adjusted through 360°. Typical applications for the Utility Mancooler include welding booth and control panel ventilation, insect chasing, process cooling and smoke dissipation.

Pedestal Mount Mancooler

The Pedestal Mount Mancooler is an alternative to the standard Utility Mancooler model. The Pedestal Mount Mancooler uses a yoke assembly mounted on a predrilled mounting pad. The pedestal and yoke design enables the fan to be rotated and mounted in any position or location (i.e., on steel columns or ceiling beams). Pedestal Mount Mancoolers are available in the same sizes as the standard Utility Mancooler model. Specify pedestal mount when ordering

Model 39 Mancooler

Adaptability and portability are the main features of the Model 39 Mancooler. The unit features a general purpose direct drive tubeaxial fan mounted in an adjustable lightweight tubular steel frame. The Model 39 Mancooler features front and rear PMS type guards for maximum protection and safety. Air delivery is adjustable through 180°. All Model 39 Mancoolers come equipped with a set of front wheels to easily relocate the fan where needed.

Steeler Mancooler

Some industries require mancooler fans that can withstand rough handling. The "Steeler" is specifically designed and built for heavy duty industrial use. Developed for steel mills, the "Steeler" Mancooler fan can be moved about as required — rolled on rough floors or moved by crane from one spot to another. To withstand this punishment, the tubeaxial section is banded with two extra angle rings around the middle to protect the fan motor. Guards are 14-gauge expanded metal type, and the support legs are structural angle iron with two steel locking wheels and two steel caster wheels for maneuverability. Air delivery can be adjusted through 180°. A lifting eye is provided for hoisting the fan from one location to another with a crane hook.

Performance Data

Utility, Pedestal Mount and Model 39 Mancoolers

SIZE	CATALOG NUMBER				CFM**
	PROP	FAN TYPE	RPM	HP	
*16"	16L432	UM / PUM	1750	1/4	3000
*18"	18L430	UM / PUM	1750	1/3	3943
	18L432	UM / PUM	1750	1/2	4190
*21"	21L420	UM / PUM	1750	1/3	4774
	21L424	UM / PUM	1750	1/2	5512
	21L430	UM / PUM	1750	3/4	6262
24"	21L432	UM / PUM	1750	1	6654
	24L428	UM / M39 / PUM	1160	1/2	6604
	24L224	UM / M39 / PUM	1750	3/4	8155
	24L230	UM / M39 / PUM	1750	1	8955
27"	24L426	UM / M39 / PUM	1750	1 1/2	9464
	27M413	UM / M39 / PUM	1750	1/2	7292
	27M417	UM / M39 / PUM	1750	3/4	8902
30"	27M616	UM / M39 / PUM	1750	1	8960
	30L230	UM / M39 / PUM	1160	1	10688
	30L428	UM / M39 / PUM	1160	1 1/2	12899
	30L218	UM / M39 / PUM	1750	1 1/2	13879
32"	30L222	UM / M39 / PUM	1750	2	14611
	32M616	UM / M39 / PUM	1160	1	10868
36"	32M417	UM / M39 / PUM	1750	2	15242
	36L218	UM / M39 / PUM	1160	1	15291
	36L224	UM / M39 / PUM	1160	1 1/2	18435
	36L228	UM / M39 / PUM	1160	2	20048
	36L212	UM / M39 / PUM	1750	2	17932
	36L216	UM / M39 / PUM	1750	3	21287
42"	36L224	UM / M39 / PUM	1750	5	27811
	42L422	UM / M39 / PUM	870	2	23597
	42L428	UM / M39 / PUM	870	3	27136
	42L422	UM / M39 / PUM	1160	5	31463
48"	42L428	UM / M39 / PUM	1160	7 1/2	36182
	42L218	UM / M39 / PUM	1750	7 1/2	36578

**Performances shown do not include guard losses.

*Model 39 Mancoolers are only available in sizes 24-42.

Steeler Mancooler

SIZE	CATALOG NUMBER				CFM**
	PROP	FAN TYPE	RPM	HP	
24"	24L230	STL	1750	1	8955
	24L426	STL	1750	1 1/2	9464
30"	30L230	STL	1160	1	10688
	30L428	STL	1160	1 1/2	12899
	30L218	STL	1750	1 1/2	13879
	30L222	STL	1750	2	14611
36"	36L218	STL	1160	1	15291
	36L224	STL	1160	1 1/2	18435
	36L228	STL	1160	2	20048
	36L212	STL	1750	2	17932
	36L216	STL	1750	3	21287
42"	36L224	STL	1750	5	27811
	42L422	STL	1160	5	31463
	42L428	STL	1160	7 1/2	36182
48"	42L218	STL	1750	7 1/2	36578
	48L226	STL	1160	7 1/2	45158
48"	48L422	STL	1160	10	46913

**Performances shown do not include guard losses.

Catalog Numbering System

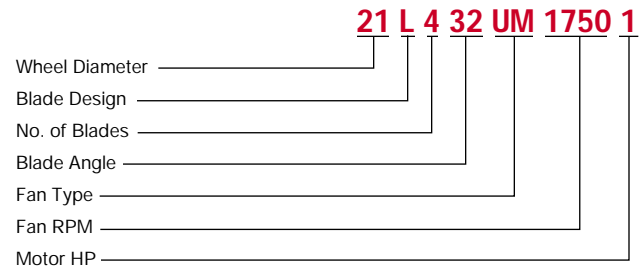

Specifications

CONSTRUCTION — Macheta® Airfoil Mancoolers, where indicated on drawings and schedules, shall be direct drive. Mancoolers shall be manufactured by Aerovent, Minneapolis, Minnesota, and shall be of the size and capacity as indicated in the fan schedule. Macheta® Airfoil Mancoolers shall be tested and rated in accordance with industry test codes and are guaranteed by the manufacturer to deliver at the rated published performance levels. In addition, each unit shall be run tested prior to shipment. Fan housing shall be rolled and flanged from heavy-gauge steel with a continuous welded seam. Standard units are supported on a heavy duty tubular base with reinforcing gussets and mounting pads. OSHA type guards, front and rear, shall be bolted to the fan housing. Standard units can be rotated through 360°. Unit shall have provisions for locking wheels, wall mount, column mount or stationary mount.

PROPELLERS — Precision Macheta® tipped airfoil propellers shall be of A319 cast aluminum. The propeller shall be secured to the motor shaft with knurled cup point setscrews on size 16" and split taper lock bushings on sizes 18" and larger.

BALANCING — The propeller assembly shall be statically and dynamically balanced in accordance with ANSI/AMCA 204-96 "Balance Quality and Vibration Levels for Fans" to Fan Application Category BV-3, Balance Quality Grade G6.3. In addition, direct drive fan propellers shall be balanced on the motor shaft after final assembly in the fan casing, in the manufacturing facility, to the following peak velocity values, filter-in, at the fan test speed:

Fan Application Category	Rigidly Mounted (in./s)	Flexibly Mounted (in /s)
BV-3	0.15	0.20

MOTORS — Fan motors shall be foot mounted NEMA Design B, standard industrial continuous duty, ball bearing (ODP, TEAO, TEFC, FCXP) variable torque type suitable for operation on voltage, phase and hertz, as listed in the fan schedule.

FINISH — The unit, after fabrication, shall be cleaned and chemically pretreated by a phosphatizing process and shall be painted inside and outside with an air dry enamel.

ACCESSORIES — Unit shall be complete with: Locking Wheels (UM Mancoolers only)

Dimensional Data

Utility Mancooler

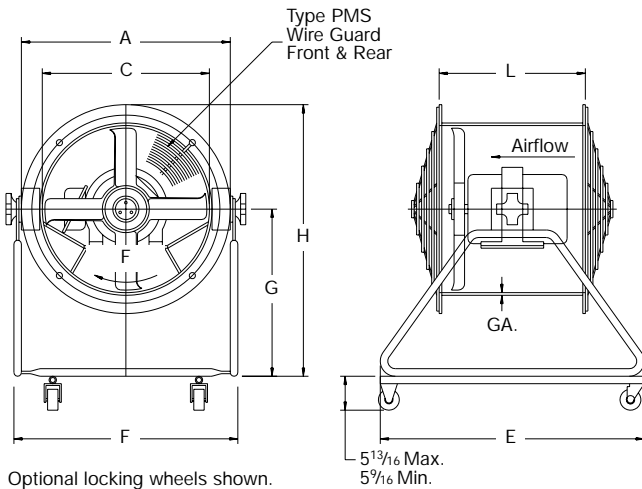

SIZE	A	C	E	F	G	H	L	GA.
16	19	16 ¹ / ₄	21 ³ / ₄	21 ⁷ / ₈	15 ³ / ₄	25 ¹ / ₄	15	.105
18	21	18 ¹ / ₄	21 ³ / ₄	23 ⁷ / ₈	15 ³ / ₄	26 ¹ / ₄	15	.105
21	24	21 ¹ / ₄	21 ³ / ₄	26 ⁷ / ₈	15 ³ / ₄	27 ³ / ₄	15	.105
24	27	24 ¹ / ₄	32	30 ¹ / ₂	22	35 ¹ / ₂	18	.105
27	30 ¹ / ₄	27 ¹ / ₄	32	33 ¹ / ₂	22	37 ⁷ / ₈	18	.105
30	33 ¹ / ₄	30 ¹ / ₄	32	36 ¹ / ₂	22	38 ⁵ / ₈	24	.105
32	35 ¹ / ₂	32 ¹ / ₂	32	38 ³ / ₄	22	39 ³ / ₄	24	.105
36	39 ¹ / ₂	36 ¹ / ₂	44	42 ³ / ₄	28	47 ³ / ₄	26	.105
42	46	42 ³ / ₄	44	49	28	51	26	.135

Pedestal Mount

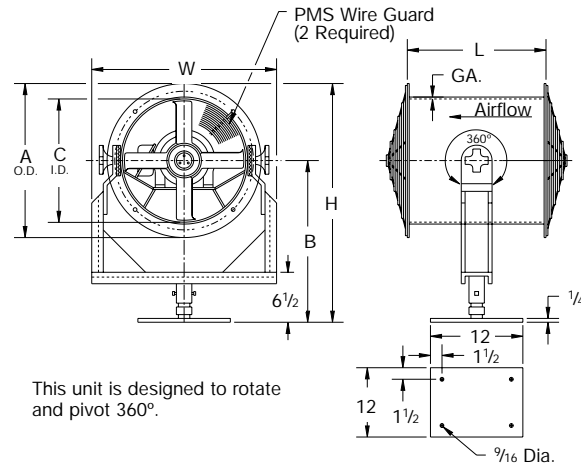

SIZE	A	B	C	H	L	W	GA.
16	19	21	16 ¹ / ₄	30 ¹ / ₂	15	23 ³ / ₈	.105
18	21	22	18 ¹ / ₄	32 ¹ / ₂	15	25 ⁵ / ₈	.105
21	24	24	21 ¹ / ₄	36	15	28 ¹ / ₂	.105
24	27	25	24 ¹ / ₄	38 ¹ / ₂	18	31 ¹ / ₂	.105
27	30 ¹ / ₄	27	27 ¹ / ₄	42 ⁷ / ₈	18	34 ¹ / ₂	.105
30	33 ¹ / ₄	29	30 ¹ / ₄	45 ⁵ / ₈	24	37 ¹ / ₂	.105
32	35 ¹ / ₂	30	32 ¹ / ₂	47 ³ / ₄	24	41 ⁵ / ₈	.105
36	39 ¹ / ₂	32	36 ¹ / ₂	51 ³ / ₄	26	45 ⁵ / ₈	.105
42	46	35	42 ³ / ₄	58	26	51 ⁷ / ₈	.135

Steeler Mancooler

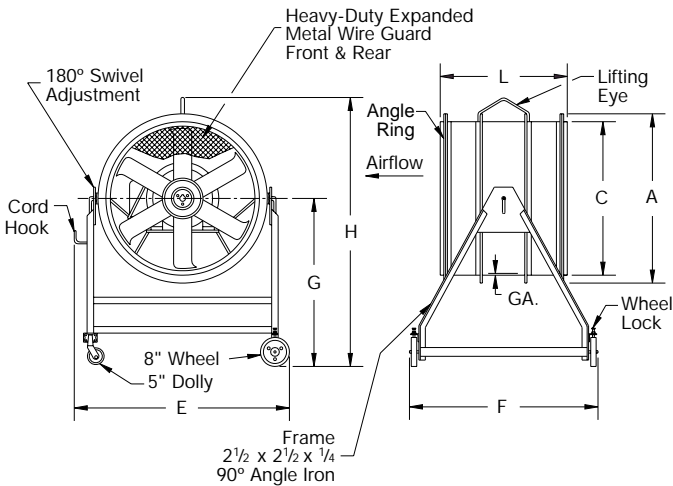

SIZE	A	C	E	F	G	H	L	ANGLE RING	GA.
24	27	24 ³ / ₈	41	38 ¹ / ₄	36	59 ¹ / ₄	20 ¹ / ₂	1 ¹ / ₄ x 1 ¹ / ₄ x 1 ¹ / ₈	.075
30	33	30 ³ / ₈	47 ¹ / ₂	38 ¹ / ₄	42	68 ¹ / ₂	26 ¹ / ₂	1 ¹ / ₄ x 1 ¹ / ₄ x 1 ¹ / ₈	.075
36	39 ¹ / ₂	36 ⁷ / ₈	53 ¹ / ₂	38 ¹ / ₄	42	71 ³ / ₄	26 ¹ / ₂	1 ¹ / ₄ x 1 ¹ / ₄ x 1 ¹ / ₈	.075
42	46	42 ³ / ₄	59 ¹ / ₂	40 ¹ / ₄	48	80 ³ / ₄	29	1 ¹ / ₂ x 1 ¹ / ₂ x 3 ³ / ₁₆	.105
48	52	48 ³ / ₄	65 ¹ / ₂	44 ¹ / ₄	48	83 ³ / ₄	33	1 ¹ / ₂ x 1 ¹ / ₂ x 3 ³ / ₁₆	.105

Model 39

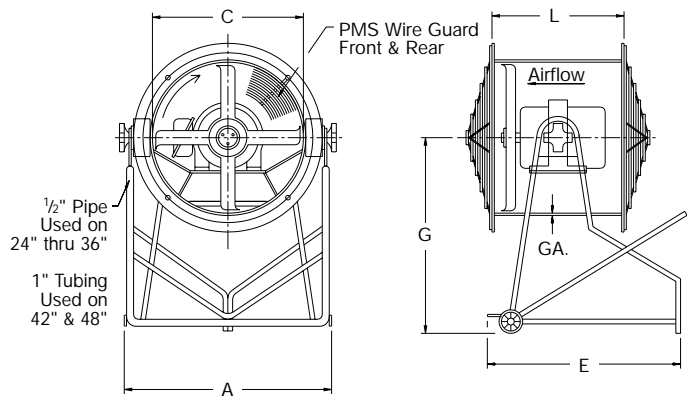

SIZE	A	C	E	G	L	GA.
24	33	24 ¹ / ₄	40 ⁷ / ₈	41 ¹ / ₂	18	.105
27	35 ⁷ / ₈	27 ¹ / ₄	40 ⁷ / ₈	41 ¹ / ₂	18	.105
30	39	30 ¹ / ₄	40 ⁷ / ₈	41 ¹ / ₂	24	.105
32	41 ¹ / ₈	32 ¹ / ₂	40 ⁷ / ₈	41 ¹ / ₂	24	.105
36	45	36 ¹ / ₂	40 ⁷ / ₈	41 ¹ / ₂	26	.105
42	51 ⁵ / ₁₆	42 ³ / ₄	40 ⁷ / ₈	41 ¹ / ₂	26	.135

Dimensions are in inches unless otherwise noted.
Dimensions are not to be used for construction.



Aerovent

A Twin City Fan Company

3MPP04/03

5959 Trenton Lane · Minneapolis, MN 55442-3238

Phone (763)551-7500 · Fax (763)551-7501 · www.aerovent.com

