



CENTAXIAL[®] TUBULAR CENTRIFUGAL FANS

BELT DRIVEN / DIRECT DRIVE

***BIA Airfoil Blade Design
Class I, II, III***



**Model CBD
(Belt Driven)**



**Model CDD
(Direct Drive)**

Centaxial® Tubular Centrifugal Fans

The Aerovent Centaxial® fan is a tubular centrifugal fan offering a compact design, stable performance, quiet operation, and low operating cost. Its construction combines the advantages of the axial flow fan with performance and application characteristics similar to a centrifugal fan. The Centaxial® is designed to provide straight-through airflow and can be installed directly in a straight duct having the same size and shape inlet and outlet. This advanced design saves more than half the space required by a scroll-type centrifugal fan. It is lighter, making it less expensive and easier to install.

The Centaxial® is not a modification of the centrifugal fan or a variation of the vaneaxial fan. It would most adequately be described as a mixed-flow fan. The common mixed-flow propeller has been used mostly in high capacity pumps. The physical design of the ordinary mixed-flow wheel made its use rather limited; however, the development of the airfoil centrifugal wheel has led to the design of the Centaxial® fan, in which the airflow pattern is almost the same as the flow of fluid through a mixed-flow pump.

Since first offering the Centaxial® design in 1963, Aerovent research and development has brought about a significant improvement in efficiency. The wheels in all sizes are backward curved airfoil design, providing stable performance, quiet operation and more air per horsepower.



*Model CBD
Belt Driven*

Sizes and Capacities

- Belt Driven Sizes 12" to 71"
- Direct Drive Sizes 12" to 44"
- Capacities to 130,000 CFM
- Static Pressures to 14"

Applications

Aerovent Centaxial® fans are designed for continuous duty in air moving systems handling clean air. Typical applications would be:

- Industrial space ventilation exhaust or supply
- Industrial fume ventilation (where a suitable coating has been applied if the fumes are corrosive)
- Air make-up
- Air conditioning
- Evaporative cooling
- Heat recovery systems
- As an exhaust fan on the clean air side of certain types of collectors and scrubbers



*Model CDD
Direct Drive*

Contents

Applications	2
Construction Features	3
Accessories	4
Optional Construction	6
Drive Arrangements	7
Engineering Data	8
Performance Data	9
Dimensional Data	23
Typical Specifications	26

Certification



Aerovent certifies that the Centaxial® Tubular Centrifugal Fans shown herein are licensed to bear the AMCA Seal. The Ratings shown are based on tests and procedures performed in accordance with AMCA Publication 211 and Publication 311 and comply with the requirements of the AMCA Certified Ratings Program.

Refer to Bulletin 338 for sound power levels.

©2004 Aerovent, Twin City Fan Companies, Ltd.
Bulletin illustrations cover the general appearance of Aerovent products at the time of publication and we reserve the right to make changes in design and construction at any time without notice.

Construction Features

The Centaxial® fan casing is rolled welded steel with aluminum or stainless steel available as an option. The inner shell is held in place by heavy gauge guide vanes, which also support the pillow block ball bearing mountings. The motor mount is sturdy and provides for adjustment of belt tension. Bearings and shafts are sized to cover a wide range of speed and horsepower. The entrance orifice is built into the housing to provide optimal flow into the fan wheel. Mounting flanges are capable of supporting the fan in ductwork. The mounting flanges at the inlet and outlet are the same size for easy installation in a straight-line duct system.

Aerovent Centaxial® fans are designed with the bearings selected for horizontal installation. They may or may not be suitable for vertical installation, particularly in the larger sizes utilizing spherical roller bearings (see material specifications on page 8). If the fan is to be mounted in the vertical position, contact the factory for availability and pricing. Performance characteristics and direction of airflow are required for proper selection.

BIA Wheel

The BIA wheel features a backward curved airfoil blade design. This wheel offers the same power limiting characteristics of the BI wheel, but has the added advantage of higher operating efficiencies and lower noise levels. The BIA wheel is limited primarily to clean air applications.

Wheel sizes 12" through 25" are finished in welded aluminum construction only. All other sizes are furnished in steel construction as standard with aluminum as an option. An optional BI wheel is also available.



Standard Construction. Note belt tube, which isolates belts from airstream. Extended grease fittings are also visible.

Optional High Temperature Construction

Belt driven Centaxial fans especially designed for high temperature operations are available from size 25 to 71 in all-steel construction, in either standard "C" or "TC" types, to handle air temperatures up to 600°F. Protection of the bearings and the drive is accomplished by an auxiliary forced-air cooling system, using a 9" propeller fan to ventilate the inner housing, in which the drive is completely enclosed.

Heat fans can be offered in the smaller sizes, but require special construction. Contact the factory for details.



High Temp Construction

Optional Type TC Construction

A modified inlet and discharge may be added to make these areas the same as a scroll-type centrifugal fan of the same wheel size. This enables the user to directly replace a scroll fan with a Centaxial® fan.

Although this fan design is slightly more expensive, it has certain advantages which make it desirable for some installations. The "TC" design will fit directly into smaller diameter duct systems at a considerable savings in installation cost. The addition of the tapered discharge cone does not appreciably decrease the efficiency of the fan. The illustration below shows the Centaxial® fan with the optional tapered discharge cone and smaller inlet connections.



Type TC Construction

Accessories

Silencers



For particularly quiet operation, Aerovent silencers provide an aerodynamically, acoustically matched package. They significantly reduce noise and add only minor resistance to airflow. Flange connections on both inlet and outlet ends

couple directly to the Centaxial® fan. Silencers may be added to inlet and discharge flanges for minimum noise. Consult factory for insertion loss (dB) and resistance data.

Support Legs

Support legs are available for standard platform or floor mounting. The support legs are bolted to the inlet and discharge flange rings.



Shaft Seals

Four types of friction shaft seals are available:

1. Elastomeric Rotary Seal — Recommended to protect the shaft and bearings when the fan is used for handling dirty, wet, or corrosive air. The seal rides against a heavy Teflon wear plate. This seal is suitable for operation to 300°F.
2. Ceramic Felt — Best suited for 301°F to 800°F operation. These seals minimize leakage around the shaft opening but are not gas tight. Elements are encased between the housing drive side and a metal retaining plate. Ceramic felt inserts may be easily split for field installation and maintenance.
3. Lubricated Seals — For longer seal life. Suitable to 300°F.
4. Stuffing Boxes — For maximum sealing. Specify temperature for proper packing material.



Fan Safety Guards

OSHA safety guards are available for either the inlet or discharge end of the fan. The design may vary depending upon the diameter and functional requirement.



Inlet Dampers

The vortex damper controls air volume while reducing horsepower. It imparts a swirl to the air in the direction of wheel rotation. The graph indicates the angle of the damper setting related to the reduction in air volume and horsepower.

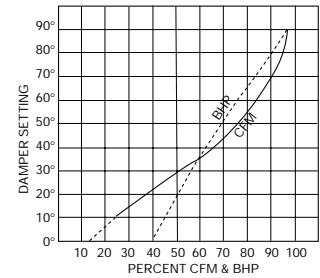

Vibration Isolators

Rubber-in-shear or spring type vibration isolators are available for all sizes and arrangements. Individual pads will be furnished as standard. If rails or rail assemblies are required, consult the factory for specifications and pricing.



Floor Mount



Ceiling Mount



Accessories

Ceiling Suspension Brackets

Mounting pads for use with vibration isolators are available for horizontal ceiling suspension.



Vertical Mounting Brackets

Mounting pad sections for use with vibration isolators are available and may be provided for vertical or suspended installation.

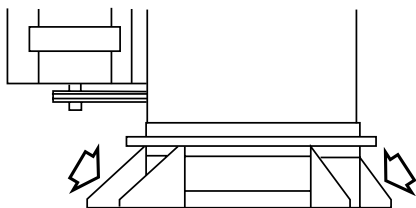

Belt Guards

OSHA belt guards covering the motor sheave and belts outside the Centaxial® fan are mounted directly to the fan housing.



Wheel Inspection Door

Access to inspect wheel with limited space for cleaning the wheel.

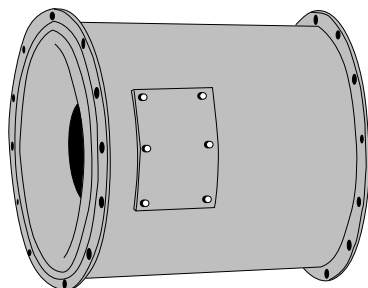

Stack Caps

For use with vertical discharge through the roof. These heads have backdraft dampers and can be furnished with protective coatings for handling corrosive fumes. A motorized unit is also available.



Minimum Outlet Velocity Required For Full Open Damper Operation:

Steel Dampers – 1700 FPM

Aluminum Dampers – 1300 FPM

Curb Bases

Roof ventilator bases for curb mounting may be used to convert the Centaxial® fan to a roof ventilator. A stack cap or other device on the discharge side is necessary for weather protection in installations of this type.



Motor Covers

OSHA motor covers are available for all models. Motor covers are vented, so it is necessary that the fan discharge arrangement be specified for proper drip-proof construction of the motor cover.



Optional Construction

Spark Resistant Construction

Described below are three classifications as defined by AMCA Standards for spark resistant construction.

Type	Construction Details
“A”	— All parts of the fan in contact with the air or gas being handled shall be made of nonferrous material. Steps must also be taken to ensure that the impeller, bearings, and shaft are adequately attached and/or restrained to prevent a lateral or axial shift in these components.
“B”	— The fan shall have a nonferrous impeller and nonferrous ring about the opening through which the shaft passes. Ferrous hubs, shafts, and hardware are allowed provided construction is such that a shift of impeller or shaft will not permit two ferrous parts of the fan to rub or strike. Steps must also be taken to ensure that the impeller, bearings, and shaft are adequately attached and/or restrained to prevent a lateral or axial shift in these components.
“C”	— The fan shall be so constructed that a shift of the impeller or shaft will not permit two ferrous parts of the fan to rub or strike.

NOTES:

1. No bearings, drive components, or electrical devices shall be placed in the air or a gas stream unless they are constructed or enclosed in such a manner that failure of that component cannot ignite the surrounding gas stream.
2. The user shall electrically ground all fan parts.
3. For this standard, nonferrous material shall be any material with less than 5% iron or any other material with demonstrated ability to be spark resistant.

4. The use of aluminum or aluminum alloys in the presence of steel, that have been allowed to rust, requires special consideration. Research, by the U.S. Bureau of Mines and others, has shown that aluminum impellers rubbing on rust steel may cause high intensity sparking.

The use of the above standard in no way implies a guarantee of safety for any level of spark resistance. “Spark resistant construction also does not protect against ignition of explosive gases caused by catastrophic failure or from any airstream material that may be present in a system.”

High Temperature Construction

Belt driven Centaxial fans especially designed for high temperature operations are available from size 25 to 71 in all-steel construction, in either standard “C” or “TC” types, to handle air temperatures up to 600°F. Protection of the bearings and the drive is accomplished by an auxiliary forced-air cooling system, using a 9” propeller fan to ventilate the inner housing, in which the drive is completely enclosed.

Heat fans can be offered in the smaller sizes, but require special construction. Contact the factory for details.

Corrosion Resistant Construction

Corrosion problems result when the air contains one or more chemicals that are corrosive in nature. The extent of the corrosion problem, however, varies with the specific properties of the chemical involved, as well as the concentration, moisture, and temperature of the mixture. Protective coatings and special construction are available to combat corrosion problems. Contact the factory for more details.

Special Materials

The Model CBD housing is constructed of steel as standard but is available in aluminum, stainless steel, or special coatings.

Drive Arrangements

Belt Driven Arrangements (CBD)

Arrangement 1

Belt driven Arrangement 1 is recommended when large horsepower motors are required. The wheel is overhung on the shaft, supported by heavy duty bearings that are mounted within the inner shell of the fan. The motor is mounted independent of the fan housing on structural channel support legs.

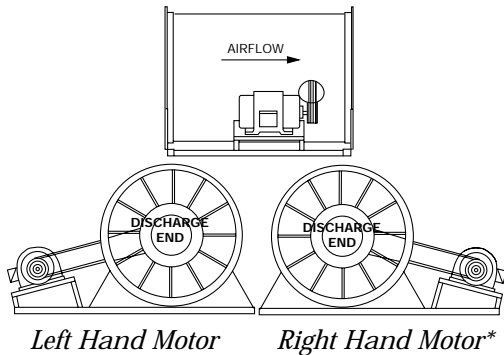

Arrangement 9RV**

Arrangement 9RV is the standard belt driven Arrangement 9 fan with a stack cap, curb base and weather cover for the motor and drives. Available in all sizes, the Centaxial® roof ventilator is an extremely quiet and efficient roof exhauster.

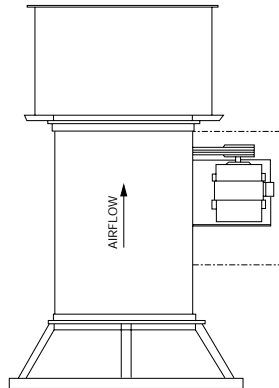

***Consult the factory for vertical mounts requiring motors with frames larger than listed in the table on page 21 and on size 49 and larger Class III fans.*

Arrangement 9

Standard belt driven Arrangement 9 is recommended for most belt driven applications. The wheel is overhung on the shaft and supported by bearings mounted within the inner shell of the fan. Suitable for duct, vertical, or horizontal mounting.

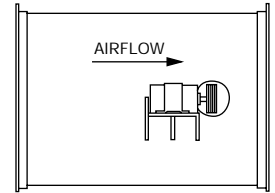

Horizontal Floor Positions

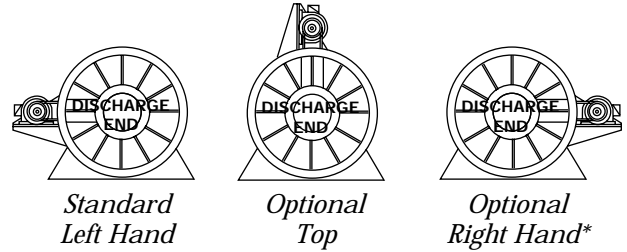

Horizontal Ceiling Positions

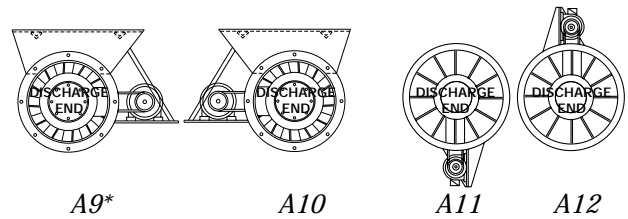

Vertical Floor Positions

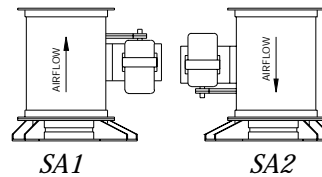

Vertical Ceiling Positions

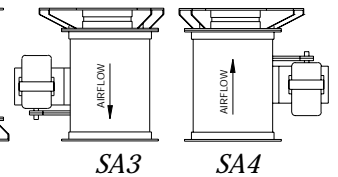

**Requires F2 motor mount.*

Direct Drive Arrangement 4 (CDD)

The Arrangement 4 offers compact assembly for duct mounting in tight enclosures, eliminating the motor overhang required on belt driven units.

Vertical Discharge Positions

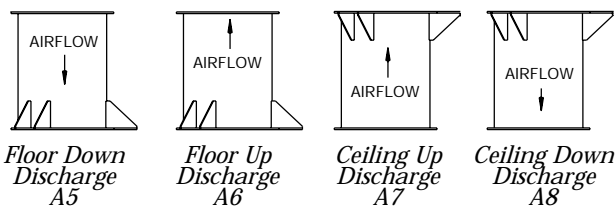

Ceiling Horizontal Discharge Position

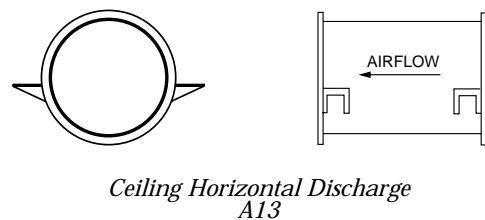

Engineering Data

Material Specifications

SIZE (IN.)	HORIZONTAL INSTALLATION			VERTICAL INSTALLATION			HOUSING GAUGE		WHEEL WEIGHT (LBS.)		
	CLASS I	CLASS II	CLASS III	CLASS I	CLASS II	CLASS III	INNER SHELL	OUTER SHELL	CLASS I	CLASS II	CLASS III
12	3/4"	1 3/16"	1 3/16"	3/4"	1 3/16"	1 1/2"	12 GA	14 GA	10	10	10
14	3/4"	1 3/16"	1 1/2"	1"	1 1/2"	*1 1/2"	12 GA	14 GA	14	14	14
16	1"	1 1/2"	*1 1/2"	1 3/16"	1 1/2"	*1 1/2"	12 GA	14 GA	15	15	15
18	1 3/16"	1 1/2"	*1 1/2"	1 1/2"	1 1/2"	*1 1/2"	12 GA	14 GA	23	23	23
20	1 3/16"	1 1/2"	*1 1/2"	1 1/2"	*1 1/2"	*1 1/2"	12 GA	14 GA	27	27	27
22	1 1/2"	*1 1/2"	*1 1/2"	1 1/2"	*1 1/2"	*1 1/2"	12 GA	14 GA	50	50	50
25	1 1/2"	*1 1/2"	*1 1/2"	*1 1/2"	*1 1/2"	*1 1/2"	12 GA	12 GA	56	56	59
28	1 1/2"	*1 1/2"	*1 1/2"	*1 1/2"	*1 1/2"	*1 1/2"	12 GA	12 GA	114	114	120
32	1 15/16"	*1 15/16"	*1 15/16"	*1 15/16"	*1 15/16"	*1 15/16"	10 GA	12 GA	181	181	190
35	2 3/16"	*2 3/16"	*2 3/16"	*2 3/16"	*2 3/16"	*2 3/16"	10 GA	12 GA	248	248	259
39	2 3/16"	*2 3/16"	*2 3/16"	*2 3/16"	*2 3/16"	*2 3/16"	10 GA	12 GA	386	386	400
44	2 7/16"	*2 7/16"	*2 7/16"	*2 7/16"	*2 7/16"	*2 7/16"	10 GA	10 GA	404	404	422
49	*2 7/16"	*2 7/16"	*2 7/16"	*2 7/16"	*2 7/16"	*2 7/16"	10 GA	10 GA	412	731	731
55	*2 7/16"	*2 7/16"	*2 7/16"	*2 7/16"	*2 7/16"	*2 7/16"	7 GA	10 GA	821	846	846
63	*2 15/16"	*2 15/16"	*2 15/16"	*2 15/16"	*2 15/16"	*2 15/16"	7 GA	10 GA	987	1019	1019
71	*3 7/16"	*3 7/16"	*3 7/16"	*3 7/16"	*3 7/16"	*3 7/16"	7 GA	10 GA	1506	1616	1616

*Denotes spherical roller bearings

WR² Factors of BIA and BI Wheels (moment of inertia in lb-ft²)

SIZE (IN.)	BIA WHEELS						BI WHEELS					
	CLASS I		CLASS II		CLASS III		CLASS I		CLASS II		CLASS III	
	ALUM.	STEEL	ALUM.	STEEL	ALUM.	STEEL	ALUM.	STEEL	ALUM.	STEEL	ALUM.	STEEL
12	1	—	1	—	1	—	1	2	1	2	1	3
14	2	—	2	—	2	—	2	4	2	4	2	4
16	3	—	3	—	3	—	2	5	2	5	3	6
18	6	—	6	—	6	—	4	10	4	10	5	11
20	9	—	9	—	9	—	7	16	7	16	7	17
22	21	—	21	—	21	—	15	34	15	34	17	38
25	26	—	26	—	27	—	23	53	23	53	25	56
28	46	94	46	94	48	99	34	78	34	78	36	83
32	71	149	71	149	94	157	65	154	79	177	79	177
35	122	266	122	266	128	277	114	260	123	280	123	280
39	202	443	202	443	210	460	217	504	231	533	231	533
44	366	683	366	683	376	714	365	717	403	820	403	820
49	591	1500	609	1541	609	1541	595	1458	623	1547	623	1547
55	855	2171	884	2237	884	2237	861	2110	907	2250	907	2250
63	1356	3408	1404	3519	1404	3519	1439	3570	1439	3570	1439	3570
71	2574	6583	2771	7063	2771	7063	2544	6316	2544	6316	2544	6316

Maximum Safe Speed Factors for BIA and BI Alloy Wheel Construction at Elevated Temperatures

MATERIAL	-50°	70°	200°	300°	400°	500°	600°
STEEL	1.00	1.00	0.97	0.95	0.94	0.93	0.92
ALUMINUM	1.00	1.00	0.98	—	—	—	—
304 S.S. (BI ONLY)	1.00	1.00	0.88	0.82	0.78	0.75	0.73
316 S.S. (BI ONLY)	1.00	1.00	0.95	0.92	0.89	0.86	0.84
347 S.S. (BI ONLY)	1.00	1.00	0.95	0.93	0.90	0.90	0.90

Note: For temperatures other than 70°F, multiply the "Maximum Safe Speed Factor" for the operating temperature by the "Maximum Safe Wheel Speed at 70°F" to determine the maximum safe RPM at the operating temperature.

Stainless steel wheels are available in BI only.

Maximum Safe BIA & BI Wheel Speed at 70°F

SIZE (IN.)	BIA WHEELS			BI WHEELS		
	CL I	CL II	CL III	CL I	CL II	CL III
*12	3338	4406	5591	3080	4005	5083
*14	3006	3909	4962	2732	3554	4511
*16	2668	3468	4402	2425	3153	4002
*18	2371	3082	3913	2156	2802	3557
*20	2135	2775	3522	1941	2523	3202
*22	1906	2477	3144	1732	2252	2858
25	1663	2202	2795	1540	2002	2541
28	1476	1919	2435	1367	1777	2255
32	1310	1671	2160	1213	1576	2000
35	1164	1486	1921	1078	1402	1779
39	1028	1337	1696	970	1261	1600
44	918	1194	1515	866	1126	1429
49	823	1070	1358	776	1009	1281
55	735	955	1212	693	901	1143
63	642	835	1060	606	788	1000
71	571	742	942	539	701	889

*Aluminum wheels only for BIA — all others steel as standard.

Performance Data – CBD

Capacities shown in the performance tables that follow are for standard air conditions: 70°F at sea level (.075 lbs./cu. ft. air density).

Safe operating speed limits for various temperature conditions are shown in the tables on page 8.

The performance tables shown are given in English units.

Catalog Numbering System

To identify a specific fan for ordering or engineering specification, it is necessary to show the complete catalog number as outlined in the example below.

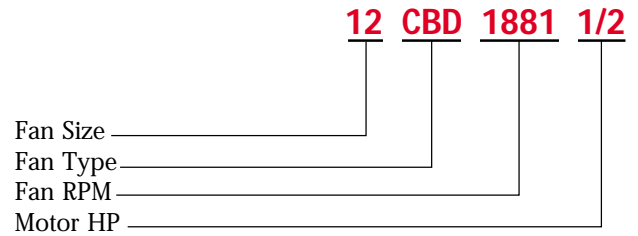

Size 12 CBD Belt Driven Centaxial

Wheel Diameter: 12.40"

Tip Speed, FPM = 3.25 x Fan RPM

Max. BHP = 0.055 x (RPM ÷ 1000)³

Inlet Diameter: 18.69"

Inlet Area: 1.91 ft.²

Outlet Area: 1.91 ft.²

LEGEND	
Class I fans = regular face	(Max. 3388 RPM)
Class II fans = bold face	(Max. 4406 RPM)
Class III fans = <i>italic face</i>	(Max. 5591 RPM)
<u>Underlined</u> figures indicate maximum static efficiency.	

CFM	OV	0.5" SP		1" SP		1.5" SP		2" SP		2.5" SP		3" SP		3.5" SP		4" SP		5" SP	
		RPM	BHP	RPM	BHP	RPM	BHP	RPM	BHP	RPM	BHP	RPM	BHP	RPM	BHP	RPM	BHP	RPM	BHP
760	400	1266	0.11	1549	0.20	1808	0.31												
950	500	1420	0.14	1689	0.26	1911	0.38	2117	0.51	2324	0.66								
1140	600	1578	0.19	1844	0.33	2050	0.46	2237	0.61	2410	0.76	2582	0.93	2754	1.10				
1330	700	1754	0.24	1997	0.40	2203	0.56	2378	0.72	2541	0.89	2693	1.07	2840	1.25	2988	1.44	3282	1.84
1520	800	1939	0.32	2152	0.48	2359	0.67	2531	0.85	2685	1.04	2830	1.23	2967	1.42	3098	1.62	3356	2.05
1710	900	2128	0.41	2321	0.58	2510	0.78	2687	0.99	2839	1.20	2977	1.41	3108	1.62	3235	1.84	3471	2.28
1900	1000	2319	0.52	2499	0.71	2668	0.91	2839	1.14	2995	1.38	3132	1.61	3258	1.84	3378	2.07	3608	2.55
2090	1100	2513	0.64	2684	0.85	2838	1.06	2993	1.30	3147	1.56	3288	1.82	3414	2.08	3531	2.33	3750	2.84
2292	1200	2721	0.80	2883	1.03	3028	1.26	3167	1.50	3310	1.77	3449	2.06	3579	2.34	3697	2.62	3911	3.17
2470	1300	2906	0.96	3061	1.21	3199	1.46	3330	1.71	3460	1.98	3592	2.27	3721	2.58	3842	2.89	4057	3.49
2660	1400	3105	1.15	3252	1.43	3385	1.70	3509	1.96	3629	2.24	3751	2.53	3874	2.86	3994	3.19	4214	3.85
2850	1500	3305	1.38	3445	1.67	3574	1.96	3692	2.24	3805	2.53	3918	2.83	4031	3.15	4146	3.50	4366	4.21
3056	1600	3524	1.65	3656	1.96	3780	2.28	3894	2.59	4002	2.89	4107	3.20	4211	3.52	4318	3.87	<i>4530</i>	<i>4.62</i>
3420	1800	3912	2.22	4033	2.58	4148	2.93	4256	3.28	4357	3.62	<i>4454</i>	<i>3.96</i>	<i>4548</i>	<i>4.30</i>	<i>4641</i>	<i>4.65</i>	<i>4830</i>	<i>5.42</i>
3800	2000	4321	2.95	<i>4431</i>	<i>3.35</i>	<i>4537</i>	<i>3.74</i>	<i>4638</i>	<i>4.13</i>	<i>4734</i>	<i>4.52</i>	<i>4825</i>	<i>4.90</i>	<i>4913</i>	<i>5.28</i>	<i>4999</i>	<i>5.65</i>	<i>5167</i>	<i>6.43</i>
4180	2200	<i>4731</i>	<i>3.84</i>	<i>4833</i>	<i>4.28</i>	<i>4931</i>	<i>4.71</i>	<i>5025</i>	<i>5.14</i>	<i>5116</i>	<i>5.57</i>	<i>5203</i>	<i>6.00</i>	<i>5287</i>	<i>6.42</i>	<i>5367</i>	<i>6.83</i>	<i>5523</i>	<i>7.66</i>

CFM	OV	6" SP		7" SP		8" SP		9" SP		10" SP		11" SP		12" SP		13" SP		14" SP	
		RPM	BHP	RPM	BHP	RPM	BHP	RPM	BHP	RPM	BHP	RPM	BHP	RPM	BHP	RPM	BHP	RPM	BHP
1520	800	3615	2.50																
1710	900	3700	2.75	3931	3.25	4160	3.77												
1900	1000	3821	3.04	4028	3.56	4235	4.10	<i>4442</i>	<i>4.67</i>	<i>4647</i>	<i>5.25</i>								
2090	1100	3959	3.37	4154	3.91	4342	4.47	<i>4530</i>	<i>5.05</i>	<i>4719</i>	<i>5.66</i>	<i>4907</i>	<i>6.28</i>						
2292	1200	4110	3.74	4301	4.31	<i>4482</i>	<i>4.91</i>	<i>4656</i>	<i>5.51</i>	<i>4827</i>	<i>6.13</i>	<i>4998</i>	<i>6.77</i>						
2470	1300	4251	4.09	<i>4435</i>	<i>4.70</i>	<i>4613</i>	<i>5.32</i>	<i>4782</i>	<i>5.95</i>	<i>4945</i>	<i>6.60</i>	<i>5104</i>	<i>7.25</i>						
2660	1400	<i>4407</i>	<i>4.49</i>	<i>4585</i>	<i>5.13</i>	<i>4756</i>	<i>5.79</i>	<i>4922</i>	<i>6.45</i>	<i>5082</i>	<i>7.13</i>	<i>5236</i>	<i>7.82</i>						
2865	1500	<i>4576</i>	<i>4.95</i>	<i>4753</i>	<i>5.64</i>	<i>4919</i>	<i>6.33</i>	<i>5079</i>	<i>7.03</i>	<i>5234</i>	<i>7.74</i>	<i>5386</i>	<i>8.48</i>						
3056	1600	<i>4730</i>	<i>5.39</i>	<i>4911</i>	<i>6.14</i>	<i>5076</i>	<i>6.87</i>	<i>5232</i>	<i>7.61</i>	<i>5382</i>	<i>8.35</i>	<i>5528</i>	<i>9.11</i>						
3420	1800	<i>5021</i>	<i>6.25</i>	<i>5204</i>	<i>7.11</i>	<i>5375</i>	<i>7.96</i>	<i>5531</i>	<i>8.79</i>										
3820	2000	<i>5354</i>	<i>7.34</i>	<i>5526</i>	<i>8.25</i>														
4180	2200																		

Performance shown is for installation type B: Free inlet, ducted outlet. Power rating (BHP) does not include drive losses. Performance ratings do not include the effects of appurtenances in the airstream.

Size 14 CBD Belt Driven Centaxial

Wheel Diameter: 13.98"
 Tip Speed, FPM = 3.66 x Fan RPM
 Max. BHP = 0.100 x (RPM ÷ 1000)³

Inlet Diameter: 20.88"
 Inlet Area: 2.37 ft.²
 Outlet Area: 2.37 ft.²

LEGEND
 Class I fans = regular face (Max. 3006 RPM)
 Class II fans = **bold face** (Max. 3909 RPM)
 Class III fans = *italic face* (Max. 4962 RPM)
Underlined figures indicate maximum static efficiency.

CFM	OV	0.5" SP		1" SP		1.5" SP		2" SP		2.5" SP		3" SP		3.5" SP		4" SP		5" SP	
		RPM	BHP	RPM	BHP	RPM	BHP	RPM	BHP	RPM	BHP	RPM	BHP	RPM	BHP	RPM	BHP	RPM	BHP
948	400	1109	0.13	1362	0.25	1596	0.39												
1185	500	1242	0.18	1481	0.32	1679	0.47	1867	0.64	2053	0.82								
1422	600	1378	0.23	1615	0.40	1799	0.58	1965	0.76	2121	0.95	2277	1.16	2432	1.38				
1659	700	1529	0.30	1748	0.49	1930	0.70	2086	0.90	2231	1.11	2367	1.33	2500	1.56	2635	1.80		
1896	800	1688	0.39	1881	0.59	2065	0.83	2218	1.06	2354	1.29	2485	1.53	2607	1.77	2724	2.02	2958	2.56
2133	900	1851	0.50	2025	0.71	2197	0.97	2353	1.23	2487	1.49	2610	1.75	2727	2.01	2840	2.29	3052	2.85
2370	1000	2016	0.63	2178	0.86	2332	1.12	2485	1.42	2622	1.71	2743	1.99	2855	2.28	2963	2.57	3168	3.18
2607	1100	2184	0.78	2337	1.04	2476	1.31	2617	1.61	2755	1.94	2879	2.26	2990	2.57	3094	2.89	3290	3.53
2844	1200	2353	0.96	2499	1.24	2629	1.53	2757	1.83	2886	2.17	3011	2.53	3125	2.88	3229	3.23	3419	3.91
3081	1300	2524	1.16	2663	1.48	2787	1.78	2905	2.10	3023	2.44	3142	2.81	3257	3.20	3364	3.59	3554	4.33
3318	1400	2696	1.39	2828	1.73	2947	2.07	3058	2.40	3167	2.74	3278	3.13	3389	3.53	3496	3.95	3689	4.77
3555	1500	2869	1.66	2995	2.03	3110	2.39	3216	2.74	3318	3.10	3420	3.48	3524	3.89	3627	4.33	3823	5.22
3792	1600	3043	1.96	3163	2.35	3274	2.74	3377	3.12	3474	3.49	3569	3.88	3665	4.30	3762	4.74	<i>3954</i>	<i>5.68</i>
4266	1800	3394	2.67	3503	3.11	3606	3.55	3703	3.99	3793	4.41	3880	4.83	<i>3965</i>	<i>5.26</i>	<i>4050</i>	<i>5.71</i>	<i>4221</i>	<i>6.68</i>
4740	2000	3747	3.55	3847	4.04	<i>3942</i>	<i>4.53</i>	<i>4033</i>	<i>5.02</i>	<i>4119</i>	<i>5.50</i>	<i>4201</i>	<i>5.97</i>	<i>4280</i>	<i>6.44</i>	<i>4357</i>	<i>6.91</i>	<i>4509</i>	<i>7.90</i>
5214	2200	<i>4102</i>	<i>4.61</i>	<i>4194</i>	<i>5.15</i>	<i>4282</i>	<i>5.69</i>	<i>4367</i>	<i>6.23</i>	<i>4449</i>	<i>6.77</i>	<i>4527</i>	<i>7.29</i>	<i>4602</i>	<i>7.81</i>	<i>4674</i>	<i>8.33</i>	<i>4815</i>	<i>9.37</i>

CFM	OV	6" SP		7" SP		8" SP		9" SP		10" SP		11" SP		12" SP		13" SP		14" SP	
		RPM	BHP	RPM	BHP	RPM	BHP	RPM	BHP	RPM	BHP	RPM	BHP	RPM	BHP	RPM	BHP	RPM	BHP
1896	800	3192	3.13																
2133	900	3259	3.44	3468	4.07	3674	4.73												
2370	1000	3359	3.80	3545	4.45	3733	5.13	<i>3920</i>	<i>5.85</i>	<i>4105</i>	<i>6.58</i>								
2607	1100	3476	4.19	3650	4.87	3820	5.58	<i>3990</i>	<i>6.32</i>	<i>4161</i>	<i>7.08</i>	<i>4331</i>	<i>7.87</i>	<i>4499</i>	<i>8.68</i>				
2844	1200	3598	4.62	3769	5.34	<i>3930</i>	<i>6.08</i>	<i>4086</i>	<i>6.83</i>	<i>4242</i>	<i>7.62</i>	<i>4398</i>	<i>8.44</i>	<i>4555</i>	<i>9.28</i>	<i>4710</i>	<i>10.14</i>	<i>4865</i>	<i>11.02</i>
3081	1300	3726	5.07	3891	5.84	<i>4050</i>	<i>6.62</i>	<i>4200</i>	<i>7.41</i>	<i>4346</i>	<i>8.23</i>	<i>4490</i>	<i>9.06</i>	<i>4633</i>	<i>9.92</i>	<i>4778</i>	<i>10.81</i>	<i>4922</i>	<i>11.72</i>
3318	1400	3860	5.57	<i>4019</i>	<i>6.37</i>	<i>4172</i>	<i>7.19</i>	<i>4321</i>	<i>8.03</i>	<i>4463</i>	<i>8.89</i>	<i>4600</i>	<i>9.75</i>	<i>4734</i>	<i>10.63</i>	<i>4867</i>	<i>11.53</i>		
3555	1500	<i>3996</i>	<i>6.09</i>	<i>4153</i>	<i>6.94</i>	<i>4301</i>	<i>7.80</i>	<i>4444</i>	<i>8.68</i>	<i>4584</i>	<i>9.58</i>	<i>4719</i>	<i>10.49</i>	<i>4849</i>	<i>11.41</i>				
3792	1600	<i>4131</i>	<i>6.63</i>	<i>4289</i>	<i>7.55</i>	<i>4435</i>	<i>8.46</i>	<i>4574</i>	<i>9.38</i>	<i>4709</i>	<i>10.31</i>	<i>4841</i>	<i>11.26</i>						
4266	1800	<i>4393</i>	<i>7.73</i>	<i>4556</i>	<i>8.81</i>	<i>4706</i>	<i>9.86</i>	<i>4844</i>	<i>10.89</i>										
4740	2000	<i>4663</i>	<i>8.97</i>	<i>4819</i>	<i>10.13</i>														
5214	2200	<i>4953</i>	<i>10.46</i>																

Size 16 CBD Belt Driven Centaxial

Wheel Diameter: 15.75"
 Tip Speed, FPM = 4.12 x Fan RPM
 Max. BHP = 0.182 x (RPM ÷ 1000)³

Inlet Diameter: 23.63"
 Inlet Area: 3.04 ft.²
 Outlet Area: 3.04 ft.²

LEGEND
 Class I fans = regular face (Max. 2668 RPM)
 Class II fans = **bold face** (Max. 3468 RPM)
 Class III fans = *italic face* (Max. 4402 RPM)
Underlined figures indicate maximum static efficiency.

CFM	OV	0.5" SP		1" SP		1.5" SP		2" SP		2.5" SP		3" SP		3.5" SP		4" SP		5" SP	
		RPM	BHP	RPM	BHP	RPM	BHP	RPM	BHP	RPM	BHP	RPM	BHP	RPM	BHP	RPM	BHP	RPM	BHP
1216	400	989	0.17	1213	0.32	1419	0.50												
1520	500	1109	0.23	1321	0.41	1496	0.61	1660	0.82	1824	1.05								
1824	600	1232	0.30	1441	0.52	1604	0.74	1751	0.98	1888	1.22	2025	1.48	2162	1.76				
2128	700	1368	0.39	1560	0.64	1722	0.90	1860	1.15	1989	1.43	2108	1.70	2225	2.00	2343	2.30	2577	2.96
2432	800	1511	0.51	1680	0.76	1843	1.07	1978	1.36	2099	1.66	2215	1.96	2323	2.28	2426	2.60	2632	3.28
2736	900	1657	0.65	1810	0.92	1961	1.25	2100	1.59	2219	1.92	2327	2.25	2431	2.59	2531	2.94	2718	3.65
3040	1000	1805	0.81	1948	1.12	2083	1.45	2218	1.82	2340	2.20	2448	2.57	2547	2.93	2642	3.31	2823	4.08
3344	1100	1956	1.01	2091	1.35	2214	1.69	2337	2.07	2459	2.49	2569	2.91	2668	3.31	2760	3.71	2933	4.53
3648	1200	2108	1.24	2237	1.62	2351	1.98	2463	2.37	2577	2.80	2687	3.26	2789	3.71	2882	4.15	3050	5.03
3952	1300	2261	1.51	2384	1.92	2493	2.31	2597	2.71	2700	3.14	2806	3.63	2907	4.12	3002	4.61	3171	5.57
4256	1400	2415	1.81	2532	2.25	2637	2.68	2735	3.10	2831	3.55	2928	4.03	3025	4.55	3120	5.08	3293	6.14
4560	1500	2571	2.16	2682	2.63	2784	3.10	2877	3.55	2967	4.01	3056	4.49	3147	5.02	3238	5.57	3412	6.72
4864	1600	2727	2.55	2833	3.06	2931	3.56	3021	4.04	3107	4.52	3191	5.02	3275	5.55	3360	6.11	<i>3529</i>	<i>7.31</i>
5472	1800	3042	3.48	3138	4.05	3229	4.62	3314	5.18	3394	5.72	<i>3471</i>	<i>6.26</i>	<i>3546</i>	<i>6.82</i>	<i>3620</i>	<i>7.38</i>	<i>3770</i>	<i>8.61</i>
6080	2000	3359	4.63	3447	5.26	<i>3531</i>	<i>5.89</i>	<i>3611</i>	<i>6.52</i>	<i>3687</i>	<i>7.14</i>	<i>3759</i>	<i>7.74</i>	<i>3829</i>	<i>8.35</i>	<i>3897</i>	<i>8.95</i>	<i>4030</i>	<i>10.21</i>
6688	2200	<i>3678</i>	<i>6.02</i>	<i>3759</i>	<i>6.72</i>	<i>3837</i>	<i>7.41</i>	<i>3911</i>	<i>8.10</i>	<i>3983</i>	<i>8.79</i>	<i>4052</i>	<i>9.47</i>	<i>4118</i>	<i>10.13</i>	<i>4182</i>	<i>10.80</i>	<i>4306</i>	<i>12.13</i>

CFM	OV	6" SP		7" SP		8" SP		9" SP		10" SP		11" SP		12" SP		13" SP		14" SP	
		RPM	BHP	RPM	BHP	RPM	BHP	RPM	BHP	RPM	BHP	RPM	BHP	RPM	BHP	RPM	BHP	RPM	BHP
2432	800	2837	4.01																
2736	900	2900	4.41	3084	5.22	3265	6.05												
3040	1000	2992	4.87	3156	5.70	3321	6.58	<i>3485</i>	<i>7.48</i>	<i>3648</i>									

Size 18 CBD Belt Driven Centaxial

Wheel Diameter: 17.72"

Tip Speed, FPM = 4.64 x Fan RPM

Max. BHP = 0.335 x (RPM ÷ 1000)³

Inlet Diameter: 26.38"

Inlet Area: 3.79 ft.²

Outlet Area: 3.79 ft.²

LEGEND	
Class I fans = regular face	(Max. 2371 RPM)
Class II fans = bold face	(Max. 3082 RPM)
Class III fans = <i>italic face</i>	(Max. 3913 RPM)
<u>Underlined</u> figures indicate maximum static efficiency.	

CFM	OV	0.5" SP		1" SP		1.5" SP		2" SP		2.5" SP		3" SP		3.5" SP		4" SP		5" SP	
		RPM	BHP	RPM	BHP	RPM	BHP	RPM	BHP	RPM	BHP	RPM	BHP	RPM	BHP	RPM	BHP	RPM	BHP
1516	400	819	0.18	1022	0.35														
1895	500	916	0.24	1099	0.44	1259	0.66												
2274	600	1019	0.32	1191	0.55	1335	0.80	1469	1.05	1598	1.32								
2653	700	1127	0.41	1288	0.68	1426	0.96	1548	1.24	1664	1.54	1775	1.84	1886	2.16				
3032	800	1242	0.53	1390	0.82	1522	1.14	1639	1.45	1746	1.78	1849	2.12	1948	2.46	2045	2.81		
3411	900	1362	0.67	1496	0.99	1620	1.33	1734	1.69	1838	2.05	1933	2.41	2026	2.79	2116	3.17	2290	3.95
3790	1000	1487	0.85	1605	1.18	1723	1.55	1832	1.94	1933	2.34	2026	2.74	2114	3.15	2197	3.55	2361	4.40
4169	1100	1614	1.06	1719	1.41	1830	1.81	1933	2.23	2030	2.65	2122	3.09	2208	3.53	2288	3.97	2441	4.88
4548	1200	1743	1.32	1838	1.68	1938	2.09	2038	2.54	2130	3.00	2219	3.47	2303	3.95	2383	4.43	2531	5.40
4927	1300	1873	1.61	1960	1.99	2051	2.42	2145	2.89	2234	3.38	2319	3.88	2400	4.39	2478	4.90	2625	5.95
5306	1400	2004	1.94	2085	2.35	2168	2.79	2254	3.28	2341	3.81	2422	4.33	2501	4.87	2576	5.42	2720	6.53
5685	1500	2136	2.33	2211	2.76	2288	3.22	2367	3.72	2448	4.26	2528	4.83	2604	5.39	2677	5.97	2816	7.15
6064	1600	2269	2.77	2339	3.22	2411	3.70	2483	4.21	2559	4.77	2635	5.36	2709	5.96	2780	6.57	2915	7.80
6822	1800	2536	3.81	2598	4.31	2661	4.83	2725	5.38	2790	5.96	2857	6.58	2925	7.24	2992	7.91	<i>3120</i>	<i>9.27</i>
7580	2000	2805	5.10	2861	5.65	2917	6.21	2974	6.80	3031	7.42	<i>3089</i>	<i>8.06</i>	<i>3149</i>	<i>8.74</i>	<i>3210</i>	<i>9.45</i>	<i>3332</i>	<i>10.94</i>
8338	2200	3075	6.67	<i>3125</i>	<i>7.26</i>	<i>3176</i>	<i>7.87</i>	<i>3228</i>	<i>8.51</i>	<i>3280</i>	<i>9.16</i>	<i>3332</i>	<i>9.84</i>	<i>3385</i>	<i>10.55</i>	<i>3439</i>	<i>11.28</i>	<i>3549</i>	<i>12.84</i>

CFM	OV	6" SP		7" SP		8" SP		9" SP		10" SP		11" SP		12" SP		13" SP		14" SP	
		RPM	BHP	RPM	BHP	RPM	BHP	RPM	BHP	RPM	BHP	RPM	BHP	RPM	BHP	RPM	BHP	RPM	BHP
3032	800																		
3411	900																		
3790	1000	2517	5.26	2672	6.16														
4169	1100	2590	5.81	2733	6.75	2873	7.73												
4548	1200	2670	6.38	2807	7.40	2938	8.42	3067	9.47	<i>3196</i>	<i>10.56</i>								
4927	1300	2759	7.00	2887	8.07	3014	9.17	<i>3137</i>	<i>10.28</i>	<i>3256</i>	<i>11.39</i>	<i>3375</i>	<i>12.55</i>	<i>3495</i>	<i>13.76</i>				
5306	1400	2852	7.65	2976	8.79	3095	9.93	<i>3213</i>	<i>11.12</i>	<i>3329</i>	<i>12.32</i>	<i>3440</i>	<i>13.50</i>	<i>3551</i>	<i>14.73</i>	<i>3661</i>	<i>15.98</i>	<i>3773</i>	<i>17.30</i>
5685	1500	2947	8.35	3069	9.55	3184	10.76	<i>3296</i>	<i>11.99</i>	<i>3407</i>	<i>13.26</i>	<i>3515</i>	<i>14.53</i>	<i>3621</i>	<i>15.81</i>	<i>3725</i>	<i>17.10</i>	<i>3827</i>	<i>18.40</i>
6064	1600	3043	9.07	<i>3164</i>	<i>10.35</i>	<i>3278</i>	<i>11.64</i>	<i>3386</i>	<i>12.93</i>	<i>3491</i>	<i>14.24</i>	<i>3595</i>	<i>15.58</i>	<i>3698</i>	<i>16.94</i>	<i>3798</i>	<i>18.29</i>	<i>3896</i>	<i>19.65</i>
6822	1800	<i>3241</i>	<i>10.65</i>	<i>3357</i>	<i>12.07</i>	<i>3468</i>	<i>13.50</i>	<i>3574</i>	<i>14.94</i>	<i>3675</i>	<i>16.38</i>	<i>3772</i>	<i>17.84</i>	<i>3866</i>	<i>19.30</i>				
7580	2000	<i>3447</i>	<i>12.45</i>	<i>3557</i>	<i>13.98</i>	<i>3663</i>	<i>15.53</i>	<i>3766</i>	<i>17.12</i>	<i>3865</i>	<i>18.71</i>								
8338	2200	<i>3659</i>	<i>14.47</i>	<i>3765</i>	<i>16.13</i>	<i>3866</i>	<i>17.80</i>												

Size 20 CBD Belt Driven Centaxial

Wheel Diameter: 19.68"

Tip Speed, FPM = 5.15 x Fan RPM

Max. BHP = 0.571 x (RPM ÷ 1000)³

Inlet Diameter: 29.53"

Inlet Area: 4.76 ft.²

Outlet Area: 4.76 ft.²

LEGEND	
Class I fans = regular face	(Max. 2135 RPM)
Class II fans = bold face	(Max. 2775 RPM)
Class III fans = <i>italic face</i>	(Max. 3522 RPM)
<u>Underlined</u> figures indicate maximum static efficiency.	

CFM	OV	0.5" SP		1" SP		1.5" SP		2" SP		2.5" SP		3" SP		3.5" SP		4" SP		5" SP	
		RPM	BHP	RPM	BHP	RPM	BHP	RPM	BHP	RPM	BHP	RPM	BHP	RPM	BHP	RPM	BHP	RPM	BHP
1896	400	740	0.23	921	0.44														
2370	500	828	0.30	992	0.56	1135	0.82												
2844	600	922	0.40	1076	0.69	1205	1.00	1325	1.32	1439	1.65								
3318	700	1021	0.52	1164	0.85	1288	1.20	1397	1.56	1501	1.93	1600	2.30	1699	2.70				
3792	800	1125	0.67	1257	1.03	1375	1.42	1480	1.82	1576	2.23	1668	2.65	1757	3.08	1843	3.51		
4266	900	1235	0.85	1354	1.24	1465	1.67	1567	2.12	1660	2.57	1745	3.02	1828	3.49	1909	3.97	2064	4.93
4740	1000	1349	1.08	1453	1.49	1559	1.96	1656	2.44	1746	2.93	1830	3.43	1909	3.94	1984	4.45	2130	5.51
5214	1100	1464	1.35	1558	1.78	1656	2.28	1748	2.80	1835	3.33	1917	3.88	1994	4.43	2067	4.99	2203	6.10
5688	1200	1581	1.67	1666	2.12	1755	2.64	1844	3.20	1927	3.77	2006	4.36	2081	4.95	2153	5.55	2285	6.76
6162	1300	1700	2.04	1777	2.52	1858	3.06	1941	3.64	2022	4.26	2097	4.88	2170	5.51	2240	6.16	2371	7.46
6636	1400	1819	2.47	1891	2.98	1964	3.53	2041	4.14	2118	4.79	2191	5.45	2261	6.12	2329	6.80	2457	8.19
7110	1500	1939	2.97	2006	3.50	2074	4.07	2144	4.70	2216	5.37	2288	6.08	2355	6.78	2420	7.49	2545	8.97
7584	1600	2060	3.52	2122	4.08	2186	4.69	2250	5.32	2317	6.01	2385	6.75	2451	7.50	2515	8.26	2635	9.80
8532	1800	2302	4.85	2358	5.48	2414	6.13	2470	6.81	2528	7.53	2587	8.30	2648	9.12	2708	9.96	<i>2822</i>	<i>11.65</i>
9480	2000	2547	6.50	2596	7.18	2647	7.89	2697	8.62	2748	9.39	<i>2800</i>	<i>10.19</i>	<i>2853</i>	<i>11.04</i>	<i>2907</i>	<i>11.92</i>	<i>3015</i>	<i>13.77</i>
10428	2200	<i>2792</i>	<i>8.50</i>	<i>2837</i>	<i>9.24</i>	<i>2882</i>	<i>10.00</i>	<i>2928</i>	<i>10.79</i>	<i>2974</i>	<i>11.61</i>	<i>3021</i>	<i>12.46</i>	<i>3067</i>	<i>13.33</i>	<i>3115</i>	<i>14.24</i>	<i>3213</i>	<i>16.18</i>

CFM	OV	6" SP		7" SP		8" SP		9" SP		10" SP		11" SP		12" SP		13" SP		14" SP	
		RPM	BHP	RPM	BHP	RPM	BHP	RPM	BHP	RPM	BHP	RPM	BHP	RPM	BHP	RPM	BHP	RPM	BHP
3792	800																		
4266	900																		
4740	1000	2269	6.57	2407	7.70														
5214	1100	2336	<																

Size 22 CBD Belt Driven Centaxial

Wheel Diameter: 22.05"

Tip Speed, FPM = 5.77 x Fan RPM

Max. BHP = 1.011 x (RPM ÷ 1000)³

Inlet Diameter: 33.47"

Inlet Area: 6.11 ft.²

Outlet Area: 6.11 ft.²

LEGEND		
Class I fans = regular face	(Max. 1906 RPM)	
Class II fans = bold face	(Max. 2477 RPM)	
Class III fans = <i>italic face</i>	(Max. 3144 RPM)	
<u>Underlined</u> figures indicate maximum static efficiency.		

CFM	OV	0.5" SP		1" SP		1.5" SP		2" SP		2.5" SP		3" SP		3.5" SP		4" SP		5" SP	
		RPM	BHP	RPM	BHP	RPM	BHP	RPM	BHP	RPM	BHP	RPM	BHP	RPM	BHP	RPM	BHP	RPM	BHP
2444	400	668	0.30	828	0.57														
3055	500	749	0.40	894	0.72	1020	1.06												
3666	600	836	0.52	972	0.90	1086	1.29	1191	1.70	1291	2.12								
4277	700	927	0.68	1053	1.11	1163	1.56	1259	2.01	1351	2.49	1438	2.97	1523	3.47				
4888	800	1024	0.88	1139	1.35	1243	1.85	1337	2.37	1421	2.89	1501	3.42	1580	3.97	1655	4.52		
5499	900	1125	1.13	1228	1.63	1326	2.18	1416	2.75	1499	3.33	1574	3.91	1647	4.51	1718	5.13	1854	6.36
6110	1000	1230	1.44	1320	1.96	1413	2.56	1498	3.17	1578	3.81	1653	4.46	1722	5.10	1788	5.76	1916	7.11
6721	1100	1336	1.80	1417	2.35	1502	2.99	1584	3.66	1660	4.34	1733	5.04	1801	5.75	1865	6.46	1986	7.90
7332	1200	1443	2.23	1517	2.82	1594	3.47	1672	4.19	1745	4.92	1814	5.67	1881	6.44	1944	7.20	2062	8.76
7943	1300	1552	2.74	1620	3.36	1689	4.03	1761	4.78	1832	5.57	1899	6.36	1963	7.18	2025	8.01	2141	9.68
8554	1400	1661	3.32	1724	3.97	1787	4.67	1854	5.45	1921	6.27	1986	7.13	2047	7.98	2107	8.86	2220	10.64
9165	1500	1772	3.99	1830	4.68	1889	5.41	1949	6.19	2012	7.05	2074	7.95	2134	8.86	2192	9.79	2302	11.68
9776	1600	1882	4.74	1937	5.47	1992	6.23	2047	7.04	2105	7.92	2164	8.85	2223	9.83	2279	10.80	2385	12.77
10998	1800	2105	6.55	2153	7.34	2201	8.17	2251	9.06	2300	9.97	2351	10.94	2404	11.98	2456	13.04	2557	15.23
12220	2000	2328	8.77	2372	9.65	2415	10.55	2459	11.50	2503	12.47	2548	13.49	2594	14.57	2641	15.69	2735	18.05
13442	2200	2553	11.48	2592	12.43	2632	13.42	2672	14.44	2711	15.47	2752	16.56	2792	17.66	2833	18.81	2918	21.27

CFM	OV	6" SP		7" SP		8" SP		9" SP		10" SP		11" SP		12" SP		13" SP		14" SP	
		RPM	BHP	RPM	BHP	RPM	BHP	RPM	BHP	RPM	BHP	RPM	BHP	RPM	BHP	RPM	BHP	RPM	BHP
4888	800																		
5499	900	1987	7.66																
6110	1000	2039	8.48	2159	9.91														
6721	1100	2102	9.39	2215	10.90	2323	12.43	2432	14.04										
7332	1200	2172	10.34	2278	11.95	2382	13.60	2483	15.26	2582	16.96	2683	18.78						
7943	1300	2248	11.36	2349	13.08	2447	14.82	2544	16.60	2638	18.39	2730	20.20	2822	22.08	2915	24.05		
8554	1400	2326	12.45	2425	14.27	2518	16.10	2610	17.98	2701	19.90	2789	21.81	2875	23.74	2961	25.73	3046	27.75
9165	1500	2406	13.60	2503	15.53	2595	17.48	2682	19.43	2768	21.44	2853	23.48	2937	25.54	3019	27.61	3099	29.69
9776	1600	2486	14.80	2582	16.85	2673	18.92	2759	21.00	2842	23.10	2922	25.20	3002	27.36	3082	29.57		
10998	1800	2652	17.43	2744	19.71	2832	22.01	2917	24.34	2997	26.64	3074	28.97						
12220	2000	2826	20.47	2913	22.92	2997	25.42	3078	27.95										
13442	2200	3004	23.88	3088	26.56														

Size 25 CBD Belt Driven Centaxial

Wheel Diameter: 24.80"

Tip Speed, FPM = 6.49 x Fan RPM

Max. BHP = 1.82 x (RPM ÷ 1000)³

Inlet Diameter: 37.41"

Inlet Area: 7.63 ft.²

Outlet Area: 7.63 ft.²

LEGEND		
Class I fans = regular face	(Max. 1663 RPM)	
Class II fans = bold face	(Max. 2202 RPM)	
Class III fans = <i>italic face</i>	(Max. 2795 RPM)	
<u>Underlined</u> figures indicate maximum static efficiency.		

CFM	OV	0.5" SP		1" SP		1.5" SP		2" SP		2.5" SP		3" SP		3.5" SP		4" SP		5" SP	
		RPM	BHP	RPM	BHP	RPM	BHP	RPM	BHP	RPM	BHP	RPM	BHP	RPM	BHP	RPM	BHP	RPM	BHP
3052	400	591	0.37	734	0.71														
3815	500	662	0.49	791	0.90	904	1.32												
4578	600	738	0.65	860	1.12	961	1.61	1056	2.12	1145	2.65								
5341	700	818	0.84	931	1.38	1029	1.94	1115	2.51	1197	3.11	1274	3.70	1351	4.33				
6104	800	902	1.09	1006	1.67	1099	2.30	1182	2.94	1257	3.59	1330	4.27	1400	4.95	1468	5.65		
6867	900	991	1.39	1084	2.02	1172	2.71	1252	3.42	1326	4.15	1393	4.88	1458	5.63	1522	6.40	1643	7.93
7630	1000	1083	1.77	1164	2.42	1248	3.18	1324	3.95	1395	4.74	1462	5.55	1524	6.36	1583	7.18	1698	8.88
8393	1100	1176	2.22	1249	2.91	1326	3.70	1399	4.54	1467	5.39	1532	6.27	1593	7.16	1650	8.04	1758	9.85
9156	1200	1270	2.74	1336	3.47	1406	4.30	1476	5.20	1541	6.11	1603	7.04	1663	8.01	1720	8.98	1824	10.90
9919	1300	1365	3.35	1426	4.12	1489	4.98	1554	5.92	1618	6.91	1677	7.89	1735	8.92	1790	9.96	1894	12.06
10682	1400	1462	4.07	1518	4.88	1575	5.76	1635	6.73	1696	7.78	1754	8.85	1808	9.90	1862	11.01	1963	13.24
11445	1500	1558	4.88	1611	5.74	1664	6.66	1718	7.65	1775	8.73	1831	9.86	1885	11.00	1936	12.15	2034	14.50
12208	1600	1655	5.80	1704	6.70	1754	7.67	1804	8.68	1857	9.80	1910	10.97	1962	12.17	2012	13.39	2107	15.86
13734	1800	1851	8.00	1894	9.00	1938	10.04	1982	11.14	2027	12.29	2073	13.52	2121	14.83	2168	16.17	2258	18.89
15260	2000	2047	10.72	2086	11.81	2126	12.96	2165	14.13	2205	15.36	2245	16.63	2287	17.99	2329	19.40	2414	22.37
16786	2200	2245	14.03	2280	15.22	2316	16.45	2351	17.71	2387	19.01	2424	20.38	2460	21.77	2497	23.21	2574	26.32

CFM	OV	6" SP		7" SP		8" SP		9" SP		10" SP		11" SP		12" SP		13" SP		14" SP	
		RPM	BHP	RPM	BHP	RPM	BHP	RPM	BHP	RPM	BHP	RPM	BHP	RPM	BHP	RPM	BHP	RPM	BHP
6104	800																		
6867	900																		
7630	1000	1808	10.60	1915	12.38														
8393	1100	1862	11.71	1963	13.60	2061													

Size 28 CBD Belt Driven Centaxial

Wheel Diameter: 27.95"
 Tip Speed, FPM = 7.32 x Fan RPM
 Max. BHP = 3.40 x (RPM ÷ 1000)³

Inlet Diameter: 41.72"
 Inlet Area: 9.50 ft.²
 Outlet Area: 9.50 ft.²

LEGEND
 Class I fans = regular face (Max. 1476 RPM)
 Class II fans = **bold face** (Max. 1919 RPM)
 Class III fans = *italic face* (Max. 2435 RPM)
Underlined figures indicate maximum static efficiency.

CFM	OV	0.5" SP		1" SP		1.5" SP		2" SP		2.5" SP		3" SP		3.5" SP		4" SP		5" SP	
		RPM	BHP	RPM	BHP	RPM	BHP	RPM	BHP	RPM	BHP	RPM	BHP	RPM	BHP	RPM	BHP	RPM	BHP
3800	400	505	0.43	638	0.85														
4750	500	565	0.57	679	1.06	784	1.58												
5700	600	627	0.74	735	1.32	825	1.91	913	2.53										
6650	700	693	0.96	795	1.60	879	2.27	956	2.97	1032	3.69	1107	4.44						
7600	800	760	1.21	856	1.93	939	2.69	1010	3.46	1078	4.26	1145	5.07	1210	5.90	1277	6.79		
8550	900	830	1.52	920	2.30	999	3.14	1070	4.00	1133	4.87	1193	5.76	1253	6.68	1312	7.60	1429	9.54
9500	1000	902	1.89	986	2.75	1062	3.65	1130	4.59	1192	5.54	1249	6.51	1303	7.49	1358	8.51	1464	10.55
10450	1100	976	2.33	1053	3.25	1126	4.23	1192	5.24	1252	6.27	1309	7.33	1361	8.39	1411	9.47	1509	11.68
11400	1200	1051	2.83	1122	3.83	1191	4.87	1255	5.96	1314	7.08	1369	8.21	1421	9.36	1469	10.50	1560	12.84
12350	1300	1127	3.42	1193	4.49	1258	5.60	1320	6.76	1376	7.93	1430	9.15	1481	10.39	1529	11.62	1618	14.13
13300	1400	1203	4.09	1265	5.23	1326	6.42	1385	7.63	1440	8.88	1492	10.16	1542	11.48	1589	12.80	1678	15.50
14250	1500	1281	4.85	1339	6.08	1396	7.33	1452	8.62	1506	9.94	1556	11.28	1604	12.66	1651	14.08	1738	16.94
15200	1600	1359	5.72	1413	7.01	1467	8.34	1520	9.70	1572	11.09	1621	12.50	1668	13.95	1713	15.43	1798	18.44
17100	1800	1515	7.75	1564	9.19	1612	10.67	1660	12.19	1707	13.71	1753	15.26	1798	16.84	1841	18.46	1922	21.75
19000	2000	1673	10.26	1717	11.85	1761	13.48	1804	15.13	1847	16.82	1889	18.50	1931	20.22	1972	21.97	2050	25.53
20900	2200	1832	13.30	1872	15.03	1912	16.81	1952	18.62	1991	20.45	2030	22.30	2068	24.14	2107	26.05	2181	29.86

CFM	OV	6" SP		7" SP		8" SP		9" SP		10" SP		11" SP		12" SP		13" SP		14" SP	
		RPM	BHP	RPM	BHP	RPM	BHP	RPM	BHP	RPM	BHP	RPM	BHP	RPM	BHP	RPM	BHP	RPM	BHP
7600	800																		
8550	900																		
9500	1000	1569	12.68																
10450	1100	1605	13.91	1701	16.26														
11400	1200	1651	15.29	1739	17.73	1826	20.23	1915	22.90										
12350	1300	1701	16.67	1785	19.33	1867	21.98	1947	24.65	2028	27.45	2111	30.44						
13300	1400	1758	18.19	1835	20.93	1913	23.79	1989	26.63	2064	29.51	2139	32.47	2215	35.57				
14250	1500	1817	19.78	1892	22.70	1964	25.66	2036	28.69	2108	31.76	2178	34.81	2248	37.94	2318	41.15	2389	44.50
15200	1600	1878	21.50	1951	24.56	2020	27.64	2088	30.81	2156	34.06	2223	37.29	2290	40.59	2355	43.85	2420	47.18
17100	1800	1999	25.15	2071	28.55	2140	32.02	2204	35.47	2265	38.93	2326	42.50	2386	46.10				
19000	2000	2123	29.18	2193	32.93	2260	36.73	2324	40.55	2385	44.39								
20900	2200	2252	33.80	2319	37.82	2383	41.89												

Size 32 CBD Belt Driven Centaxial

Wheel Diameter: 31.50"
 Tip Speed, FPM = 8.25 x Fan RPM
 Max. BHP = 6.19 x (RPM ÷ 1000)³

Inlet Diameter: 46.47"
 Inlet Area: 11.78 ft.²
 Outlet Area: 11.78 ft.²

LEGEND
 Class I fans = regular face (Max. 1310 RPM)
 Class II fans = **bold face** (Max. 1671 RPM)
 Class III fans = *italic face* (Max. 2160 RPM)
Underlined figures indicate maximum static efficiency.

CFM	OV	0.5" SP		1" SP		1.5" SP		2" SP		2.5" SP		3" SP		3.5" SP		4" SP		5" SP	
		RPM	BHP	RPM	BHP	RPM	BHP	RPM	BHP	RPM	BHP	RPM	BHP	RPM	BHP	RPM	BHP	RPM	BHP
4712	400	443	0.53																
5890	500	495	0.71	597	1.32	693	1.97												
7068	600	548	0.91	644	1.62	726	2.36	806	3.15										
8246	700	604	1.16	696	1.97	771	2.81	841	3.68	909	4.57	979	5.54						
9424	800	662	1.47	749	2.37	822	3.30	886	4.27	948	5.27	1008	6.28	1067	7.32				
10602	900	722	1.84	804	2.82	874	3.86	937	4.92	993	6.00	1048	7.12	1102	8.26	1155	9.40	1263	11.88
11780	1000	784	2.28	860	3.34	928	4.47	989	5.64	1044	6.82	1095	8.03	1144	9.25	1194	10.53	1290	13.08
12958	1100	848	2.80	918	3.95	983	5.16	1042	6.43	1096	7.71	1147	9.04	1193	10.34	1238	11.69	1327	14.44
14136	1200	912	3.40	977	4.64	1040	5.95	1096	7.28	1149	8.68	1199	10.11	1245	11.53	1288	12.96	1370	15.88
15314	1300	978	4.10	1038	5.43	1097	6.82	1152	8.25	1203	9.72	1251	11.24	1297	12.79	1339	14.30	1418	17.41
16492	1400	1044	4.89	1100	6.32	1156	7.80	1209	9.32	1258	10.86	1305	12.48	1349	14.10	1391	15.74	1470	19.09
17670	1500	1111	5.80	1163	7.31	1215	8.87	1266	10.48	1314	12.12	1359	13.79	1403	15.55	1444	17.29	1522	20.84
18848	1600	1178	6.82	1228	8.44	1276	10.08	1325	11.79	1371	13.50	1415	15.26	1457	17.07	1498	18.94	1574	22.68
21204	1800	1313	9.23	1358	11.04	1401	12.86	1445	14.75	1487	16.63	1529	18.57	1569	20.54	1608	22.57	1680	26.66
23560	2000	1450	12.21	1490	14.19	1530	16.22	1569	18.28	1607	20.33	1646	22.46	1684	24.61	1721	26.79	1790	31.20
25916	2200	1587	15.80	1624	17.97	1660	20.17	1696	22.41	1731	24.67	1766	26.95	1802	29.31	1836	31.62	1903	36.40

CFM	OV	6" SP		7" SP		8" SP		9" SP		10" SP		11" SP		12" SP		13" SP		14" SP	
		RPM	BHP	RPM	BHP	RPM	BHP	RPM	BHP	RPM	BHP	RPM	BHP	RPM	BHP	RPM	BHP	RPM	BHP
9424	800																		
10602	900																		
11780	1000	1386	15.79																
12958	1100	1414	17.24	1501	20.18														
14136	1200	1452	18.92	1532	21.98	1611	25.12												
15314	1300	1494	20.62	1570	23.92	1643	27.18	1717	30.60	1791	34.16								
16492	1400	1542	22.46	1612	25.91	1682	29.43	1751	32.98	1819	36.59	1887	40.31	1957	44.28				
17670	1500	1593	24.42	1659	28.00	1725	31.74	17											

Size 35 CBD Belt Driven Centaxial

Wheel Diameter: 35.43"
 Tip Speed, FPM = 9.28 x Fan RPM
 Max. BHP = 12.12 x (RPM ÷ 1000)³

Inlet Diameter: 51.97"
 Inlet Area: 14.73 ft.²
 Outlet Area: 14.73 ft.²

LEGEND	
Class I fans = regular face	(Max. 1164 RPM)
Class II fans = bold face	(Max. 1486 RPM)
Class III fans = <i>italic face</i>	(Max. 1921 RPM)
<u>Underlined</u> figures indicate maximum static efficiency.	

CFM	OV	0.5" SP		1" SP		1.5" SP		2" SP		2.5" SP		3" SP		3.5" SP		4" SP		5" SP	
		RPM	BHP	RPM	BHP	RPM	BHP	RPM	BHP	RPM	BHP	RPM	BHP	RPM	BHP	RPM	BHP	RPM	BHP
5892	400	376	0.64																
7365	500	414	0.85	512	1.60														
8838	600	457	1.08	544	1.95	623	2.88												
10311	700	504	1.36	583	2.37	654	3.39	722	4.49	787	5.64								
11784	800	553	1.72	625	2.81	691	3.98	753	5.17	812	6.41	869	7.70						
13257	900	605	2.18	670	3.32	731	4.61	789	5.94	843	7.26	897	8.67	948	10.10	998	11.57		
14730	1000	657	2.70	717	3.92	774	5.30	828	6.76	879	8.21	929	9.72	977	11.24	1024	12.83	1115	16.10
16203	1100	709	3.30	767	4.64	820	6.08	870	7.65	918	9.25	965	10.87	1010	12.49	1054	14.15	1139	17.60
17676	1200	763	4.01	817	5.46	867	6.97	914	8.60	960	10.35	1004	12.10	1047	13.87	1088	15.61	1169	19.27
19149	1300	817	4.82	869	6.40	916	8.00	960	9.68	1004	11.53	1045	13.40	1086	15.31	1126	17.23	1202	21.05
20622	1400	871	5.73	921	7.45	966	9.16	1008	10.92	1049	12.80	1089	14.80	1127	16.82	1165	18.88	1238	22.96
22095	1500	926	6.78	974	8.64	1017	10.46	1057	12.30	1096	14.24	1134	16.31	1170	18.41	1206	20.59	1277	25.03
23568	1600	981	7.95	1027	9.94	1068	11.87	1107	13.84	1144	15.84	1180	17.94	1215	20.15	1250	22.47	1317	27.15
26514	1800	1092	10.73	1134	12.96	1173	15.18	1209	17.36	1243	19.55	1276	21.79	1308	24.09	1340	26.53	1402	31.63
29460	2000	1204	14.13	1243	16.62	1279	19.08	1313	21.53	1345	23.95	1376	26.40	1406	28.88	1435	31.40	1493	36.77
32406	2200	1316	18.21	1352	20.94	1386	23.67	1419	26.42	1449	29.08	1478	31.74	1506	34.41	1534	37.16	1587	42.70

CFM	OV	6" SP		7" SP		8" SP		9" SP		10" SP		11" SP		12" SP		13" SP		14" SP	
		RPM	BHP	RPM	BHP	RPM	BHP	RPM	BHP	RPM	BHP	RPM	BHP	RPM	BHP	RPM	BHP	RPM	BHP
11784	800																		
13257	900																		
14730	1000																		
16203	1100	1222	21.23																
17676	1200	1247	23.07	1322	26.96														
19149	1300	1276	25.03	1348	29.16	1418	33.40	<i>1488</i>	<i>37.85</i>										
20622	1400	1309	27.17	1377	31.45	1444	35.90	<i>1509</i>	<i>40.43</i>	<i>1574</i>	<i>45.15</i>								
22095	1500	1344	29.41	1409	33.87	1474	38.58	<i>1536</i>	<i>43.29</i>	<i>1596</i>	<i>48.03</i>	<i>1657</i>	<i>53.04</i>	<i>1718</i>	<i>58.23</i>				
23568	1600	1382	31.83	1444	36.49	<i>1506</i>	<i>41.36</i>	<i>1566</i>	<i>46.29</i>	<i>1624</i>	<i>51.27</i>	<i>1681</i>	<i>56.34</i>	<i>1738</i>	<i>61.59</i>	<i>1795</i>	<i>67.01</i>		
26514	1800	1462	36.90	<i>1520</i>	<i>42.13</i>	<i>1577</i>	<i>47.41</i>	<i>1633</i>	<i>52.78</i>	<i>1687</i>	<i>58.15</i>	<i>1741</i>	<i>63.72</i>	<i>1793</i>	<i>69.27</i>	<i>1845</i>	<i>75.00</i>	<i>1896</i>	<i>80.79</i>
29460	2000	<i>1548</i>	<i>42.37</i>	<i>1603</i>	<i>48.25</i>	<i>1656</i>	<i>54.11</i>	<i>1708</i>	<i>59.95</i>	<i>1759</i>	<i>65.83</i>	<i>1808</i>	<i>71.63</i>	<i>1858</i>	<i>77.72</i>	<i>1906</i>	<i>83.74</i>		
32406	2200	<i>1639</i>	<i>48.58</i>	<i>1690</i>	<i>54.77</i>	<i>1740</i>	<i>61.17</i>	<i>1789</i>	<i>67.64</i>	<i>1837</i>	<i>74.09</i>	<i>1884</i>	<i>80.51</i>						

Size 39 CBD Belt Driven Centaxial

Wheel Diameter: 39.37"
 Tip Speed, FPM = 10.31 x Fan RPM
 Max. BHP = 20.5 x (RPM ÷ 1000)³

Inlet Diameter: 59.06"
 Inlet Area: 19.02 ft.²
 Outlet Area: 19.02 ft.²

LEGEND	
Class I fans = regular face	(Max. 1028 RPM)
Class II fans = bold face	(Max. 1337 RPM)
Class III fans = <i>italic face</i>	(Max. 1696 RPM)
<u>Underlined</u> figures indicate maximum static efficiency.	

CFM	OV	0.5" SP		1" SP		1.5" SP		2" SP		2.5" SP		3" SP		3.5" SP		4" SP		5" SP	
		RPM	BHP	RPM	BHP	RPM	BHP	RPM	BHP	RPM	BHP	RPM	BHP	RPM	BHP	RPM	BHP	RPM	BHP
7608	400	344	0.84																
9510	500	381	1.11	467	2.08														
11412	600	423	1.42	499	2.55	568	3.73	633	4.98										
13314	700	467	1.81	536	3.09	599	4.42	658	5.80	714	7.24								
15216	800	515	2.33	577	3.69	634	5.18	689	6.72	741	8.31	790	9.92	839	11.63				
17118	900	563	2.93	620	4.38	673	6.02	724	7.74	772	9.45	818	11.20	863	13.03	907	14.91		
19020	1000	612	3.65	666	5.24	715	6.97	762	8.84	807	10.73	850	12.62	892	14.56	933	16.56	1012	20.68
20922	1100	662	4.49	713	6.23	759	8.05	803	10.04	845	12.11	886	14.19	925	16.25	964	18.40	1038	22.75
22824	1200	713	5.48	761	7.37	804	9.29	845	11.34	885	13.55	923	15.80	961	18.09	997	20.33	1068	24.99
24726	1300	764	6.61	810	8.67	850	10.69	889	12.83	927	15.14	963	17.53	999	20.01	1034	22.49	1101	27.42
26628	1400	815	7.88	859	10.12	898	12.30	935	14.55	970	16.89	1005	19.41	1039	22.04	1072	24.68	1136	29.97
28530	1500	867	9.35	909	11.75	947	14.12	981	16.43	1015	18.89	1048	21.47	1081	24.23	1112	27.00	1173	32.65
30432	1600	919	10.99	959	13.55	995	16.05	1029	18.57	1061	21.11	1093	23.80	1124	26.61	1154	29.50	1212	35.46
34236	1800	1023	14.84	1060	17.74	1095	20.66	1126	23.45	1156	26.28	1185	29.16	1213	32.09	1240	35.07	1295	41.60
38040	2000	1129	19.63	1163	22.85	1195	26.06	1225	29.25	1253	32.38	1280	35.51	1306	38.67	1331	41.84	1381	48.55
41844	2200	1235	25.37	1266	28.89	1296	32.43	1325	36.01	<i>1352</i>	<i>39.52</i>	<i>1377</i>	<i>42.92</i>	<i>1402</i>	<i>46.40</i>	<i>1425</i>	<i>49.77</i>	<i>1472</i>	<i>56.91</i>

CFM	OV	6" SP		7" SP		8" SP		9" SP		10" SP		11" SP		12" SP		13" SP		14" SP	
		RPM	BHP	RPM	BHP	RPM	BHP	RPM	BHP	RPM	BHP	RPM	BHP	RPM	BHP	RPM	BHP	RPM	BHP
15216	800																		
17118	900																		
19020	1000																		
20922	1100	1110	27.32	1181	32.12														
22824	1200	1136	29.81	1202	34.78	1267	39.94												
24726	1300	1165	32.42	1228	37.67	1289	43.03	<i>1349</i>	<i>48.55</i>	<i>1410</i>	<i>54.41</i>								
26628	1400	1197	35.24	1257	40.72	1316	46.41	<i>1373</i>	<i>52.17</i>	<i>1428</i>	<i>57.95</i>	<i>1484</i>	<i>64.07</i>						
28530	1500	1232	38.31	1289	44.01	1345	49.89												

Size 44 CBD Belt Driven Centaxial

Wheel Diameter: 44.09"

Tip Speed, FPM = 11.54 x Fan RPM

Max. BHP = 36.2 x (RPM ÷ 1000)³

Inlet Diameter: 64.97"

Inlet Area: 23.02 ft.²

Outlet Area: 23.02 ft.²

LEGEND	
Class I fans = regular face	(Max. 918 RPM)
Class II fans = bold face	(Max. 1194 RPM)
Class III fans = <i>italic face</i>	(Max. 1515 RPM)
Underlined figures indicate maximum static efficiency.	

CFM	OV	0.5" SP		1" SP		1.5" SP		2" SP		2.5" SP		3" SP		3.5" SP		4" SP		5" SP	
		RPM	BHP	RPM	BHP	RPM	BHP	RPM	BHP	RPM	BHP	RPM	BHP	RPM	BHP	RPM	BHP	RPM	BHP
9208	400	303	1.01																
11510	500	334	1.32	412	2.50														
13812	600	369	1.68	439	3.06	502	4.50												
16114	700	407	2.14	470	3.69	528	5.32	582	7.03	633	8.79								
18416	800	448	2.73	505	4.41	557	6.21	607	8.08	654	10.01	700	12.04	745	14.15				
20718	900	489	3.42	542	5.22	590	7.22	636	9.27	680	11.37	723	13.57	763	15.74	804	18.11		
23020	1000	532	4.26	580	6.17	625	8.29	668	10.58	709	12.86	749	15.20	787	17.55	825	20.05	897	25.09
25322	1100	574	5.21	620	7.30	662	9.52	703	12.00	741	14.49	778	16.98	815	19.58	850	22.17	918	27.54
27624	1200	618	6.34	661	8.60	701	10.96	739	13.52	775	16.21	810	18.94	845	21.74	878	24.48	942	30.12
29926	1300	661	7.60	703	10.09	741	12.61	776	15.21	811	18.08	844	21.00	877	24.02	908	26.93	969	32.91
32228	1400	705	9.05	746	11.79	781	14.41	815	17.17	848	20.12	879	23.16	910	26.35	940	29.54	999	35.99
34530	1500	750	10.73	788	13.61	823	16.49	855	19.37	886	22.38	916	25.56	945	28.86	974	32.29	1030	39.15
36832	1600	795	12.61	831	15.67	865	18.77	895	21.76	925	24.92	954	28.21	982	31.64	1009	35.15	1063	42.51
41436	1800	885	17.02	918	20.46	950	23.99	978	27.35	1006	30.84	1032	34.30	1058	37.93	1083	41.66	1133	49.66
46040	2000	975	22.37	1007	26.32	1036	30.19	1063	34.00	1089	37.83	1113	41.57	1137	45.44	1160	49.34	<i>1206</i>	<i>57.65</i>
50644	2200	1067	28.93	1096	33.23	1123	37.48	1149	41.75	1173	45.91	<i>1196</i>	<i>50.05</i>	<i>1219</i>	<i>54.29</i>	<i>1241</i>	<i>58.54</i>	<i>1283</i>	<i>67.13</i>

CFM	OV	6" SP		7" SP		8" SP		9" SP		10" SP		11" SP		12" SP		13" SP		14" SP	
		RPM	BHP	RPM	BHP	RPM	BHP	RPM	BHP	RPM	BHP	RPM	BHP	RPM	BHP	RPM	BHP	RPM	BHP
18416	800																		
20718	900																		
23020	1000																		
25322	1100	984	33.17																
27624	1200	1004	36.00	1065	42.18														
29926	1300	1029	39.21	1086	45.59	1141	52.07	<i>1197</i>	<i>59.00</i>										
32228	1400	1055	42.46	1110	49.21	1163	56.07	<i>1215</i>	<i>63.12</i>	<i>1267</i>	<i>70.49</i>								
34530	1500	1084	46.04	1136	53.00	1188	60.34	<i>1237</i>	<i>67.58</i>	<i>1286</i>	<i>75.15</i>	<i>1334</i>	<i>82.83</i>	<i>1382</i>	<i>90.77</i>				
36832	1600	1115	49.84	1165	57.17	<i>1214</i>	<i>64.67</i>	<i>1262</i>	<i>72.37</i>	<i>1309</i>	<i>80.24</i>	<i>1354</i>	<i>88.04</i>	<i>1400</i>	<i>96.31</i>	<i>1445</i>	<i>104.65</i>	<i>1490</i>	<i>113.22</i>
41436	1800	1180	57.75	<i>1227</i>	<i>66.04</i>	<i>1272</i>	<i>74.20</i>	<i>1317</i>	<i>82.62</i>	<i>1360</i>	<i>90.95</i>	<i>1403</i>	<i>99.59</i>	<i>1445</i>	<i>108.33</i>	<i>1486</i>	<i>117.13</i>		
46040	2000	<i>1251</i>	<i>66.52</i>	<i>1294</i>	<i>75.54</i>	<i>1337</i>	<i>84.81</i>	<i>1378</i>	<i>93.84</i>	<i>1419</i>	<i>103.06</i>	<i>1459</i>	<i>112.31</i>	<i>1498</i>	<i>121.58</i>				
50644	2200	<i>1325</i>	<i>76.34</i>	<i>1366</i>	<i>86.04</i>	<i>1405</i>	<i>95.82</i>	<i>1444</i>	<i>105.89</i>	<i>1482</i>	<i>115.90</i>								

Size 49 CBD Belt Driven Centaxial

Wheel Diameter: 49.21"

Tip Speed, FPM = 12.88 x Fan RPM

Max. BHP = 62.7 x (RPM ÷ 1000)³

Inlet Diameter: 72.84"

Inlet Area: 28.93 ft.²

Outlet Area: 28.93 ft.²

LEGEND	
Class I fans = regular face	(Max. 823 RPM)
Class II fans = bold face	(Max. 1070 RPM)
Class III fans = <i>italic face</i>	(Max. 1358 RPM)
Underlined figures indicate maximum static efficiency.	

CFM	OV	0.5" SP		1" SP		1.5" SP		2" SP		2.5" SP		3" SP		3.5" SP		4" SP		5" SP	
		RPM	BHP	RPM	BHP	RPM	BHP	RPM	BHP	RPM	BHP	RPM	BHP	RPM	BHP	RPM	BHP	RPM	BHP
11572	400	273	1.28																
14465	500	301	1.67	370	3.14														
17358	600	333	2.14	394	3.83	451	5.67	505	7.64										
20251	700	367	2.71	423	4.66	474	6.68	522	8.80	568	11.04								
23144	800	403	3.43	454	5.54	501	7.83	545	10.15	588	12.63	628	15.11	668	17.75				
26037	900	441	4.34	488	6.59	531	9.10	572	11.69	611	14.30	649	17.03	685	19.79	721	22.70		
28930	1000	479	5.38	523	7.82	563	10.48	601	13.33	638	16.23	673	19.12	707	22.08	741	25.22	805	31.53
31823	1100	518	6.62	559	9.25	597	12.07	632	15.08	667	18.29	700	21.43	732	24.60	763	27.81	824	34.59
34716	1200	557	8.03	596	10.90	631	13.83	665	17.03	697	20.39	729	23.90	759	27.29	789	30.79	847	37.98
37609	1300	597	9.69	634	12.80	667	15.90	699	19.21	730	22.79	759	26.42	788	30.16	817	33.98	871	41.44
40502	1400	637	11.56	672	14.90	704	18.25	734	21.69	763	25.33	792	29.28	819	33.22	846	37.27	898	45.30
43395	1500	677	13.66	711	17.29	742	20.90	770	24.47	798	28.28	825	32.28	851	36.43	877	40.77	926	49.26
46288	1600	717	16.01	750	19.93	780	23.80	807	27.58	833	31.47	859	35.60	884	39.89	909	44.43	956	53.50
52074	1800	799	21.68	829	26.07	857	30.47	882	34.69	906	38.95	930	43.40	953	47.93	975	52.54	1019	62.46
57860	2000	881	28.58	908	33.39	934	38.27	959	43.18	982	47.97	1003	52.60	1024	57.40	1045	62.37	<i>1086</i>	<i>72.77</i>
63646	2200	963	36.84	989	42.26	1013	47.60	1036	52.94	1058	58.27	<i>1079</i>	<i>63.55</i>	<i>1099</i>	<i>68.80</i>	<i>1118</i>	<i>74.00</i>	<i>1156</i>	<i>84.90</i>

CFM	OV	6" SP		7" SP		8" SP		9" SP		10" SP		11" SP		12" SP		13" SP		14" SP	
		RPM	BHP	RPM	BHP	RPM	BHP	RPM	BHP	RPM	BHP	RPM	BHP	RPM	BHP	RPM	BHP	RPM	BHP
23144	800																		
26037	900																		
28930	1000																		
31823	1100	883	41.66																
34716	1200	902	45.34	955	52.86	1009	60.97												
37609	1300	924	49.27	975	57.29	1024	65.40	<i>1074</i>	<i>74.11</i>										
40502	1400	948	53.43	997 </															

Size 55 CBD Belt Driven Centaxial

Wheel Diameter: 55.12"
 Tip Speed, FPM = 14.43 x Fan RPM
 Max. BHP = 110.5 x (RPM ÷ 1000)³

Inlet Diameter: 81.09"
 Inlet Area: 35.88 ft.²
 Outlet Area: 35.88 ft.²

LEGEND
 Class I fans = regular face (Max. 735 RPM)
 Class II fans = **bold face** (Max. 955 RPM)
 Class III fans = *italic face* (Max. 1212 RPM)
Underlined figures indicate maximum static efficiency.

CFM	OV	0.5" SP		1" SP		1.5" SP		2" SP		2.5" SP		3" SP		3.5" SP		4" SP		5" SP	
		RPM	BHP	RPM	BHP	RPM	BHP	RPM	BHP	RPM	BHP	RPM	BHP	RPM	BHP	RPM	BHP	RPM	BHP
14352	400	242	1.57																
17940	500	267	2.06	330	3.92														
21528	600	295	2.63	351	4.78	401	7.00												
25116	700	325	3.33	376	5.78	421	8.24	465	10.94	506	13.70								
28704	800	357	4.22	403	6.85	445	9.68	485	12.60	523	15.63	559	18.72	596	22.11				
32292	900	390	5.30	432	8.09	471	11.23	508	14.44	543	17.68	577	21.07	610	24.56	642	28.14		
35880	1000	424	6.60	463	9.60	499	12.91	534	16.52	567	20.09	598	23.63	629	27.37	659	31.20	717	39.12
39468	1100	458	8.09	495	11.36	529	14.86	561	18.65	592	22.58	622	26.52	651	30.49	679	34.52	734	42.99
43056	1200	493	9.84	528	13.41	559	17.00	590	21.05	619	25.25	647	29.50	675	33.86	701	38.07	753	46.98
46644	1300	528	11.84	561	15.68	591	19.56	620	23.72	647	28.07	674	32.71	700	37.34	725	41.90	774	51.24
50232	1400	563	14.10	595	18.29	624	22.47	650	26.64	677	31.31	702	36.08	727	41.09	751	46.05	798	56.06
53820	1500	598	16.63	629	21.17	657	25.66	682	30.07	707	34.78	731	39.73	755	45.01	778	50.32	823	61.05
57408	1600	634	19.55	663	24.33	690	29.13	715	33.92	738	38.70	761	43.79	784	49.24	806	54.80	849	66.21
64584	1800	706	26.41	733	31.85	758	37.27	781	42.59	803	47.96	824	53.39	844	58.89	865	64.91	904	77.15
71760	2000	778	34.74	803	40.81	826	46.78	848	52.79	869	58.78	888	64.56	907	70.54	926	76.76	963	89.77
78936	2200	851	44.86	874	51.52	896	58.20	917	64.90	936	71.33	955	77.92	973	84.44	990	90.88	1024	104.38

CFM	OV	6" SP		7" SP		8" SP		9" SP		10" SP		11" SP		12" SP		13" SP		14" SP	
		RPM	BHP	RPM	BHP	RPM	BHP	RPM	BHP	RPM	BHP	RPM	BHP	RPM	BHP	RPM	BHP	RPM	BHP
28704	800																		
32292	900																		
35880	1000																		
39468	1100	786	51.60																
43056	1200	803	56.25	851	65.69														
46644	1300	822	61.05	868	71.08	912	81.17	957	92.01										
50232	1400	843	66.18	887	76.69	930	87.55	971	98.36	1012	109.64								
53820	1500	866	71.72	908	82.67	949	93.94	989	105.48	1028	117.19	1066	129.01	1105	141.61				
57408	1600	890	77.47	931	89.16	970	100.78	1008	112.64	1046	125.03	1082	137.17	1119	150.14	1155	163.12	1192	176.90
64584	1800	943	90.12	980	102.85	1016	115.55	1052	128.65	1087	141.86	1121	155.16	1155	168.96	1188	182.77		
71760	2000	999	103.60	1034	117.85	1067	131.79	1101	146.29	1133	160.32	1165	174.71	1197	189.51				
78936	2200	1058	118.87	1090	133.69	1122	149.23	1153	164.83	1184	180.66								

Size 63 CBD Belt Driven Centaxial

Wheel Diameter: 62.99"
 Tip Speed, FPM = 16.49 x Fan RPM
 Max. BHP = 215 x (RPM ÷ 1000)³

Inlet Diameter: 92.91"
 Inlet Area: 47.08 ft.²
 Outlet Area: 47.08 ft.²

LEGEND
 Class I fans = regular face (Max. 642 RPM)
 Class II fans = **bold face** (Max. 835 RPM)
 Class III fans = *italic face* (Max. 1060 RPM)
Underlined figures indicate maximum static efficiency.

CFM	OV	0.5" SP		1" SP		1.5" SP		2" SP		2.5" SP		3" SP		3.5" SP		4" SP		5" SP	
		RPM	BHP	RPM	BHP	RPM	BHP	RPM	BHP	RPM	BHP	RPM	BHP	RPM	BHP	RPM	BHP	RPM	BHP
18832	400	212	2.05																
23540	500	234	2.71	289	5.14														
28248	600	259	3.47	307	6.23	352	9.25	394	12.44										
32956	700	285	4.37	329	7.54	369	10.82	407	14.32	443	17.96								
37664	800	314	5.59	354	9.04	390	12.70	425	16.53	458	20.48	490	24.61	522	29.02				
42372	900	343	7.02	379	10.63	413	14.74	446	19.05	476	23.23	506	27.71	535	32.34	563	37.05		
47080	1000	373	8.75	406	12.59	438	17.00	468	21.66	497	26.37	524	31.00	551	35.89	578	41.08	628	51.32
51788	1100	403	10.73	435	15.01	464	19.52	492	24.49	519	29.64	545	34.76	570	39.91	595	45.29	643	56.40
56496	1200	433	12.99	463	17.60	491	22.43	518	27.72	543	33.19	568	38.88	591	44.29	615	50.11	660	61.71
61204	1300	464	15.65	493	20.72	519	25.79	544	31.19	568	36.97	591	42.94	614	49.09	636	55.12	679	67.45
65912	1400	494	18.55	523	24.18	547	29.47	571	35.16	594	41.16	616	47.45	638	54.06	659	60.60	700	73.74
70620	1500	526	22.04	553	28.01	577	33.84	599	39.66	621	45.88	642	52.39	662	59.06	682	66.00	722	80.30
75328	1600	557	25.82	583	32.21	606	38.42	627	44.54	648	51.00	668	57.65	688	64.77	707	71.99	745	87.13
84744	1800	620	34.84	644	42.06	666	49.22	686	56.19	705	63.18	723	70.21	741	77.58	759	85.36	793	101.37
94160	2000	684	45.99	706	54.01	726	61.86	745	69.69	763	77.46	780	85.18	797	93.18	813	101.13	845	118.05
103576	2200	748	59.36	768	68.09	787	76.81	805	85.49	822	94.07	838	102.49	854	111.14	869	119.65	899	137.49

CFM	OV	6" SP		7" SP		8" SP		9" SP		10" SP		11" SP		12" SP		13" SP		14" SP	
		RPM	BHP	RPM	BHP	RPM	BHP	RPM	BHP	RPM	BHP	RPM	BHP	RPM	BHP	RPM	BHP	RPM	BHP
37664	800																		
42372	900																		
47080	1000																		
51788	1100	689	67.87																
56496	1200	703	73.65	745	86.05	788	99.51												
61204	1300	720	80.03	760	93.10	799	106.55	838	120.65										
65912	1400	739	86.93	777	100.55	814	114.55	851	129.25	887	144.15								
70620	1500	759	94.13	796	108.61	832	123.48	866	138.17	900	153.49	934	169.42	968	185.92				
75328	1																		

Size 71 CBD Belt Driven Centaxial

Wheel Diameter: 70.86"

Tip Speed, FPM = 18.55 x Fan RPM

Max. BHP = 388 x (RPM ÷ 1000)³

Inlet Diameter: 104.34"

Inlet Area: 59.37 ft.²

Outlet Area: 59.37 ft.²

LEGEND	
Class I fans = regular face	(Max. 571 RPM)
Class II fans = bold face	(Max. 742 RPM)
Class III fans = <i>italic face</i>	(Max. 942 RPM)
<u>Underlined figures indicate maximum static efficiency.</u>	

CFM	OV	0.5" SP		1" SP		1.5" SP		2" SP		2.5" SP		3" SP		3.5" SP		4" SP		5" SP	
		RPM	BHP	RPM	BHP	RPM	BHP	RPM	BHP	RPM	BHP	RPM	BHP	RPM	BHP	RPM	BHP	RPM	BHP
23748	400	189	2.62																
29685	500	208	3.43	256	6.43														
35622	600	230	4.38	273	7.90	312	11.59												
41559	700	253	5.52	292	9.51	328	13.70	362	18.14	394	22.74								
47496	800	278	7.00	314	11.38	346	15.99	377	20.79	407	25.88	435	31.00	463	36.44				
53433	900	304	8.82	337	13.48	367	18.66	395	23.85	423	29.37	449	34.88	475	40.76	500	46.72		
59370	1000	330	10.93	360	15.84	389	21.48	415	27.24	441	33.21	466	39.29	490	45.47	513	51.73	558	64.81
65307	1100	357	13.45	385	18.77	412	24.65	437	30.97	461	37.46	484	43.89	506	50.31	528	57.02	571	71.12
71244	1200	384	16.34	411	22.21	435	28.14	459	34.81	482	41.88	504	48.99	525	55.97	546	63.19	586	77.81
77181	1300	411	19.62	437	26.03	460	32.40	482	39.15	504	46.61	525	54.30	545	61.91	564	69.30	603	85.13
83118	1400	438	23.32	463	30.27	485	37.06	506	44.14	527	51.86	546	59.62	566	68.10	584	76.06	621	92.81
89055	1500	466	27.64	490	35.15	511	42.41	531	49.85	550	57.52	569	65.81	588	74.67	605	83.11	640	100.85
94992	1600	493	32.29	516	40.29	537	48.23	556	56.03	574	63.96	593	72.77	610	81.46	627	90.60	661	109.76
106866	1800	549	43.62	570	52.61	590	61.73	608	70.57	625	79.42	641	88.28	657	97.56	673	107.37	704	127.97
118740	2000	606	57.67	625	67.58	643	77.52	660	87.41	676	97.19	691	106.84	706	116.85	721	127.26	<i>750</i>	<i>148.94</i>
130614	2200	662	74.18	680	85.23	697	96.24	713	107.16	729	118.37	743	128.88	757	139.66	771	150.77	<i>797</i>	<i>172.85</i>

CFM	OV	6" SP		7" SP		8" SP		9" SP		10" SP		11" SP		12" SP		13" SP		14" SP	
		RPM	BHP	RPM	BHP	RPM	BHP	RPM	BHP	RPM	BHP	RPM	BHP	RPM	BHP	RPM	BHP	RPM	BHP
47496	800																		
53433	900																		
59370	1000																		
65307	1100	612	85.61																
71244	1200	625	93.19	662	108.68														
77181	1300	640	101.25	675	117.46	710	134.59	<i>745</i>	<i>152.57</i>										
83118	1400	656	109.57	690	126.84	723	144.55	<i>755</i>	<i>162.50</i>	<i>788</i>	<i>181.91</i>								
89055	1500	674	118.80	706	136.54	738	155.24	<i>769</i>	<i>174.24</i>	<i>799</i>	<i>193.37</i>	<i>829</i>	<i>213.25</i>	<i>860</i>	<i>234.62</i>				
94992	1600	693	128.48	724	147.31	<i>755</i>	<i>166.97</i>	<i>785</i>	<i>186.93</i>	<i>814</i>	<i>207.05</i>	<i>842</i>	<i>227.16</i>	<i>870</i>	<i>247.96</i>	<i>898</i>	<i>269.43</i>	<i>927</i>	<i>292.43</i>
106866	1800	734	149.28	<i>763</i>	<i>170.51</i>	<i>791</i>	<i>191.56</i>	<i>818</i>	<i>212.50</i>	<i>845</i>	<i>234.14</i>	<i>872</i>	<i>256.61</i>	<i>898</i>	<i>279.03</i>	<i>924</i>	<i>302.18</i>		
118740	2000	<i>777</i>	<i>171.20</i>	<i>804</i>	<i>194.60</i>	<i>831</i>	<i>218.68</i>	<i>857</i>	<i>242.36</i>	<i>882</i>	<i>265.70</i>	<i>907</i>	<i>289.64</i>	<i>931</i>	<i>313.28</i>				
130614	2200	<i>823</i>	<i>196.51</i>	<i>849</i>	<i>221.88</i>	<i>873</i>	<i>246.89</i>	<i>897</i>	<i>272.60</i>										

Performance shown is for installation type B: Free inlet, ducted outlet. Power rating (BHP) does not include drive losses. Performance ratings do not include the effects of appurtenances in the airstream.

Performance Data – CDD

Capacities shown in the performance tables that follow are for standard air conditions: 70°F at sea level (.075 lbs./cu. ft. air density).

Catalog Numbering System

To identify a specific fan for ordering or engineering specification, it is necessary to show the complete catalog number as outlined in the example to the right.

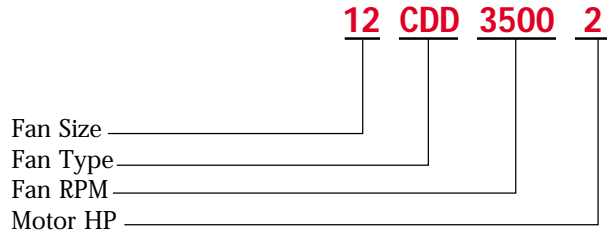

CDD Direct Driven Centaxial – 60 Hz Speeds – 100% Width Wheels

SIZE	RPM	0.5" SP		1" SP		1.5" SP		2" SP		2.5" SP		3" SP		4" SP		5" SP		6"SP		7"SP			
		CFM	BHP	CFM	BHP	CFM	BHP	CFM	BHP	CFM	BHP	CFM	BHP	CFM	BHP	CFM	BHP	CFM	BHP	CFM	BHP		
12	3500	3034	1.62	2904	1.74	2776	1.85	2651	1.95	2516	2.04	2356	2.13	2052	2.27	1751	2.34						
14	1750	1987	0.43	1664	0.50	1326	0.53	4117	3.28	3973	3.43	3831	3.56	3683	3.69	3327	3.96	2987	4.16	2653	4.28	2243	4.24
	3500	4410	2.92	4263	3.11	4117	3.28	3973	3.43	3831	3.56	3683	3.69	3327	3.96	2987	4.16	2653	4.28	2243	4.24		
16	1750	2927	0.75	2599	0.85	2197	0.93	1822	0.97														
	3500	6348	5.21	6183	5.49	6018	5.75	5853	6.00	5693	6.21	5535	6.40	5199	6.77	4788	7.16	4394	7.47	4035	7.68		
18	1750	4569	1.33	4268	1.48	3885	1.62	3474	1.73	3051	1.79	2486	1.73										
	3500	9528	9.75	9403	10.05	9273	10.34	9139	10.64	8999	10.93	8853	11.22	8537	11.81	8169	12.39	7770	12.94	7368	13.42		
20	1750	6363	2.22	6046	2.42	5664	2.62	5222	2.80	4759	2.95	4292	3.04										
22	1160	5704	1.23	5032	1.41	4253	1.55	3341	1.55														
	1750	9046	3.85	8705	4.14	8323	4.42	7866	4.70	7369	4.96	6854	5.17	5791	5.42								
25	1160	8265	2.13	7589	2.40	6748	2.64	5859	2.80	4823	2.79												
	1750	12947	6.81	12576	7.22	12174	7.62	11728	8.02	11207	8.42	10647	8.79	9489	9.39	8298	9.72						
28	1160	12763	3.70	11909	4.18	10946	4.55	9966	4.90	8990	5.17	7915	5.30										
	1750	19920	11.66	19401	12.48	18861	13.26	18295	13.98	17690	14.62	17051	15.19	15757	16.26	14445	17.23	13170	17.97	11637	18.12		
32	1160	18533	6.53	17606	7.26	16581	7.87	15481	8.39	14376	8.89	13262	9.30	10760	9.55								
	1750	28699	20.92	28122	22.11	27526	23.26	26910	24.35	26272	25.38	25599	26.32	24160	27.96	22703	29.50	21228	30.94	19763	32.11		
35	870	20597	5.72	19176	6.42	17774	7.03	16204	7.65	14363	7.98	11842	7.74										
	1160	28316	12.72	27221	13.77	26146	14.74	25110	15.60	24063	16.40	22938	17.22	20436	18.67	17229	18.77						
39	1750	43654	41.50	42920	43.21	42190	44.86	41465	46.44	40745	47.97	40029	49.44	38636	52.16	37268	54.66	35853	57.07				
	870	28653	9.44	27048	10.46	25512	11.34	23902	12.17	22130	13.01	20106	13.49	17229	14.77	15757	16.26	14445	17.23	13170	17.97	11637	18.12
44	1160	39155	21.20	37933	22.69	36727	24.07	35546	25.35	34399	26.51	33238	27.62	30717	29.86	27868	31.71	24391	31.97				
	870	40690	16.22	38880	17.71	37121	19.05	35405	20.24	33586	21.40	31626	22.60	27009	23.82	246025	49.35	43171	52.52	40044	55.34	36452	56.46

CDD Direct Driven Centaxial – 50 Hz Speeds – 100% Width Wheels

SIZE	RPM	0.5" SP		1" SP		1.5" SP		2" SP		2.5" SP		3" SP		4" SP		5" SP		6"SP		7"SP		
		CFM	BHP	CFM	BHP	CFM	BHP	CFM	BHP	CFM	BHP	CFM	BHP	CFM	BHP	CFM	BHP	CFM	BHP	CFM	BHP	
12	2850	2416	0.91	2259	1.00	2103	1.08	1914	1.15	1723	1.21	1547	1.25									
14	1450	1537	0.26	1124	0.30																	
	2850	3530	1.63	3350	1.77	3175	1.89	2995	2.00	2780	2.11	2558	2.20	2151	2.31							
16	1450	2304	0.45	1846	0.53	1368	0.55															
	2850	5100	2.89	4898	3.11	4697	3.30	4503	3.46	4300	3.61	4064	3.77	3568	4.04	3115	4.19	2508	4.11			
18	1450	3678	0.79	3248	0.91	2748	1.00	2169	1.00													
	2850	7707	5.35	7549	5.59	7382	5.83	7205	6.07	7014	6.30	6800	6.54	6317	6.99	5816	7.37	5297	7.64	4756	7.76	
20	1450	5157	1.31	4724	1.48	4188	1.63	3623	1.73	2942	1.70											
22	975	4585	0.78	3688	0.91																	
	1450	7370	2.27	6926	2.50	6365	2.73	5754	2.92	5121	3.05	4403	3.06									
25	975	6730	1.33	5794	1.55	4740	1.68															
	1450	10590	3.98	10117	4.31	9564	4.65	8902	4.97	8215	5.24	7500	5.43	5812	5.38							
28	975	10439	2.32	9339	2.67	8171	2.96	7001	3.14													
	1450	16311	6.85	15667	7.50	14978	8.09	14221	8.59	13440	9.03	12656	9.47	11095	10.16	9173	10.17					
32	975	15261	4.06	14089	4.62	12785	5.06	11460	5.45	10155	5.72											
	1450	23563	12.21	22851	13.17	22104	14.07	21310	14.88	20453	15.59	19570	16.23	17803	17.47	16044	18.44	14080	18.83			
35	750	17325	3.83	15707	4.39	13915	4.91	11662	5.11													
	975	23416	7.82	22127	8.66	20892	9.38	19607	10.06	18195	10.75	16592	11.18									
39	1450	35892	24.06	35010	25.44	34135	26.74	33270	27.98	32421	29.14	31594	30.21	29916	32.23	28087	34.28	26089	36.14	23801	36.94	
	750	24219	6.28	22400	7.10	20551	7.82	18442	8.50	15822	8.64											
44	975	32482	12.96	31040	14.16	29638	15.23	28271	16.18	26822	17.10	25261	18.06	21588	19.05							
	750	34535	10.73	32461	11.95	30466	13.00	28321	14.01	25932	14.95	23112	15.26									
44	975	46019	22.37	44395	24.10	42794	25.70	41247	27.14	39715	28.46	38111	29.75	34583	32.37	30382	33.53	23988	31.66			

Performance shown is for installation type B: Free inlet, ducted outlet. Power rating (BHP) does not include drive losses. Performance ratings do not include the effects of appurtenances in the airstream.

Size 12 CDD Direct Drive Centaxial – Partial Width Wheels

Wheel Diameter: 12.40"

Inlet Diameter: 18.69"

Inlet & Outlet Area: 1.91 ft.²

Tip Speed FPM = 3.25 x Fan RPM

Max. BHP = 0.055 (RPM ÷ 1000)³ x % of Wheel Width

CFM	OV	0.25" SP	0.5" SP	0.75" SP	1" SP	1.5" SP	2" SP	2.5" SP	3" SP	4" SP	5" SP	6" SP	7" SP
		PW BHP	PW BHP	PW BHP	PW BHP	PW BHP	PW BHP	PW BHP	PW BHP	PW BHP	PW BHP	PW BHP	PW BHP
764	400	25 0.38	25 0.41	26 0.43	26 0.46	28 0.51	29 0.56	30 0.62	32 0.69	37 0.85	44 1.02		
955	500	31 0.48	31 0.51	32 0.54	33 0.57	34 0.64	36 0.70	38 0.77	41 0.86	47 1.06	55 1.28		
1146	600	37 0.57	38 0.61	39 0.65	39 0.69	41 0.76	43 0.84	46 0.93	49 1.04	56 1.27	65 1.53		
1337	700	43 0.67	44 0.71	45 0.76	46 0.80	48 0.89	50 0.98	53 1.08	57 1.21	65 1.48	76 1.79		
1528	800	49 0.76	50 0.82	51 0.86	53 0.92	55 1.02	58 1.12	61 1.24	65 1.38	74 1.69	87 2.04		
1719	900	55 0.86	57 0.92	58 0.97	59 1.03	62 1.15	65 1.26	68 1.39	73 1.55	84 1.90	98 2.30		
1910	1000	62 0.96	63 1.02	64 1.08	66 1.14	69 1.27	72 1.40	76 1.55	81 1.73	93 2.11			
2101	1100	68 1.05	69 1.12	71 1.19	72 1.26	76 1.40	79 1.55	84 1.70	89 1.90				
2292	1200	74 1.15	76 1.22	77 1.30	79 1.37	83 1.53	86 1.69	91 1.86	97 2.07				
2483	1300	80 1.24	82 1.33	84 1.40	86 1.49	89 1.65	94 1.83	99 2.01					
2674	1400	86 1.34	88 1.43	90 1.51	92 1.60	96 1.78							
2865	1500	92 1.43	94 1.53	96 1.62	99 1.72								
3056	1600	99 1.53											

LEGEND 3500 RPM = Normal Face

Size 14 CDD Direct Drive Centaxial – Partial Width Wheels

Wheel Diameter: 13.98"

Inlet Diameter: 20.88"

Inlet/Outlet Area: 2.37 ft.²

Tip Speed FPM = 3.66 x Fan RPM

Max. BHP = 0.100 (RPM ÷ 1000)³ x % of Wheel Width

CFM	OV	0.25" SP	0.5" SP	0.75" SP	1" SP	1.5" SP	2" SP	2.5" SP	3" SP	4" SP	5" SP	6" SP	7" SP
		PW BHP	PW BHP	PW BHP	PW BHP	PW BHP	PW BHP	PW BHP	PW BHP	PW BHP	PW BHP	PW BHP	PW BHP
948	400	44 0.17	48 0.21	51 0.24	57 0.28	71 0.38	24 0.82	25 0.88	26 0.95	28 1.13	32 1.32	36 1.53	42 1.79
1185	500	56 0.22	60 0.26	64 0.30	71 0.36	89 0.47	30 1.02	31 1.10	32 1.19	36 1.41	40 1.65	45 1.91	53 2.24
1422	600	67 0.26	72 0.31	77 0.36	85 0.43	35 1.13	36 1.23	37 1.32	39 1.42	43 1.69	48 1.98	54 2.29	63 2.69
1659	700	78 0.30	83 0.36	90 0.41	100 0.50	40 1.32	42 1.43	43 1.54	45 1.66	50 1.97	56 2.31	63 2.68	74 3.14
1896	800	89 0.35	95 0.41	44 1.32	44 1.38	46 1.51	48 1.64	49 1.76	51 1.90	57 2.26	63 2.64	71 3.06	85 3.58
2133	900	100 0.39	48 1.41	49 1.48	50 1.56	52 1.70	54 1.84	56 1.98	58 2.14	64 2.54	71 2.97	80 3.44	95 4.03
2370	1000	53 1.49	54 1.57	55 1.65	56 1.73	58 1.89	60 2.05	62 2.20	64 2.37	71 2.82	79 3.30	89 3.82	
2607	1100	58 1.63	59 1.73	60 1.81	61 1.90	63 2.08	66 2.25	68 2.42	71 2.61	78 3.10	87 3.63	98 4.21	
2844	1200	63 1.78	64 1.88	66 1.97	67 2.07	69 2.27	72 2.46	74 2.64	77 2.85	85 3.39	95 3.96		
3081	1300	69 1.93	70 2.04	71 2.14	72 2.25	75 2.45	78 2.66	80 2.86	84 3.09	93 3.67			
3318	1400	74 2.08	75 2.20	77 2.30	78 2.42	81 2.64	84 2.86	87 3.08	90 3.32	100 3.95			
3555	1500	79 2.23	81 2.35	82 2.47	83 2.59	86 2.83	89 3.07	93 3.30	97 3.56				
3792	1600	85 2.38	86 2.51	87 2.63	89 2.77	92 3.02	95 3.27	99 3.52					
4029	1700	90 2.53	91 2.67	93 2.80	95 2.94	98 3.21							
4266	1800	95 2.67	97 2.82	98 2.96	100 3.11								
4503	1900	100 2.82											

LEGEND 1750 RPM=Bold Face 3500 RPM=Normal Face

Size 16 CDD Direct Drive Centaxial – Partial Width Wheels

Wheel Diameter: 15.75"

Inlet Diameter: 23.63"

Inlet/Outlet Area: 3.04 ft.²

Tip Speed FPM = 4.12 x Fan RPM

Max. BHP = 0.182 (RPM ÷ 1000)³ x % of Wheel Width

CFM	OV	0.25" SP	0.5" SP	0.75" SP	1" SP	1.5" SP	2" SP	2.5" SP	3" SP	4" SP	5" SP	6" SP	7" SP
		PW BHP	PW BHP	PW BHP	PW BHP	PW BHP	PW BHP	PW BHP	PW BHP	PW BHP	PW BHP	PW BHP	PW BHP
1216	400	39 0.27	42 0.31	44 0.35	47 0.40	55 0.51	67 0.65		22 1.41	23 1.58	25 1.83	28 2.07	30 2.31
1520	500	49 0.34	52 0.39	55 0.44	58 0.50	69 0.64	83 0.81	27 1.66	27 1.76	29 1.98	32 2.28	35 2.58	38 2.89
1824	600	59 0.41	62 0.47	66 0.53	70 0.60	83 0.77	100 0.97	32 1.99	33 2.11	35 2.38	38 2.74	42 3.10	45 3.47
2128	700	69 0.48	73 0.55	77 0.62	82 0.70	97 0.90	36 2.18	37 2.32	38 2.46	41 2.77	44 3.20	48 3.62	53 4.05
2432	800	79 0.54	83 0.62	88 0.70	94 0.80	40 2.32	42 2.49	43 2.65	44 2.81	47 3.17	51 3.65	55 4.13	60 4.63
2736	900	89 0.61	93 0.70	99 0.79	44 2.43	45 2.61	47 2.80	48 2.98	49 3.16	53 3.56	57 4.11	62 4.65	68 5.21
3040	1000	98 0.68	48 2.50	49 2.60	49 2.70	51 2.90	52 3.12	53 3.32	55 3.52	58 3.96	63 4.57	69 5.17	75 5.79
3344	1100	52 2.64	53 2.74	53 2.86	54 2.97	56 3.20	57 3.43	59 3.65	60 3.87	64 4.35	70 5.02	76 5.68	83 6.36
3648	1200	57 2.88	57 2.99	58 3.12	59 3.24	61 3.49	62 3.74	64 3.98	66 4.22	70 4.75	76 5.48	83 6.20	90 6.94
3952	1300	61 3.12	62 3.24	63 3.38	64 3.51	66 3.78	68 4.05	69 4.31	71 4.57	76 5.15	83 5.93	90 6.72	98 7.52
4256	1400	66 3.36	67 3.49	68 3.64	69 3.78	71 4.07	73 4.36	75 4.64	77 4.92	82 5.54	89 6.39	97 7.24	
4560	1500	71 3.59	72 3.74	73 3.90	74 4.05	76 4.36	78 4.67	80 4.97	82 5.27	88 5.94	95 6.85		
4864	1600	76 3.83	77 3.99	78 4.16	79 4.32	81 4.65	83 4.99	85 5.31	88 5.62	94 6.33			
5168	1700	80 4.07	81 4.24	82 4.42	84 4.59	86 4.94	88 5.30	91 5.64	93 5.98	99 6.73			
5472	1800	85 4.31	86 4.49	87 4.68	89 4.86	91 5.23	93 5.61	96 5.97	99 6.33				
5776	1900	90 4.55	91 4.74	92 4.94	93 5.13	96 5.52	99 5.92						
6080	2000	95 4.79	96 4.99	97 5.20	98 5.40								
6384	2100	99 5.03											

LEGEND 1750 RPM=Bold Face 3500 RPM=Normal Face

Performance shown is for installation type B: Free inlet, ducted outlet.
Performance ratings do not include the effects of appurtenances in the airstream.

PW = % of Wheel Width

Size 18 CDD Direct Drive Centaxial – Partial Width Wheels

Wheel Diameter: 17.72"

Inlet Diameter: 26.38"

Inlet/Outlet Area: 3.79 ft.²

Tip Speed FPM = 4.64 x Fan RPM

Max. BHP = 0.335 (RPM ÷ 1000)³ x % of Wheel Width

CFM	OV	0.25" SP		0.5" SP		0.75" SP		1" SP		1.5" SP		2" SP		2.5" SP		3" SP		4" SP		5" SP		6" SP		7" SP		
		PW	BHP	PW	BHP	PW	BHP	PW	BHP	PW	BHP	PW	BHP	PW	BHP	PW	BHP	PW	BHP	PW	BHP	PW	BHP	PW	BHP	
1516	400	32	0.41	33	0.44	34	0.48	36	0.53	39	0.63	44	0.75	50	0.89											
1895	500	40	0.51	41	0.55	43	0.60	44	0.66	49	0.79	55	0.94	62	1.11			22	2.62	23	2.87	24	3.16	26	3.45	
2274	600	48	0.61	50	0.66	51	0.72	53	0.79	59	0.95	65	1.13	75	1.33			27	3.15	28	3.45	29	3.79	31	4.14	
2653	700	56	0.71	58	0.77	60	0.84	62	0.92	68	1.11	76	1.32	87	1.56			30	3.36	31	3.67	32	4.02	34	4.42	
3032	800	64	0.81	66	0.88	69	0.96	71	1.05	78	1.26	87	1.51	99	1.78			34	3.84	36	4.19	37	4.60	39	5.05	
3411	900	73	0.91	75	0.99	77	1.08	80	1.18	88	1.42	98	1.70	38	4.14			39	4.32	40	4.72	42	5.17	44	5.68	
3790	1000	81	1.02	83	1.10	86	1.20	89	1.31	98	1.58	41	4.41	42	4.60			43	4.80	44	5.24	46	5.75	49	6.31	
4169	1100	89	1.12	91	1.21	94	1.32	98	1.45	45	4.65	46	4.85	46	5.06			47	5.28	49	5.77	51	6.32	54	6.94	
4548	1200	97	1.22	100	1.32	48	4.76	48	4.86	49	5.07	50	5.29	51	5.52			51	5.76	53	6.29	56	6.90	59	7.57	
4927	1300	51	4.93	52	5.04	52	5.15	52	5.27	53	5.49	54	5.74	55	5.98			56	6.24	58	6.82	60	7.47	63	8.21	
5306	1400	55	5.31	56	5.43	56	5.55	56	5.67	57	5.92	58	6.18	59	6.44			60	6.72	62	7.34	65	8.05	68	8.84	
5685	1500	59	5.69	60	5.82	60	5.95	60	6.08	61	6.34	62	6.62	63	6.90			64	7.20	67	7.86	70	8.62	73	9.47	
6064	1600	63	6.07	64	6.21	64	6.34	64	6.48	65	6.76	66	7.06	67	7.37			68	7.69	71	8.39	74	9.20	78	10.10	
6822	1800	71	6.83	72	6.98	72	7.13	73	7.29	74	7.61	75	7.94	76	8.29			77	8.65	80	9.44	84	10.35	88	11.36	
7580	2000	79	7.59	80	7.76	80	7.93	81	8.10	82	8.45	83	8.82	84	9.21			86	9.61	89	10.49	93	11.50	98	12.62	
7959	2100	83	7.97	84	8.14	84	8.32	85	8.51	86	8.87	87	9.27	88	9.67			90	10.09	93	11.01	97	12.07			

LEGEND 1750 RPM=Bold Face 3500 RPM=Normal Face

Size 20 CDD Direct Drive Centaxial – Partial Width Wheels

Wheel Diameter: 19.68"

Inlet Diameter: 29.53"

Inlet/Outlet Area: 4.76 ft.²

Tip Speed FPM = 5.15 x Fan RPM

Max. BHP = 0.571 (RPM ÷ 1000)³ x % of Wheel Width

CFM	OV	0.25" SP		0.5" SP		0.75" SP		1" SP		1.5" SP		2" SP		2.5" SP		3" SP		4" SP		5" SP		6" SP		7" SP	
		PW	BHP	PW	BHP	PW	BHP	PW	BHP	PW	BHP	PW	BHP	PW	BHP	PW	BHP	PW	BHP	PW	BHP	PW	BHP	PW	BHP
1904	400	29	0.62	30	0.66	31	0.71	31	0.76	34	0.88	36	1.02	40	1.18	44	1.35								
2380	500	37	0.78	37	0.83	38	0.89	39	0.95	42	1.10	46	1.28	50	1.48	55	1.69								
2856	600	44	0.93	45	1.00	46	1.07	47	1.14	50	1.32	55	1.53	60	1.77	67	2.02								
3332	700	51	1.09	52	1.16	54	1.24	55	1.33	59	1.54	64	1.79	70	2.07	78	2.36								
3808	800	59	1.24	60	1.33	61	1.42	63	1.52	67	1.76	73	2.04	80	2.36	89	2.70								
4284	900	66	1.40	67	1.49	69	1.60	71	1.71	76	1.98	82	2.30	90	2.66	100	3.03								
4760	1000	73	1.55	75	1.66	77	1.78	79	1.91	84	2.20	91	2.55												
5236	1100	80	1.71	82	1.83	84	1.96	87	2.10	92	2.42														
5712	1200	88	1.86	90	1.99	92	2.13	94	2.29																
6188	1300	95	2.02	97	2.16	100	2.31																		

LEGEND 1750 RPM = Normal Face

Size 22 CDD Direct Drive Centaxial – Partial Width Wheels

Wheel Diameter: 22.05"

Inlet Diameter: 33.47"

Inlet/Outlet Area: 6.11 ft.²

Tip Speed FPM = 5.77 x Fan RPM

Max. BHP = 1.011 (RPM ÷ 1000)³ x % of Wheel Width

CFM	OV	0.25" SP		0.5" SP		0.75" SP		1" SP		1.5" SP		2" SP		2.5" SP		3" SP		4" SP		5" SP		6" SP		7" SP	
		PW	BHP	PW	BHP	PW	BHP	PW	BHP	PW	BHP	PW	BHP	PW	BHP	PW	BHP	PW	BHP	PW	BHP	PW	BHP	PW	BHP
2444	400	41	0.46	43	0.53	45	0.60	49	0.68	57	0.89	73	1.13	33	1.65	36	1.84	42	2.29						
3055	500	51	0.58	54	0.66	57	0.75	61	0.86	72	1.11	91	1.42	41	2.06	45	2.30	53	2.86						
3666	600	61	0.69	64	0.79	68	0.90	73	1.03	86	1.34	47	2.19	50	2.47	53	2.77	63	3.43						
4277	700	72	0.81	75	0.92	79	1.05	85	1.20	51	2.27	54	2.56	58	2.88	62	3.23	74	4.00						
4888	800	82	0.93	86	1.05	91	1.20	97	1.37	59	2.60	62	2.92	66	3.29	71	3.69	84	4.57						
5499	900	92	1.04	96	1.19	62	2.47	63	2.62	66	2.92	70	3.29	75	3.70	80	4.15	95	5.15						
6110	1000	66	2.46	68	2.60	69	2.75	70	2.91	73	3.24	78	3.65	83	4.11	89	4.61								
6721	1100	73	2.71	74	2.86	76	3.02	77	3.20	81	3.57	85	4.02	91	4.52	98	5.07								
7332	1200	80	2.96	81	3.12	83	3.29	84	3.49	88	3.89	93	4.38	99	4.94										
7943	1300	86	3.20	88	3.38	89	3.57	91	3.78	95	4.22														
8554	1400	93	3.45	95	3.64	96	3.84	98	4.07																
9165	1500	100	3.69																						

LEGEND 1160 RPM=Bold Face 1750 RPM=Normal Face

Performance shown is for installation type B: Free inlet, ducted outlet.
Performance ratings do not include the effects of appurtenances in the airstream.

PW = % of Wheel Width

Size 25 CDD Direct Drive Centaxial – Partial Width Wheels

Wheel Diameter: 24.80"

Inlet Diameter: 37.41"

Inlet/Outlet Area: 7.63 ft.²

Tip Speed FPM = 6.49 x Fan RPM

Max. BHP = 1.82 (RPM ÷ 1000)³ x % of Wheel Width

CFM	OV	0.25" SP	0.5" SP	0.75" SP	1" SP	1.5" SP	2" SP	2.5" SP	3" SP	4" SP	5" SP	6" SP	7" SP
		PW BHP	PW BHP	PW BHP	PW BHP	PW BHP	PW BHP	PW BHP	PW BHP	PW BHP	PW BHP	PW BHP	PW BHP
3052	400	36 0.71	37 0.79	38 0.87	40 0.97	45 1.19	52 1.46	63 1.77	29 2.52	32 3.02	37 3.58		
3815	500	45 0.89	46 0.98	48 1.09	50 1.21	57 1.49	65 1.82	79 2.21	36 3.15	40 3.78	46 4.47		
4578	600	54 1.07	55 1.18	58 1.31	60 1.45	68 1.79	78 2.19	95 2.65	43 3.78	48 4.53	55 5.36		
5341	700	62 1.25	65 1.38	67 1.52	70 1.69	79 2.09	91 2.55	48 4.01	50 4.41	56 5.29	64 6.26		
6104	800	71 1.43	74 1.57	77 1.74	80 1.93	90 2.39	52 4.17	54 4.59	57 5.04	64 6.04	74 7.15		
6867	900	80 1.61	83 1.77	86 1.96	90 2.17	57 4.31	59 4.70	61 5.16	64 5.67	72 6.80	83 8.04		
7630	1000	89 1.79	92 1.97	96 2.18	61 4.38	63 4.79	65 5.22	68 5.73	72 6.30	80 7.55	92 8.94		
8393	1100	98 1.96	65 4.41	66 4.61	67 4.82	69 5.27	72 5.74	75 6.31	79 6.93	88 8.31			
9156	1200	70 4.60	71 4.82	72 5.03	73 5.26	75 5.74	78 6.26	82 6.88	86 7.56	96 9.06			
9919	1300	76 4.99	77 5.22	78 5.45	79 5.69	82 6.22	85 6.78	89 7.45	93 8.19				
10682	1400	81 5.37	83 5.62	84 5.87	85 6.13	88 6.70	91 7.30	95 8.03					
11445	1500	87 5.76	88 6.02	90 6.29	91 6.57	94 7.18	98 7.83	102 8.60					
12208	1600	93 6.14		96 6.70	97 7.01	101 7.66	104 8.35	109 9.17					
12971	1700	99 6.52											

LEGEND 1160 RPM=Bold Face 1750 RPM=Normal Face

Size 28 CDD Direct Drive Centaxial – Partial Width Wheels

Wheel Diameter: 27.95"

Inlet Diameter: 41.72"

Inlet/Outlet Area: 9.50 ft.²

Tip Speed FPM = 7.32 x Fan RPM

Max. BHP = 3.40 (RPM ÷ 1000)³ x % of Wheel Width

CFM	OV	0.25" SP	0.5" SP	0.75" SP	1" SP	1.5" SP	2" SP	2.5" SP	3" SP	4" SP	5" SP	6" SP	7" SP
		PW BHP	PW BHP	PW BHP	PW BHP	PW BHP	PW BHP	PW BHP	PW BHP	PW BHP	PW BHP	PW BHP	PW BHP
3800	400	29 0.99	30 1.10	31 1.22	32 1.34	35 1.58	38 1.87	42 2.19	48 2.54	24 3.92	26 4.53	29 5.18	33 5.92
4750	500	36 1.24	37 1.38	38 1.52	40 1.67	43 1.97	48 2.34	53 2.73	60 3.18	30 4.90	33 5.67	36 6.48	41 7.40
5700	600	43 1.49	45 1.65	46 1.82	48 2.01	52 2.37	57 2.80	63 3.28	72 3.82	36 5.88	39 6.80	43 7.78	49 8.88
6650	700	51 1.73	52 1.93	54 2.13	56 2.34	61 2.76	67 3.27	74 3.82	84 4.45	42 6.86	46 7.93	50 9.07	57 10.35
7600	800	58 1.98	60 2.20	62 2.43	64 2.67	69 3.16	76 3.74	85 4.37	96 5.09	48 7.84	53 9.07	58 10.37	65 11.83
8550	900	65 2.23	67 2.48	69 2.73	72 3.01	78 3.55	86 4.20	95 4.92	50 7.62	54 8.82	59 10.20	65 11.67	73 13.31
9500	1000	72 2.48	74 2.75	77 3.04	80 3.34	87 3.95	95 4.67	54 7.85	56 8.46	60 9.80	66 11.33	72 12.96	82 14.79
10450	1100	79 2.72	82 3.03	85 3.34	88 3.68	95 4.34	57 7.99	59 8.64	61 9.31	66 10.78	72 12.46	79 14.26	90 16.27
11400	1200	87 2.97	89 3.30	92 3.65	96 4.01	60 8.01	62 8.71	64 9.42	67 10.16	72 11.76	79 13.60	87 15.55	98 17.75
12350	1300	94 3.22	97 3.58	100 3.95	64 7.94	65 8.68	68 9.44	70 10.21	72 11.00	78 12.74	85 14.73	94 16.85	
13300	1400	66 7.41	67 7.79	68 8.17	69 8.56	71 9.35	73 10.16	75 10.99	78 11.85	84 13.72	92 15.86		
14250	1500	71 7.94	72 8.34	72 8.75	73 9.17	76 10.02	78 10.89	81 11.78	84 12.69	90 14.70	99 17.00		
15200	1600	75 8.47	76 8.90	77 9.34	78 9.78	81 10.69	83 11.61	86 12.56	89 13.54	96 15.69			
17100	1800	85 9.53	86 10.01	87 10.51	88 11.00	91 12.02	93 13.07	97 14.13					
19000	2000	94 10.59	95 11.12	97 11.67	98 12.22								
19950	2100	99 11.12	100 11.68										

LEGEND 1160 RPM=Bold Face 1750 RPM=Normal Face

Size 32 CDD Direct Drive Centaxial – Partial Width Wheels

Wheel Diameter: 31.50"

Inlet Diameter: 46.47"

Inlet/Outlet Area: 11.78 ft.²

Tip Speed FPM = 8.25 x Fan RPM

Max. BHP = 6.19 (RPM ÷ 1000)³ x % of Wheel Width

CFM	OV	0.25" SP	0.5" SP	0.75" SP	1" SP	1.5" SP	2" SP	2.5" SP	3" SP	4" SP	5" SP	6" SP	7" SP
		PW BHP	PW BHP	PW BHP	PW BHP	PW BHP	PW BHP	PW BHP	PW BHP	PW BHP	PW BHP	PW BHP	PW BHP
5890	500	31 1.91	32 2.08	33 2.25	33 2.43	36 2.80	38 3.19	41 3.64	44 4.13	55 5.23	26 7.65	28 8.58	30 9.57
7068	600	37 2.29	38 2.49	39 2.70	40 2.91	43 3.35	46 3.83	49 4.37	53 4.96	66 6.27	31 9.18	33 10.30	36 11.48
8246	700	43 2.67	44 2.91	46 3.15	47 3.40	50 3.91	53 4.47	57 5.10	62 5.78	77 7.32	36 10.71	39 12.02	42 13.40
9424	800	50 3.05	51 3.32	52 3.60	54 3.89	57 4.47	61 5.11	66 5.83	71 6.61	88 8.36	42 12.25	44 13.74	48 15.31
10602	900	56 3.43	57 3.74	59 4.05	60 4.37	64 5.03	68 5.75	74 6.56	80 7.43	99 9.41	47 13.78	50 15.45	54 17.23
11780	1000	62 3.81	64 4.15	65 4.50	67 4.86	71 5.59	76 6.38	82 7.28	89 8.26	49 13.63	52 15.31	55 17.17	60 19.14
12958	1100	68 4.19	70 4.57	72 4.95	74 5.34	78 6.15	84 7.02	90 8.01	98 9.09	54 15.00	57 16.84	61 18.89	66 21.05
14136	1200	75 4.58	76 4.98	78 5.40	80 5.83	85 6.71	91 7.66	98 8.74	55 14.53	59 16.36	62 18.37	67 20.60	72 22.97
15314	1300	81 4.96	83 5.40	85 5.85	87 6.31	92 7.27	99 8.30	58 14.79	60 15.75	63 17.72	67 19.90	72 22.32	77 24.88
16492	1400	87 5.34	89 5.81	91 6.30	94 6.80	99 7.83	61 14.92	63 15.93	64 16.96	68 19.09	73 21.43	78 24.04	83 26.80
17670	1500	93 5.72	95 6.23	98 6.75	63 13.89	64 14.93	66 15.99	67 17.07	73 20.45	78 22.96	83 25.75	89 28.71	
18848	1600	99 6.10	66 13.74	66 14.28	67 14.82	68 15.93	70 17.05	72 18.21	74 19.38	78 21.81	83 24.49	89 27.47	95 30.62
21204	1800	73 14.85	74 15.46	75 16.06	75 16.67	77 17.92	79 19.19	81 20.48	83 21.80	88 24.54	93 27.55		
23560	2000	81 16.50	82 17.17	83 17.84	84 18.52	86 19.91	88 21.32	90 22.76	92 24.22	98 27.27			
25916	2200	89 18.15	90 18.89	91 19.63	92 20.38	94 21.90	96 23.45	99 25.04					

LEGEND 1160 RPM=Bold Face 1750 RPM=Normal Face

Performance shown is for installation type B: Free inlet, ducted outlet.
Performance ratings do not include the effects of appurtenances in the airstream.

PW = % of Wheel Width

Size 35 CDD Direct Drive Centaxial – Partial Width Wheels

Wheel Diameter: 35.43"

Inlet Diameter: 51.97"

Inlet/Outlet Area: 14.73 ft.²

Tip Speed FPM = 9.28 x Fan RPM

Max. BHP = 12.12 (RPM ÷ 1000)³ x % of Wheel Width

CFM	OV	0.25" SP		0.5" SP		0.75" SP		1" SP		1.5" SP		2" SP		2.5" SP		3" SP		4" SP		5" SP		6" SP		7" SP			
		PW	BHP	PW	BHP	PW	BHP	PW	BHP	PW	BHP	PW	BHP	PW	BHP	PW	BHP	PW	BHP	PW	BHP	PW	BHP	PW	BHP		
7365	500	35	1.83	36	2.05	37	2.26	38	2.47	41	2.91	45	3.48	51	4.09	62	4.81	36	6.73	43	8.02			25	14.07	26	15.33
8838	600	41	2.20	43	2.45	44	2.71	46	2.96	50	3.50	55	4.17	62	4.91	75	5.78	43	8.07	51	9.63						
10311	700	48	2.57	50	2.86	52	3.16	54	3.45	58	4.08	64	4.87	72	5.73	87	6.74	50	9.42	60	11.23			29	16.41	30	17.88
11784	800	55	2.93	57	3.27	59	3.61	61	3.95	66	4.66	73	5.56	82	6.55	100	7.70	58	10.77	68	12.84			33	18.76	34	20.43
13257	900	62	3.30	64	3.68	67	4.06	69	4.44	75	5.24	82	6.26	92	7.37	58	9.95	65	12.11	77	14.44			37	21.10	39	22.99
14730	1000	69	3.67	72	4.09	74	4.51	77	4.93	83	5.83	91	6.95	61	10.04	64	11.06	72	13.46	85	16.05			41	23.45	43	25.54
16203	1100	76	4.03	79	4.50	82	4.96	84	5.42	91	6.41	100	7.65	67	11.04	71	12.16	79	14.80	94	17.65			45	25.79	47	28.10
17676	1200	83	4.40	86	4.91	89	5.42	92	5.92	99	6.99	70	10.98	73	12.05	77	13.27	86	16.15	47	25.92			49	28.14	51	30.65
19149	1300	90	4.77	93	5.32	96	5.87	100	6.41	73	10.80	76	11.90	80	13.05	83	14.38	94	17.49	51	28.09			53	30.48	56	33.21
20622	1400	97	5.13	73	9.26	74	9.85	76	10.43	79	11.63	82	12.81	86	14.05	90	15.48	53	27.84	55	30.25			58	32.83	60	35.76
22095	1500	77	9.31	78	9.93	80	10.55	81	11.18	85	12.46	88	13.73	92	15.06	96	16.59	57	29.83	59	32.41			62	35.17	64	38.32
23568	1600	82	9.93	83	10.59	85	11.26	87	11.92	90	13.29	94	14.64	98	16.06	61	31.82	63	34.57	66	37.52			69	40.87		
26514	1800	92	11.17	94	11.91	95	12.66	97	13.41	63	28.19	64	29.70	65	31.22	66	32.75	69	35.79	71	38.89			74	42.20	77	45.98
29460	2000	67	27.19	67	28.01	68	28.83	69	29.66	70	31.32	71	32.99	72	34.68	74	36.39	76	39.77	79	43.21			82	46.89	86	51.09
32406	2200	74	29.91	74	30.81	75	31.71	76	32.62	77	34.46	78	36.29	80	38.15	81	40.02	84	43.75	87	47.53			90	51.58	94	56.20

LEGEND 870 RPM=Bold Face 1160 RPM=Normal Face 1750 RPM=Bold Italic Face

Size 39 CDD Direct Drive Centaxial – Partial Width Wheels

Wheel Diameter: 39.37"

Inlet Diameter: 59.06"

Inlet/Outlet Area: 19.02 ft.²

Tip Speed FPM = 10.31 x Fan RPM

Max. BHP = 20.5 (RPM ÷ 1000)³ x % of Wheel Width

CFM	OV	0.25" SP		0.5" SP		0.75" SP		1" SP		1.5" SP		2" SP		2.5" SP		3" SP		4" SP		5" SP		6" SP		7" SP			
		PW	BHP	PW	BHP	PW	BHP	PW	BHP	PW	BHP	PW	BHP	PW	BHP	PW	BHP	PW	BHP	PW	BHP	PW	BHP	PW	BHP		
9510	500	32	2.86	33	3.13	34	3.41	35	3.68	37	4.23	40	4.84	43	5.59	47	6.38	31	9.24	34	10.82			39	12.47		
11412	600	39	3.44	40	3.76	41	4.09	42	4.41	45	5.07	48	5.81	52	6.71	57	7.66	37	11.09	41	12.99			47	14.96		
13314	700	45	4.01	46	4.39	48	4.77	49	5.15	52	5.92	56	6.78	60	7.83	66	8.93	43	12.94	48	15.15			55	17.45		
15216	800	52	4.58	53	5.01	55	5.45	56	5.88	60	6.76	64	7.75	69	8.95	76	10.21	50	14.79	55	17.31			62	19.94		
17118	900	58	5.15	60	5.64	61	6.13	63	6.62	67	7.61	72	8.72	77	10.06	85	11.49	56	16.64	61	19.48			70	22.44		
19020	1000	65	5.73	66	6.27	68	6.81	70	7.36	75	8.45	80	9.68	86	11.18	95	12.76	62	18.49	68	21.64			78	24.93		
20922	1100	71	6.30	73	6.89	75	7.49	77	8.09	82	9.30	88	10.65	95	12.30	63	17.39	68	20.34	75	23.81			86	27.42		
22824	1200	77	6.87	80	7.52	82	8.17	84	8.83	89	10.15	95	11.62	66	17.59	69	18.97	74	22.19	82	25.97			94	29.92		
24726	1300	84	7.44	86	8.15	89	8.85	91	9.56	97	10.99	70	17.63	72	19.06	74	20.55	80	24.04	89	28.13						
26628	1400	90	8.02	93	8.77	96	9.53	98	10.30	73	17.45	75	18.99	77	20.52	80	22.13	87	25.89	96	30.30						
28530	1500	97	8.59	100	9.40	74	16.26	75	17.07	78	18.70	80	20.35	83	21.99	86	23.71	93	27.73								
30432	1600	77	15.62	78	16.48	79	17.34	80	18.20	83	19.94	86	21.70	88	23.45	92	25.29	99	29.58								
34236	1800	86	17.58	87	18.54	89	19.51	90	20.48	93	22.44	96	24.42	100	26.38												
38040	2000	96	19.53	97	20.60	99	21.67																				

LEGEND 870 RPM=Bold Face 1160 RPM=Normal Face

Size 44 CDD Direct Drive Centaxial – Partial Width Wheels

Wheel Diameter: 44.09"

Inlet Diameter: 64.97"

Inlet/Outlet Area: 23.02 ft.²

Tip Speed FPM = 11.54 x Fan RPM

Max. BHP = 36.2 (RPM ÷ 1000)³ x % of Wheel Width

CFM	OV	0.25" SP		0.5" SP		0.75" SP		1" SP		1.5" SP		2" SP		2.5" SP		3" SP		4" SP		5" SP		6" SP		7" SP	
		PW	BHP	PW	BHP	PW	BHP	PW	BHP	PW	BHP	PW	BHP	PW	BHP	PW	BHP	PW	BHP	PW	BHP	PW	BHP	PW	BHP
11510	500	28	4.26	28	4.59	29	4.91	30	5.24	31	5.91	33	6.58	34	7.33	36	8.23	43	10.15	27	14.00			29	

Dimensional Data – CBD Inline

Type C

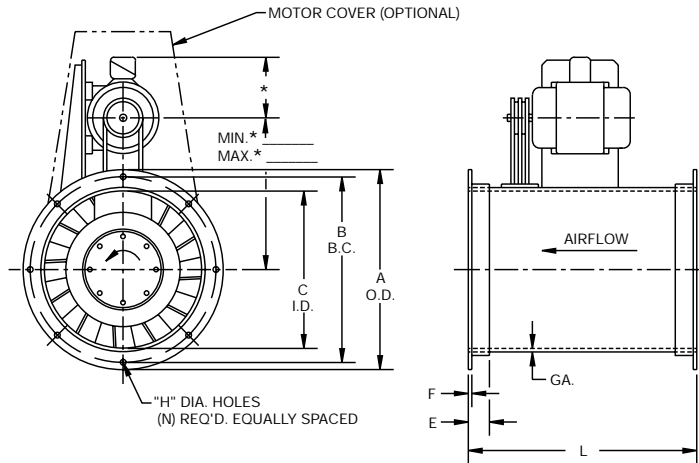

*These dimensions are dependent on the motor used.

SIZE (IN.)	OUTLET AREA (SQ. FT.)	WHEEL DIA. (IN.)	DIMENSIONS (IN.)								GA	MAX. MOTOR FRAME
			A	B	C	E	F	H	L	N		
12	1.91	12.40	21 ⁷ / ₈	20 ¹ / ₂	18 ¹¹ / ₁₆	1 ¹ / ₂	3 ³ / ₁₆	7 ¹ / ₁₆	22 ¹ / ₂	8	14	184T
14	2.37	13.98	24 ¹ / ₃₂	22 ²¹ / ₃₂	20 ⁷ / ₈	1 ¹ / ₂	3 ³ / ₁₆	7 ¹ / ₁₆	25	16	14	215T
16	3.04	15.75	26 ²⁵ / ₃₂	25 ¹³ / ₃₂	23 ⁵ / ₈	1 ¹ / ₂	3 ³ / ₁₆	7 ¹ / ₁₆	28	16	14	256T
18	3.79	17.72	29 ¹⁷ / ₃₂	28 ⁵ / ₃₂	26 ³ / ₈	1 ¹ / ₂	3 ³ / ₁₆	7 ¹ / ₁₆	32 ¹ / ₂	16	14	256T
20	4.76	19.68	32 ¹¹ / ₁₆	31 ³ / ₈	29 ¹⁷ / ₃₂	1 ¹ / ₂	3 ³ / ₁₆	9 ¹ / ₁₆	36	16	14	286T
22	6.11	22.05	36 ⁵ / ₈	35 ⁵ / ₁₆	33 ¹⁵ / ₃₂	1 ¹ / ₂	3 ³ / ₁₆	9 ¹ / ₁₆	39 ¹ / ₂	16	14	286T
25	7.63	24.80	41 ¹⁹ / ₃₂	39 ²⁵ / ₃₂	37 ¹³ / ₃₂	2	1 ¹ / ₄	9 ¹ / ₁₆	44	16	12	286T
28	9.50	27.95	45 ¹⁵ / ₁₆	44 ¹ / ₈	41 ²³ / ₃₂	2	1 ¹ / ₄	9 ¹ / ₁₆	50	16	12	326T
32	11.78	31.50	50 ²¹ / ₃₂	48 ²⁷ / ₃₂	46 ¹⁵ / ₃₂	2	1 ¹ / ₄	9 ¹ / ₁₆	55 ¹ / ₂	24	12	326T
35	14.73	35.43	56 ⁵ / ₃₂	54 ¹³ / ₃₂	51 ³¹ / ₃₂	2	1 ¹ / ₄	9 ¹ / ₁₆	62	24	12	365T
39	19.02	39.37	63 ³ / ₄	61 ¹ / ₂	59 ¹ / ₁₆	2	1 ¹ / ₄	9 ¹ / ₁₆	69	24	12	365T
44	23.02	44.09	69 ¹ / ₄	67 ¹ / ₂	64 ³¹ / ₃₂	2	1 ¹ / ₄	9 ¹ / ₁₆	76 ¹ / ₂	24	10	405T
49	28.93	49.21	77 ¹ / ₈	75 ³ / ₈	72 ²⁷ / ₃₂	2	1 ¹ / ₄	11 ¹ / ₁₆	85	32	10	405T
55	35.88	55.12	87 ³ / ₈	84 ¹¹ / ₁₆	81 ³ / ₃₂	3	5 ¹ / ₁₆	11 ¹ / ₁₆	95 ¹ / ₂	32	10	405T
63	47.08	62.99	99 ³ / ₁₆	96 ¹ / ₂	92 ²⁹ / ₃₂	3	5 ⁵ / ₁₆	11 ¹ / ₁₆	109 ¹ / ₂	32	10	405T
71	59.37	70.86	110 ¹⁹ / ₃₂	107 ²⁹ / ₃₂	104 ¹¹ / ₃₂	3	5 ⁵ / ₁₆	11 ¹ / ₁₆	122	32	10	405T

All figures are in inches unless otherwise noted.

Dimensions are not to be used for construction.

Type TC

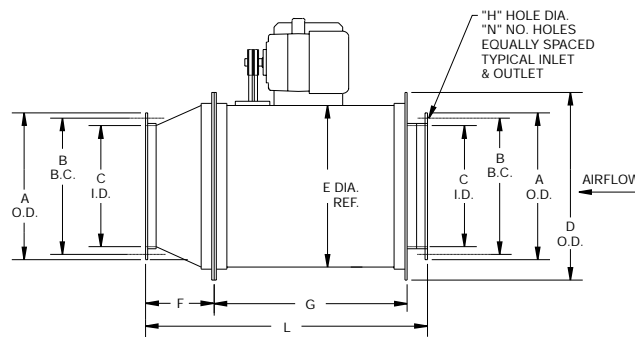

SIZE	A	B	C	D	E	F	G	H	L	N
12	17 ¹ / ₈	15 ⁷ / ₈	14 ¹ / ₈	21 ⁷ / ₈	18 ²⁷ / ₃₂	8	22 ¹ / ₂	5 ¹ / ₁₆	32 ⁷ / ₈	8
14	18 ²⁹ / ₃₂	17 ⁷ / ₈	15 ²⁹ / ₃₂	24 ¹ / ₃₂	21 ¹ / ₃₂	8 ⁵ / ₈	25	9 ¹ / ₁₆	36	8
16	20 ⁷ / ₈	19 ¹⁹ / ₃₂	17 ⁷ / ₈	26 ²⁵ / ₃₂	23 ²⁵ / ₃₂	9 ³ / ₈	28	7 ¹ / ₁₆	42 ¹ / ₈	8
18	22 ²⁷ / ₃₂	21 ⁹ / ₁₆	19 ²⁷ / ₃₂	29 ¹⁷ / ₃₂	26 ¹⁷ / ₃₂	10 ¹ / ₈	32 ¹ / ₂	7 ¹ / ₁₆	47 ³ / ₈	16
20	25 ³ / ₁₆	23 ¹⁵ / ₁₆	22 ³ / ₁₆	32 ¹¹ / ₁₆	29 ¹¹ / ₁₆	10 ⁷ / ₈	36	7 ¹ / ₁₆	51 ⁵ / ₈	16
22	27 ³¹ / ₃₂	26 ¹¹ / ₁₆	24 ³¹ / ₃₂	36 ⁵ / ₈	33 ⁵ / ₈	11 ⁷ / ₈	39 ¹ / ₂	7 ¹ / ₁₆	56 ¹ / ₈	16
25	31 ¹ / ₈	29 ²⁷ / ₃₂	28 ¹ / ₈	41 ¹⁹ / ₃₂	37 ⁵ / ₈	13 ¹ / ₂	44	7 ¹ / ₁₆	62 ¹ / ₄	16
28	34 ²¹ / ₃₂	33 ³ / ₈	31 ²¹ / ₃₂	45 ¹⁵ / ₁₆	41 ¹⁵ / ₁₆	14 ³ / ₄	50	9 ¹ / ₁₆	69 ¹ / ₂	16
32	39 ¹⁹ / ₃₂	37 ²⁷ / ₃₂	35 ¹⁹ / ₃₂	50 ²¹ / ₃₂	46 ¹¹ / ₁₆	16 ⁵ / ₈	55 ¹ / ₂	9 ¹ / ₁₆	77 ³ / ₄	16
35	43 ¹⁷ / ₃₂	41 ²⁵ / ₃₂	39 ¹⁷ / ₃₂	56 ⁵ / ₃₂	52 ³ / ₁₆	18 ¹ / ₄	62	9 ¹ / ₁₆	85 ⁷ / ₈	16
39	48 ⁵ / ₁₆	46 ¹⁷ / ₃₂	44 ⁵ / ₁₆	63 ³ / ₄	59 ⁹ / ₃₂	19 ³ / ₄	69	9 ¹ / ₁₆	94 ³ / ₈	24
44	53 ¹³ / ₃₂	51 ²¹ / ₃₂	49 ¹³ / ₃₂	69 ¹ / ₄	65 ¹ / ₄	21 ⁵ / ₈	76 ¹ / ₂	9 ¹ / ₁₆	103 ³ / ₄	24
49	59 ⁹ / ₁₆	57 ⁹ / ₁₆	55 ⁹ / ₁₆	77 ¹ / ₈	73 ¹ / ₈	23 ³ / ₄	85	9 ¹ / ₁₆	114 ³ / ₈	24
55	67 ⁹ / ₃₂	65 ¹ / ₂	63 ⁹ / ₃₂	87 ³ / ₈	81 ³ / ₈	27 ¹ / ₈	95 ¹ / ₂	9 ¹ / ₁₆	126	24
63	75 ⁵ / ₃₂	73 ³ / ₈	71 ⁵ / ₃₂	99 ³ / ₁₆	93 ³ / ₁₆	30 ¹ / ₄	109 ¹ / ₂	11 ¹ / ₁₆	143 ¹ / ₈	32
71	85	82 ¹ / ₂	79	110 ¹⁹ / ₃₂	104 ⁵ / ₈	34 ³ / ₈	122	11 ¹ / ₁₆	161 ³ / ₄	32

All figures are in inches unless otherwise noted.

Dimensions are not to be used for construction.

Dimensional Data – CBD Roof Ventilator

Roof Ventilator

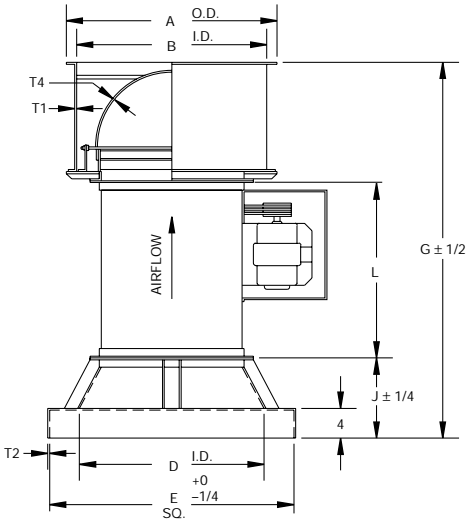

SIZE (IN.)	DIMENSIONS							STEEL (GAUGE)				ALUMINUM (THICKNESS)		
	A	B	D	E	G	J	L	T1	T2	T3	T4	T1	T2/T3	T4
12	28 ³ / ₄	25 ³ / ₈	24 ³ / ₄	32 ³ / ₄	55	10 ³ / ₄	22 ¹ / ₂	14	12	14	24	.050	.100	.032
14	29 ³ / ₄	26 ⁷ / ₈	24 ³ / ₄	32 ³ / ₄	57 ³ / ₄	9	25	14	12	14	24	.050	.100	.032
16	31 ³ / ₄	28 ⁷ / ₈	27 ³ / ₄	35 ³ / ₄	61 ³ / ₄	9	28	14	12	14	24	.050	.100	.032
18	35 ³ / ₄	32 ⁷ / ₈	35 ³ / ₄	43 ³ / ₄	72 ³ / ₄	13 ¹ / ₂	32 ¹ / ₂	14	12	14	24	.050	.100	.032
20	39 ³ / ₄	36 ⁷ / ₈	35 ³ / ₄	43 ³ / ₄	74 ³ / ₄	11	36	14	12	14	20	.080	.100	.050
22	41 ³ / ₄	38 ⁷ / ₈	41 ³ / ₄	49 ³ / ₄	81	12 ³ / ₄	39 ¹ / ₂	14	12	14	20	.080	.100	.050
25	45 ³ / ₄	42 ⁷ / ₈	41 ³ / ₄	49 ³ / ₄	84 ¹ / ₂	9 ³ / ₄	44	14	12	14	20	.080	.100	.050
28	51 ³ / ₄	48 ⁷ / ₈	47 ³ / ₄	55 ³ / ₄	95	11 ¹ / ₄	50	14	12	12	20	.080	.125	.050
32	57 ³ / ₄	54 ⁷ / ₈	53 ³ / ₄	61 ³ / ₄	104 ¹ / ₂	12 ¹ / ₄	55 ¹ / ₂	14	10	12	20	.080	.125	.050
35	64	60 ³ / ₄	59 ³ / ₄	67 ³ / ₄	114 ¹ / ₂	12 ³ / ₄	62	14	10	12	20	.080	.125	.080
39	70	66 ³ / ₄	66 ³ / ₄	74 ³ / ₄	125 ¹ / ₂	12 ³ / ₄	69	14	10	12	20	.125	.125	.080
44	74	70 ³ / ₄	80 ³ / ₄	88 ³ / ₄	140	19 ³ / ₄	76 ¹ / ₂	14	10	10	20	.125	.125	.080
49	88	84 ³ / ₄	80 ³ / ₄	88 ³ / ₄	147 ¹ / ₂	12 ³ / ₄	85	14	10	10	20	.125	.125	.080
55	100	96 ³ / ₄	92 ³ / ₄	100 ³ / ₄	169 ¹ / ₂	17	95 ¹ / ₂	14	10	10	20	.125	.125	.080
63	103	99 ³ / ₄	104 ³ / ₄	112 ³ / ₄	190 ¹ / ₂	17 ¹ / ₄	109 ¹ / ₂	14	10	10	20	.125	.160	.080
71	112	108 ³ / ₄	112 ³ / ₄	120 ³ / ₄	203	14 ¹ / ₄	122	14	10	10	20	.125	.160	.080

All figures are in inches unless otherwise noted.
Dimensions are not to be used for construction.

Minimum Outlet Velocity Required For Full Open Damper Operation:

Steel Dampers – 1700 FPM
Aluminum Dampers – 1300 FPM

Fume Hood Exhauster

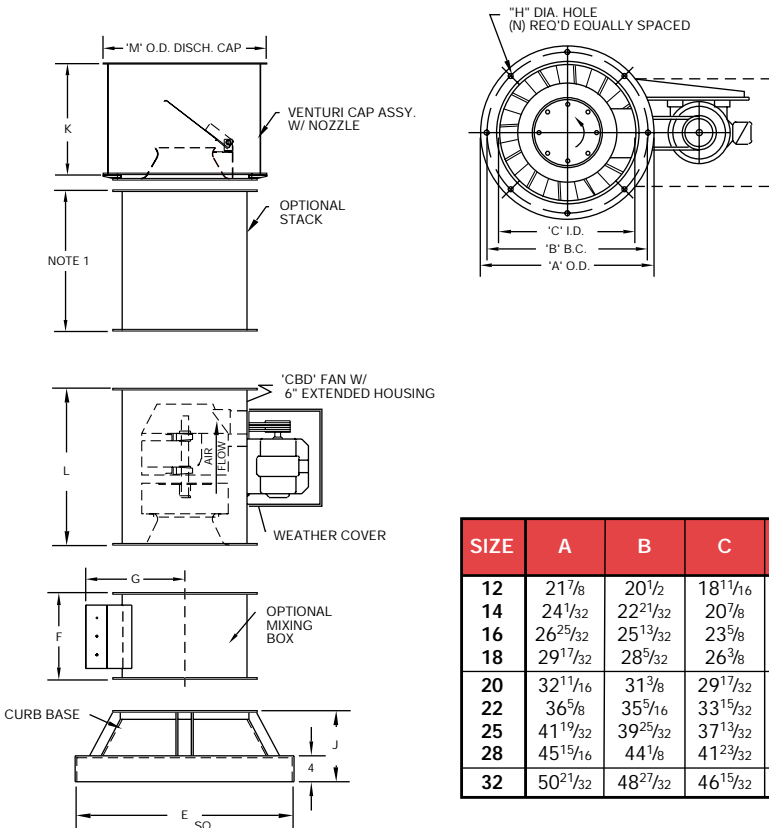

AVAILABLE NOZZLE SIZES																
SIZE	6	7	8	10	11	12	13	15	16	18	20	22	24	27	30	33
12	X	X	X	X	X	X	X									
14				X	X	X	X	X	X							
16				X	X	X	X	X	X	X						
18				X	X	X	X	X	X	X	X					
20						X	X	X	X	X	X	X				
22								X	X	X	X	X	X			
25											X	X	X	X		
28												X	X	X	X	
32													X	X	X	X

SIZE	A	B	C	E	F	G	H	J	K	L	M	N
12	21 ⁷ / ₈	20 ¹ / ₂	18 ¹ / ₁₆	32 ³ / ₄	16 ¹ / ₂	19 ¹ / ₂	7 ¹ / ₁₆	10 ³ / ₄	19 ¹ / ₄	28 ¹ / ₂	29	8
14	24 ¹ / ₃₂	22 ¹ / ₃₂	20 ⁷ / ₈	32 ³ / ₄	23 ¹ / ₂	20 ¹ / ₂	7 ¹ / ₁₆	9	22 ¹ / ₂	31	33	16
16	26 ²⁹ / ₃₂	25 ¹³ / ₃₂	23 ⁵ / ₈	35 ³ / ₄	23 ¹ / ₂	21 ⁷ / ₈	7 ¹ / ₁₆	9	24 ¹ / ₂	34	36	16
18	29 ¹⁷ / ₃₂	28 ⁵ / ₃₂	26 ³ / ₈	43 ³ / ₄	28	23 ¹ / ₄	7 ¹ / ₁₆	13 ¹ / ₂	27	38 ¹ / ₂	37	16
20	32 ¹¹ / ₁₆	31 ³ / ₈	29 ¹⁷ / ₃₂	43 ³ / ₄	30 ¹ / ₂	24 ⁷ / ₈	9 ¹ / ₁₆	11	29 ¹ / ₂	42	40	16
22	36 ⁵ / ₈	35 ⁵ / ₁₆	33 ¹⁵ / ₃₂	49 ³ / ₄	33 ¹ / ₂	26 ⁷ / ₈	9 ¹ / ₁₆	12 ³ / ₄	32 ¹ / ₂	45 ¹ / ₂	43	16
25	41 ¹⁹ / ₃₂	39 ²⁹ / ₃₂	37 ¹³ / ₃₂	49 ³ / ₄	36 ¹ / ₂	28 ⁷ / ₈	9 ¹ / ₁₆	9 ³ / ₄	35 ¹ / ₂	50	46	16
28	45 ¹⁵ / ₁₆	44 ¹ / ₈	41 ²³ / ₃₂	55 ³ / ₄	40	31	9 ¹ / ₁₆	11 ¹ / ₄	38 ³ / ₄	56	50	16
32	50 ²¹ / ₃₂	48 ²⁷ / ₃₂	46 ¹⁵ / ₃₂	61 ³ / ₄	45	33 ¹ / ₂	9 ¹ / ₁₆	12 ¹ / ₄	42 ¹ / ₂	61 ¹ / ₂	53	24

NOTES:

1. Optional stack length will vary in length to make overall height 10' tall.

Dimensional Data – CDD Inline

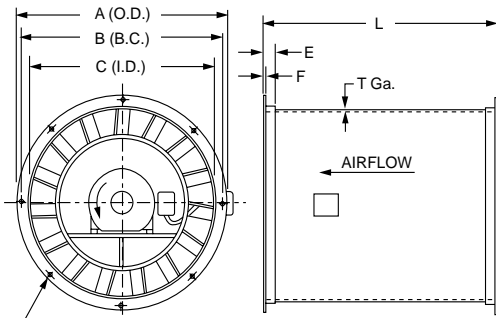

16 Holes Equally Spaced (Sizes 14–28)
 8 Holes Equally Spaced (Size 12)
 24 Holes Equally Spaced (Sizes 32–44)
 "H" Dia. Hole

SIZE	MAX. MOTOR FRAME	WHEEL DIA. (IN.)	OUTLET AREA (FT ²)	A	B	C	E	F	H	L	T
12	145T	12 ³ / ₃₂	1.91	21 ⁷ / ₈	20 ¹ / ₂	18 ¹ / ₁₆	–	12 GA.	⁹ / ₁₆	23	12 GA.
14	184T	14	2.37	24 ¹ / ₃₂	22 ² / ₃₂	20 ⁷ / ₈	–	12 GA.	⁹ / ₁₆	26	12 GA.
16	215T	15 ³ / ₄	3.04	26 ² / ₃₂	25 ¹ / ₃₂	23 ³ / ₈	–	12 GA.	⁹ / ₁₆	29	12 GA.
18	254T	17 ² / ₃₂	3.79	29 ¹ / ₃₂	28 ⁵ / ₃₂	26 ³ / ₈	–	12 GA.	⁹ / ₁₆	34	12 GA.
20	184T	19 ¹ / ₁₆	4.76	32 ¹ / ₁₆	31 ³ / ₈	29 ¹ / ₃₂	–	12 GA.	⁹ / ₁₆	30	12 GA.
22	184T	22 ¹ / ₁₆	6.11	36 ⁵ / ₈	35 ⁵ / ₁₆	33 ⁵ / ₃₂	–	12 GA.	⁹ / ₁₆	31	12 GA.
25	215T	24 ¹ / ₃₂	7.63	41 ¹ / ₃₂	39 ² / ₃₂	37 ¹ / ₃₂	–	10 GA.	⁹ / ₁₆	35	10 GA.
28	254T	27 ³ / ₃₂	9.50	45 ⁵ / ₁₆	44 ¹ / ₈	41 ² / ₃₂	–	10 GA.	¹¹ / ₁₆	40	10 GA.
32	286T	31 ¹ / ₂	11.78	50 ² / ₃₂	48 ² / ₃₂	46 ¹ / ₃₂	–	10 GA.	¹¹ / ₁₆	48	10 GA.
35	326T	35 ⁷ / ₁₆	14.73	56 ⁵ / ₃₂	54 ¹ / ₃₂	51 ¹ / ₃₂	–	7 GA.	¹¹ / ₁₆	53	7 GA.
39	326T	39 ³ / ₈	19.02	63 ¹ / ₄	61 ¹ / ₂	59 ¹ / ₁₆	2	¹ / ₄	¹¹ / ₁₆	56	12 GA.
44	365T	44 ³ / ₃₂	23.02	69 ¹ / ₄	67 ¹ / ₂	64 ³ / ₃₂	2	¹ / ₄	¹¹ / ₁₆	62	10 GA.

Dimensions are in inches unless otherwise indicated.
 Dimensions are not to be used for construction.

Support Legs – Floor or Ceiling Hung

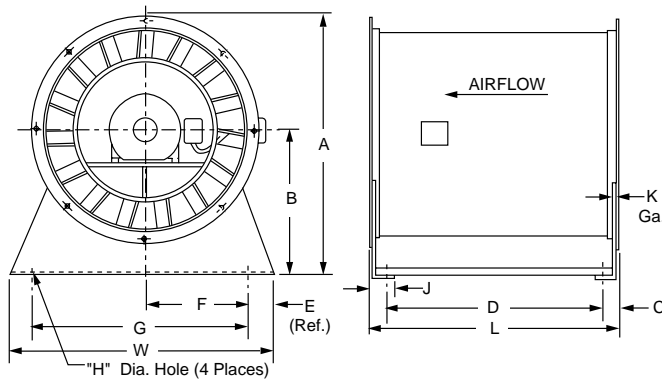

SIZE	A	B	C	D	E	F	G	H	J	L	W	K Ga.
12	26 ¹ / ₁₆	15 ¹ / ₈	⁷ / ₈	21 ¹ / ₄	³ / ₄	10 ¹ / ₄	20 ¹ / ₂	⁹ / ₁₆	1 ¹¹ / ₁₆	23	22	10
14	28 ¹ / ₁₆	16 ¹ / ₁₆	⁷ / ₈	24 ¹ / ₄	³ / ₄	11 ¹ / ₄	22 ¹ / ₂	⁹ / ₁₆	1 ¹¹ / ₁₆	26	24	10
16	31 ¹ / ₁₆	17 ¹ / ₁₆	1 ¹ / ₈	26 ³ / ₄	1	12 ¹ / ₂	25	⁹ / ₁₆	2 ³ / ₁₆	29	27	10
18	34 ¹ / ₁₆	19 ⁵ / ₁₆	1 ³ / ₄	30 ¹ / ₂	1 ¹ / ₂	13 ¹ / ₂	27	⁹ / ₁₆	3 ³ / ₁₆	34	30	10
20	37 ³ / ₁₆	20 ² / ₃₂	1 ³ / ₄	26 ¹ / ₂	1 ¹ / ₂	15	30	⁹ / ₁₆	3 ³ / ₁₆	30	33	7
22	41 ³ / ₁₆	22 ⁷ / ₈	1 ³ / ₄	27 ¹ / ₂	1 ¹ / ₂	17	34	⁹ / ₁₆	3 ³ / ₁₆	31	37	7
25	46 ¹ / ₄	25 ¹ / ₁₆	1 ³ / ₄	31 ¹ / ₂	1 ¹ / ₂	19 ¹ / ₂	39	⁹ / ₁₆	3 ¹ / ₄	35	42	7
28	50 ¹ / ₄	27 ³ / ₃₂	1 ³ / ₄	36 ¹ / ₂	1 ¹ / ₂	21 ¹ / ₂	43	⁹ / ₁₆	3 ¹ / ₄	40	46	7
32	54 ¹ / ₁₆	29 ¹ / ₂	1 ³ / ₄	44 ¹ / ₂	1 ¹ / ₂	24	48	⁹ / ₁₆	3 ¹ / ₄	48	51	7
35	51 ¹ / ₄	33 ³ / ₁₆	1 ³ / ₄	49 ¹ / ₂	1 ¹ / ₂	26 ¹ / ₂	53	⁹ / ₁₆	3 ¹ / ₄	53	56	7
39	68 ¹ / ₄	36 ⁵ / ₈	2 ¹ / ₄	51 ¹ / ₂	2	29 ¹ / ₂	59	⁹ / ₁₆	4 ¹ / ₄	56	63	7
44	74 ¹ / ₄	39 ⁵ / ₈	2 ¹ / ₄	57 ¹ / ₂	2	32 ¹ / ₂	65	⁹ / ₁₆	4 ¹ / ₄	62	69	7

Dimensions are in inches unless otherwise indicated.
 Dimensions are not to be used for construction.

NOTE: Totally enclosed air-over motors are not available due to insufficient flow of air over motor needed for proper cooling.

Mounting Positions

Vertical Discharge Positions

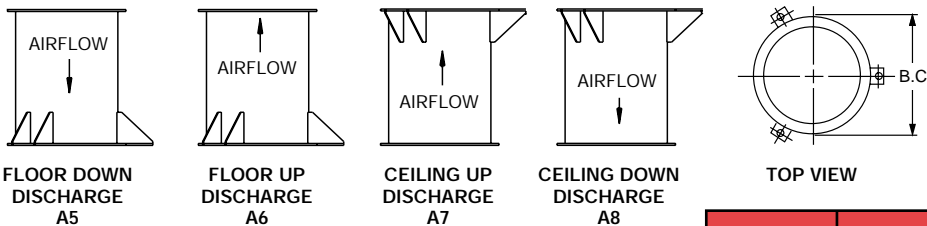

MOUNTING PAD SIZE
 7 GA for sizes 12 through 22.
 1/4 PLT for sizes 25 and 28.
 All pads are 4" x 5".
 All pads have 1 1/16" diameter bolt holes.

NOTE: All sizes of the vertical discharge positions have three pads.

SIZE	A	B	B.C.	D
12	22 ⁷ / ₈	17 ⁵ / ₈	25 ² / ₃₂	2 ¹ / ₁₆
14	25 ¹ / ₈	20 ⁵ / ₈	28 ¹ / ₈	2 ¹ / ₁₆
16	27 ⁷ / ₈	23 ⁵ / ₈	30 ³ / ₄	2 ¹ / ₁₆
18	30 ⁵ / ₈	28 ⁵ / ₈	33 ¹ / ₃₂	2 ¹ / ₁₆
20	33 ³ / ₄	24 ⁵ / ₈	36 ¹ / ₁₆	2 ¹ / ₁₆
22	37 ⁵ / ₈	25 ⁵ / ₈	40 ² / ₃₂	2 ¹ / ₁₆
25	41 ⁵ / ₈	29 ¹ / ₂	45 ⁵ / ₈	2 ³ / ₄
28	46	34 ¹ / ₂	49 ¹ / ₁₆	2 ³ / ₄
32	50 ³ / ₄	42 ¹ / ₂	54 ¹ / ₁₆	2 ³ / ₄
35	56 ¹ / ₄	47 ¹ / ₂	60 ³ / ₁₆	2 ³ / ₄
39	63 ³ / ₈	50 ¹ / ₂	67 ¹ / ₄	2 ³ / ₄
44	69 ¹ / ₄	56 ¹ / ₂	73 ¹ / ₄	2 ³ / ₄

Dimensions are in inches unless otherwise indicated.
 Dimensions are not to be used for construction.

Ceiling Horizontal Discharge Position – A13

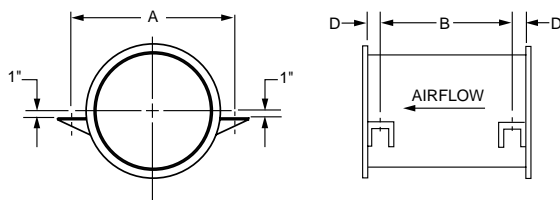

NOTE: All sizes of the ceiling horizontal discharge position have four pads.

Typical Specifications – CBD

Fans shall be of the Belt Driven, Backward Inclined Airfoil, Centaxial® (Tubular Inline Centrifugal) type, as manufactured by Aerovent, Minneapolis, Minnesota, and shall be of the size and capacity as indicated in the fan schedule. Fans shall be tested in accordance with ANSI/ASHRAE 51-1985 and ANSI/AMCA 210-85 test codes and guaranteed by the manufacturer to deliver at the rated published performance levels. In addition, each unit shall be factory run tested prior to shipment.

HOUSINGS — Housings shall be designed to meet Class I/Class II/Class III construction. Housings shall be constructed of heavy-gauge rolled steel with continuous seam type welding, angle ring flanges, and side angle reinforcement. The inner shell and guide vanes shall be integrally welded with the outer fan casing providing a substantial weldment. The inlet funnel shall be built into the fan casing to provide optimal airflow into the fan wheel. Flanges at the inlet and outlet of the fan casing are to be the same size for easy mounting of the fan into the ductwork. An adjustable motor base plate assembly shall be welded to the outside of the fan housing to provide belt tension adjustment. Housing material shall be constructed of the following optional metal:

- Steel Aluminum Stainless Steel 316 Stainless Steel

WHEELS — Wheels shall be statically and dynamically balanced and shall be attached to the shaft with a split taper lock bushing. Some larger wheels are furnished with straight bore hubs. The blades on the BIA wheel shall be backward curved, double thickness airfoil type, continuously welded to a flat wheel cone and back plate. BIA wheel sizes 12 through 25 shall be constructed from heavy gauge aluminum only. BIA sizes 28 and larger shall have wheels that are constructed from heavy gauge steel with aluminum as an option.

BEARINGS — Bearings shall be pillow block design, oversized to ensure maximum bearing life and shall have a minimum L-10 life as defined by AFBMA of at least 40,000 hours (200,000 hours average life).

DRIVES — The V-belt drive package shall consist of cast iron sheaves and static conducting belts. The bearings and belts shall be enclosed in an air insulated housing for protection. The belts and sheaves furnished by the manufacturer shall be selected to provide a minimum 1.4 service factor when measured against motor horsepower.

MOTORS — Fan motors shall be foot mounted NEMA Design B, standard industrial, continuous duty ball bearing variable torque type suitable for operation on voltage, phase and hertz, as listed in the fan schedule. Motor bearings shall have a minimum L-10 life, as defined by AFBMA, of at least 40,000 hours (200,000 hours average life).

BALANCING — The propeller assembly shall be statically and dynamically balanced in accordance with ANSI / AMCA 204-96 “Balance Quality and Vibration Levels for Fans” to Fan Application Category BV-3, Balance Quality Grade G6.3. In addition, belt driven fan propellers shall be balanced on the fan shaft after final assembly in the fan casing, in the manufacturing facility, to the following peak velocity values, filter-in, at the fan test speed:

Fan Application Category	Rigidly Mounted (in./s)	Flexibly Mounted (in./s)
BV-3	0.15	0.20

FINISH — The unit, after fabrication, shall be cleaned and chemically pretreated by a phosphatizing process and shall be painted inside and outside with an alkyd primer and finish painted with an air dry acrylic enamel. Fan shall be coated with the following optional finish:

- | | | |
|--|--|--------------------------------------|
| <input type="checkbox"/> Air Dry Epoxy | <input type="checkbox"/> Asphalt Based Coating | <input type="checkbox"/> Galvanizing |
| <input type="checkbox"/> High Temperature Aluminum | <input type="checkbox"/> Carbolene 3358/Sanitile 550 | <input type="checkbox"/> Quaker Koat |
| Carbolene Primer/Sanitile Finish | | |

The following coatings require a sandblast metal preparation before applying:

- | | | |
|---|--|---|
| <input type="checkbox"/> Plasite 4310-Vinyl Ester | <input type="checkbox"/> Heresite VR506-Air Dry Epoxy Phenolic | <input type="checkbox"/> Plasite 3066-Baked Phenolic |
| <input type="checkbox"/> Plasite 7122L-Air Dry Epoxy Phenolic | <input type="checkbox"/> Plasite 1246-Baked Epoxy Phenolic | <input type="checkbox"/> Farboil-Baked Aromatic Epoxy |

ACCESSORIES — The units shall be furnished complete with:

- | | |
|---|---|
| <input type="checkbox"/> OSHA Type Inlet Guard | <input type="checkbox"/> Spark Resistant Construction (Type A, B, C) |
| <input type="checkbox"/> OSHA Type Outlet Guard | <input type="checkbox"/> High Temperature Construction |
| <input type="checkbox"/> Acoustical Silencer | <input type="checkbox"/> Type TC Companion Flanges (Steel/Aluminum/Stainless Steel) |
| <input type="checkbox"/> Wheel Inspection Door | <input type="checkbox"/> Elastomeric Shaft Seal |
| <input type="checkbox"/> Access Door | <input type="checkbox"/> OSHA Type Motor Cover |
| <input type="checkbox"/> Manually Operated Inlet Vortex Damper | <input type="checkbox"/> OSHA Type Belt Guard |
| <input type="checkbox"/> Ceiling Vibration Isolators (RIS/Spring) | <input type="checkbox"/> Optional BI Wheel |
| <input type="checkbox"/> Floor Vibration Isolators (RIS/Spring) | <input type="checkbox"/> Stack Cap |
| <input type="checkbox"/> Support Legs | <input type="checkbox"/> Curb Base |
| <input type="checkbox"/> Horizontal Ceiling Mounting Brackets | |
| <input type="checkbox"/> Vertical Mounting Brackets | |

Typical Specifications – CDD

Fans shall be of the CDD Direct Drive Backward Inclined Airfoil Centaxial® (In-line Tubular Centrifugal) type, as manufactured by Aerovent, Minneapolis, Minnesota, and shall be of the size and capacity as indicated in the fan schedule. Centaxial® fans shall be tested in accordance with ANSI/ASHRAE 51-1985 and ANSI/AMCA 210-85 test codes and guaranteed by the manufacturer to deliver at the rated published performance levels. In addition, each unit shall be factory run tested prior to shipment.

CONSTRUCTION — The fan casing shall be constructed of heavy-gauge rolled steel with continuous seam type welding and angle ring flanges. The guide vanes and motor base plate support shall be integrally welded with the outer fan casing providing a substantial weldment. The inlet funnel shall be built into the fan casing to provide optimal airflow into the fan wheel. Flanges at the inlet and outlet of the fan casing are to be the same size for easy mounting of the fan into ductwork. Housing material shall be constructed of the following optional metal:

- Steel Aluminum 304 Stainless Steel 316 Stainless Steel

WHEEL — The BIA wheel features continuously welded backward curved double thickness airfoil blades. Wheel sizes 12 through 25 shall be constructed from heavy gauge aluminum only. Sizes 28 and larger shall be furnished in heavy-gauge steel construction as standard with aluminum as an option. Blades shall be continuous and precision welded to flat wheel cones and staggered on each side of the center plate. The wheel shall be dynamically and statically balanced and shall be attached to the shaft with a split taper lock bushing or furnished with straight bore hubs.

MOTORS — Fan motors shall be foot mounted, NEMA Design B, standard industrial, continuous duty, ball bearing, variable torque type suitable for operation on voltage, phase and hertz, as listed in the fan schedule. Motor bearings shall have a minimum L-10 life, as defined by AFBMA, of at least 40,000 hours (200,000 hours average life). Units shall be supplied with motor wiring connections extended through liquid tight conduit to outside the fan housing. If motors have regreasable bearings, extended grease lines shall be supplied for lubrication of the motor bearings.

BALANCING — The wheel assembly shall be statically and dynamically balanced in accordance with ANSI/AMCA 204-96 “Balance Quality and Vibration Levels for Fans” to Fan Application Category BV-3, Balance Quality Grade G6.3. In addition, direct drive fan wheels shall be balanced on the fan shaft after final assembly in the fan casing, in the manufacturing facility, to the following peak velocity values, filter-in, at the fan test speed:

Fan Application Category	Rigidly Mounted (in./s)	Flexibly Mounted (in./s)
BV-3	0.15	0.20

FINISH — The unit, after fabrication, shall be cleaned and chemically pretreated by a phosphatizing process and shall be painted inside and outside with an air dry enamel. Fans shall be coated with the following optional finish:

- | | | |
|--|--|--------------------------------------|
| <input type="checkbox"/> Air Dry Epoxy | <input type="checkbox"/> Asphalt Based Coating | <input type="checkbox"/> Galvanizing |
| <input type="checkbox"/> High Temperature Aluminum | <input type="checkbox"/> Carbocoat 30 (Replaces Sanitile 550 and Eisenheiss 210) | <input type="checkbox"/> Quaker Koat |

The following coatings require a sandblast metal preparation before applying:

- | | | |
|---|--|---|
| <input type="checkbox"/> Plasite 4310-Vinyl Ester | <input type="checkbox"/> Heresite VR506-Air Dry Epoxy Phenolic | <input type="checkbox"/> Plasite 3066-Baked Phenolic |
| <input type="checkbox"/> Plasite 7122L-Air Dry Epoxy Phenolic | <input type="checkbox"/> Plasite 1246-Baked Epoxy Phenolic | <input type="checkbox"/> Farboil-Baked Aromatic Epoxy |

ACCESSORIES — The units shall be furnished complete with:

- | | |
|---|--|
| <input type="checkbox"/> OSHA Type Inlet or Outlet Guard | <input type="checkbox"/> Horizontal Ceiling Mounting Brackets |
| <input type="checkbox"/> Acoustical Silencer | <input type="checkbox"/> Vertical Mounting Brackets |
| <input type="checkbox"/> Wheel Inspection Door/Access Door | <input type="checkbox"/> Optional Construction Materials — Steel, Aluminum, 304 Stainless Steel, 316 Stainless Steel |
| <input type="checkbox"/> Manually Operated Inlet Vortex Damper | <input type="checkbox"/> Companion Flanges |
| <input type="checkbox"/> Ceiling Mounted Vibration Isolators (RIS/Spring) | <input type="checkbox"/> Ceiling Suspension Brackets |
| <input type="checkbox"/> Floor Mounted Vibration Isolators (RIS/Spring) | <input type="checkbox"/> Optional BI Wheel |
| <input type="checkbox"/> Support Legs | |