



***SMOKE AND HEAT REMOVAL
ROOF VENTILATOR***

Model SV40



Smoke and Heat Removal Roof Ventilator

The Model SV40 combines year-round powered ventilation with smoke and heat removal capabilities. This ventilator is designed to be used as a standard roof exhaust fan and a high temperature smoke and heat removal fan. It is a three-part assembly consisting of:

1. Stack cap damper assembly with fusible link kit
2. Curb base
3. High temperature, belt driven tubeaxial fan with a fabricated steel propeller

Standard Features

- Motor cover
- High temperature package
- Factory mounted and wired NEMA 3R non-fused disconnect switch
- Arrangement 9, vertical upblast discharge
- Available in sizes ranging from 24" to 60"
- Capacities to 70,000 CFM

The tall design of this ventilator is especially useful in the discharge of smoke and/or fumes high above the roof line and away from surrounding ventilation systems.

The three parts of the Model SV40 are shipped separately for ease of handling at the jobsite. Matching flanges on the fan, curb base and stack cap aid in field assembly of these components. Standard construction is of heavy-gauge steel finished with air-dried gray enamel.

If the fan fails to energize in an emergency situation, such as a fire, a thermally activated fusible link assembly will automatically open the stack cap damper and provide venting. The fusible link will retain a spring loaded actuator until the temperature melts the fusible link (160°F or 212°F), at which time the dampers open.

The Model SV40 features a fixed pitch, fabricated steel, 5-bladed propeller. Steel blades are continuously welded to a heavy gauge hub at the customer's selected blade angle.



*Steel Propeller
Welded Assembly*



Capabilities/Testing

The Model SV40 high temperature roof ventilator is designed specifically to comply with Industrial Risk Insurers' (IRI) recommendations for smoke and heat ventilation.

Unit testing was conducted at Aerovent's certified test lab using a 4 million BTU gas fired burner capable of generating airstream temperatures in excess of 1000°F. Airstream temperatures were precisely monitored using potentiometers with chromel-alumel thermocouples. Temperatures were monitored at several vital areas within the ventilator assembly: inlet side of the fan wheel, fan bearings, bearing housing, belt tube, and the motor compartment.

Based on this extensive testing, the Model SV40 is capable of withstanding continuous operation at 600°F, extended operating periods at 800°F and 8 hours or more with an airstream temperature of 1000°F.



Aerovent certifies that the Model SV40 Roof Ventilators shown herein are licensed to bear the AMCA Seal. The ratings shown are based on tests and procedures performed in accordance with AMCA Publication 211 and AMCA Publication 311 and comply with the requirements of the AMCA Certified Ratings Program.

©2004 Aerovent, Twin City Fan Companies, Ltd.

Bulletin illustrations cover the general appearance of Aerovent products at the time of publication and we reserve the right to make changes in design and construction at any time without notice.

Stack Cap Features

(Windband not shown for clarity reasons)

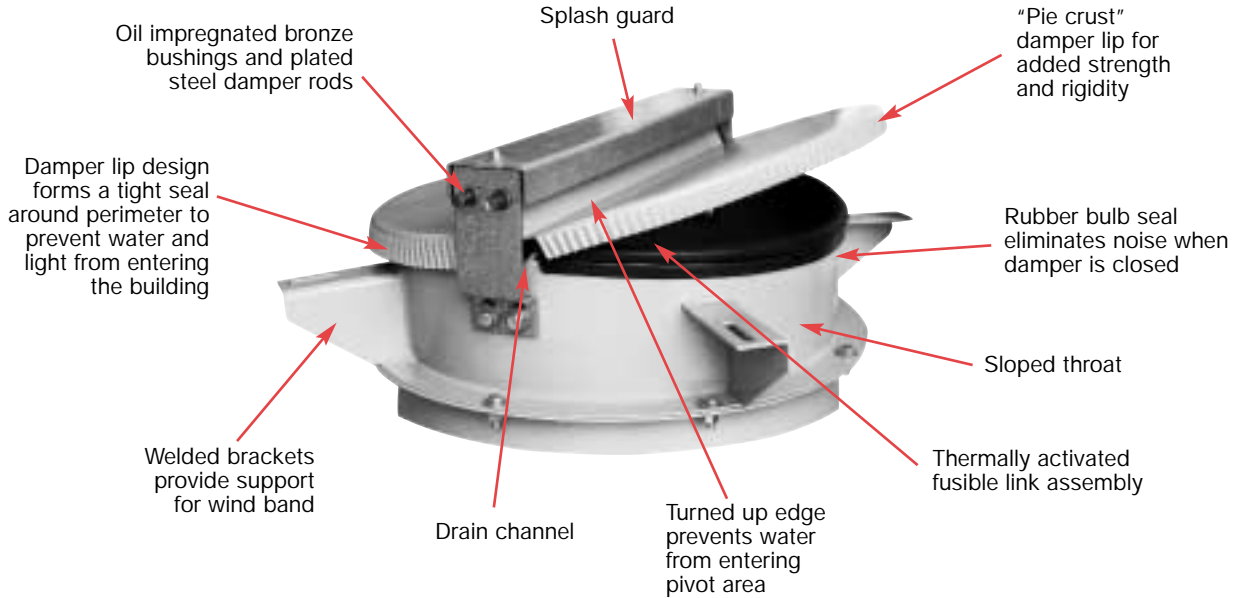

Application

The application of smoke and heat venting requires special considerations. In some applications, the mechanical exhaust fans may be used to provide up to one-half of the venting requirements. However, in trapped and low hazard areas where smoke may be the primary concern, the mechanical exhaust fans may provide all of the venting. The minimum fan capacity where all mechanical venting is used must be the same as would be required for a gravity method. The authority having jurisdiction will establish the total ventilation required for a specific area. Typical ventilation requirements are shown on the chart below.

Typical Ventilation Requirements

MAXIMUM OCCUPATION CLASSIFICATION HAZARD	DISTANCE BETWEEN CENTERLINES OF ANY TWO VENTS	MAX. RATIO OF GRAVITY VENT AREA TO FLOOR AREA	MIN. CFM PER SQ. FT. OF FLOOR AREA
LOW	150 FT.	1:150	2
AVERAGE	125 FT.	1:100	3
HIGH	100 FT.	1:500	6
VERY HIGH	75 FT.	1:300	10

Mechanical exhaust ventilation, when combined with emergency gravity ventilation, can serve a dual purpose of providing the necessary process ventilation while also contributing to insurance companies' recommended requirements for providing emergency ventilation, even in the event of power failure.

Power for roof ventilators installed under IRI recommendations should be independent of the general building power supply. Wiring should be on the roof of the building or outside of the hazardous area. The electrical control system should provide for continuous power supply to the ventilators, even in the event the main power to the building is cut or turned off. The ventilator controls should be located near the points of

entrance into the building area. These controls should be wired so automatic devices activated by the sprinkler system, smoke or heat sensors, or other similar devices can override them.

This information is to provide general guidelines. Details for installation of ventilators and their control systems should be determined for each individual application. Final approval of the total installation design should be obtained from the authority having jurisdiction.

Selection

- When capacity is expressed in total CFM, select ventilators from the performance data on page 4 or 5.
- When capacity is expressed in CFM per square foot of floor area, calculate the required CFM:

$$\text{CFM} = \text{Sq. Ft. of Floor Area} \times \text{CFM/Sq. Ft.}$$

- When capacity is expressed in square feet of gravity ventilator area, the CFM can be calculated by multiplying the gravity ventilator area by 300:

$$\text{CFM} = 300 \times \text{Required Sq. Ft. of Gravity Ventilator Area}$$

All models of the SV40 Roof Ventilators shown in this catalog have sufficient velocity to fully open steel dampers in the ventilator stack cap. The table below lists the minimum CFM requirement for each fan size for fully open damper operation. Minimum CFM required to open aluminum dampers are also shown in the table below.

DAMPER MATERIAL	CFM PER DAMPER SIZE							
	24"	30"	36"	42"	48"	54"	60"	
STEEL	MIN.	5450	8480	12350	16950	22025	27780	34205
	MAX.	9615	14965	21785	29885	38865	49020	60355
ALUM.	MIN.	4170	6485	9445	12955	16845	21245	26155
	MAX.	9615	14965	21785	29885	38865	49020	60355

Performance Data – Belt Driven

SV40 – Smoke and Heat Removal Roof Ventilator

PROP	FAN TYPE	RPM	MOTOR HP	MAX. BHP	LwIA	STATIC PRESSURE (IN. W.G.)														
						0.000	0.125	0.250	0.375	0.500	0.625	0.750	0.875	1.000	1.250	1.500				
						CFM	CFM	CFM	CFM	CFM	CFM	CFM	CFM	CFM	CFM	CFM				
24Z545	SV40	745	1/3	0.33	75	4638														
24Z535	SV40	867	1/3	0.33	77	4755	4044	3202												
24Z545	SV40	854	1/2	0.50	79	5316	4599													
24Z535	SV40	995	1/2	0.50	80	5457	4799	4256												
24Z545	SV40	978	3/4	0.75	83	6088	5492													
24Z535	SV40	1136	3/4	0.75	83	6230	5627	5175	4601											
24Z545	SV40	1076	1	1.00	85	6698	6174													
24Z535	SV40	1251	1	1.00	86	6860	6301	5867	5437	4787										
24Z545	SV40	1356	2	2.00	91	8441	8046	7574	7008											
24Z535	SV40	1576	2	2.00	92	8643	8179	7779	7445	7130	6749	6257								
24Z545	SV40	1552	3	3.00	95	9661	9322	8939	8497	7972										
24Z535	SV40	1803	3	2.99	96	9888	9474	9108	8780	8498	8224	7918	7544	7081						
30Z545	SV40	659	1/2	0.49	77	7509														
30Z535	SV40	782	1/2	0.50	79	7524	6529	5307												
30Z545	SV40	754	3/4	0.74	80	8592	7230													
30Z535	SV40	895	3/4	0.75	82	8612	7760	6779												
30Z545	SV40	830	1	0.99	83	9458	8255													
30Z535	SV40	985	1	1.00	85	9478	8713	7857	6893											
30Z545	SV40	951	1½	1.50	88	10837	9818	8389												
30Z535	SV40	1128	1½	1.50	89	10854	10194	9478	8690	7829										
30Z545	SV40	1047	2	2.00	89	11931	11023	9952												
30Z535	SV40	1241	2	1.99	92	11941	11345	10710	10024	9285	8461									
30Z545	SV40	1198	3	3.00	93	13651	12874	11991	10899											
30Z535	SV40	1421	3	3.00	95	13673	13157	12615	12043	11437	10790	10124	9233							
30Z545	SV40	1420	5	5.00	97	16181	15537	14832	14065	13179										
30Z535	SV40	1685	5	4.99	100	16213	15781	15333	14870	14388	13886	13361	12812	12259	10788					
36Z545	SV40	556	3/4	0.74	78	10948														
36Z535	SV40	660	3/4	0.75	80	10974	9561	7857												
36Z545	SV40	613	1	0.99	81	12071	10036													
36Z535	SV40	727	1	1.00	82	12088	10825	9363												
36Z545	SV40	702	1½	1.49	83	13823	12121													
36Z535	SV40	832	1½	1.50	86	13834	12748	11538	10187											
36Z545	SV40	772	2	2.00	86	15201	13686													
36Z535	SV40	916	2	1.99	89	15230	14253	13188	12009	10656										
36Z545	SV40	884	3	3.00	90	17407	16120	14612												
36Z535	SV40	1049	3	3.00	93	17442	16596	15696	14729	13684	12558									
36Z545	SV40	1048	5	5.00	95	20636	19576	18382	17037											
36Z535	SV40	1243	5	4.99	98	20667	19960	19222	18448	17632	16768	15871	14902	13446						
36Z545	SV40	1198	7½	7.47	98	23590	22674	21675	20589	19362										
36Z535	SV40	1423	7½	7.48	101	23660	23046	22411	21754	21072	20362	19621	18844	18062	16123					
42Z545	SV40	445	1	1.00	78	15256	12431													
42Z530	SV40	584	1	0.99	84	14474	12788	11030												
42Z545	SV40	510	1½	1.50	82	17484	15055													
42Z530	SV40	669	1½	1.50	88	16581	15111	13632	11985											
42Z545	SV40	561	2	1.98	84	19233	17000													
42Z530	SV40	736	2	2.00	91	18242	16907	15568	14163	12501										
42Z545	SV40	642	3	3.00	88	22010	20059	18129												
42Z530	SV40	843	3	2.99	96	20894	19730	18557	17389	16139	14038	12686								
42Z545	SV40	761	5	4.98	92	26089	24454	22812	21086											
42Z530	SV40	999	5	5.00	101	24760	23779	22792	21803	20820	19361	18704	17496	15916						
42Z545	SV40	871	7½	7.45	95	29860	28437	26979	25599	23980										
42Z530	SV40	1144	7½	7.47	103	28354	27498	26638	25774	24911	23707	23175	22247	21290	18972					
42Z545	SV40	959	10	9.98	98	32877	31588	30272	28964	27726										
42Z530	SV40	1259	10	9.96	106	31204	30427	29646	28863	28076	26984	26516	25722	24891	23148	21021				

NOTES:

1. Performance shown is for installation Type A: Free inlet, free outlet.
2. Power rating (BHP) does not include drive losses.
3. Performance ratings do not include the effects of appurtenances in the airstream.
4. The sound power ratings shown are in decibels, referred to 10⁻¹² watts calculated per AMCA Standard 301.
5. Values shown are for inlet LwIA sound power levels for installation Type A: Free inlet, free outlet. Ratings do not include the effects of end correction.
6. Sound power values shown are at the peak cataloged pressure for each RPM.

Performance Data – Belt Driven

SV40 – Smoke and Heat Removal Roof Ventilator

PROP	FAN TYPE	RPM	MOTOR HP	MAX. BHP	LwiA	STATIC PRESSURE (IN. W.G.)															
						0.000	0.125	0.250	0.375	0.500	0.625	0.750	0.875	1.000	1.250	1.500					
						CFM	CFM	CFM	CFM	CFM	CFM	CFM	CFM	CFM	CFM	CFM					
48Z545	SV40	434	1½	1.48	81	20257	16228														
48Z535	SV40	515	1½	1.50	82	20297	17900	15084													
48Z545	SV40	478	2	1.98	83	22310	18892														
48Z535	SV40	567	2	1.98	84	22347	20200	17735													
48Z545	SV40	547	3	2.99	86	25531	22642														
48Z535	SV40	649	3	2.99	88	25578	23731	21691	19430												
48Z545	SV40	648	5	4.98	91	30245	27894	25102													
48Z535	SV40	770	5	4.99	93	30347	28810	27168	25396	23485	21305										
48Z545	SV40	742	7½	7.48	95	34632	32621	30336	27416												
48Z535	SV40	881	7½	7.49	97	34722	33389	31988	30510	28939	27267	25531	23099								
48Z545	SV40	817	10	9.97	97	38133	36326	34311	32101												
48Z535	SV40	970	10	9.94	99	38230	37024	35769	34459	33086	31639	30115	28565	26689							
54Z545	SV40	329	1½	1.48	77	23718															
54Z530	SV40	430	1½	1.50	84	22765	19928	16843													
54Z545	SV40	362	2	1.99	81	26097	21886														
54Z530	SV40	473	2	1.97	87	25041	22473	19758	16182												
54Z545	SV40	415	3	3.00	84	29917	26306														
54Z530	SV40	541	3	2.98	90	28641	26408	24105	21630	18122											
54Z545	SV40	492	5	5.00	89	35468	32494	29137													
54Z530	SV40	642	5	4.99	95	33988	32117	30197	28239	26151	23779										
54Z545	SV40	563	7½	7.49	92	40587	38036	35251													
54Z530	SV40	735	7½	7.49	98	38912	37282	35620	33931	32210	30388	28473	25966								
54Z545	SV40	619	10	9.96	95	44624	42326	39801	37198												
54Z530	SV40	809	10	9.99	101	42829	41351	39849	38321	36783	35205	33544	31832	29823							
54Z545	SV40	709	15	14.97	98	51112	49128	46997	44765	42433											
54Z530	SV40	926	15	15.00	105	49023	47735	46430	45108	43770	42428	41065	39655	38192	35058	30085					
60Z545	SV40	320	2	1.97	79	30484	24072														
60Z530	SV40	422	2	1.99	85	29073	25781	21948													
60Z545	SV40	366	3	2.98	83	34866	29696														
60Z530	SV40	483	3	3.00	89	33276	30440	27322	23603												
60Z545	SV40	434	5	4.97	87	41344	37025														
60Z530	SV40	573	5	5.00	95	39476	37118	34602	31886	28775	24916										
60Z545	SV40	497	7½	7.47	91	47345	43638	39676													
60Z530	SV40	655	7½	7.46	97	45126	43077	40927	38668	36246	33553	30430									
60Z545	SV40	547	10	9.96	94	52108	48772	45215	40481												
60Z530	SV40	721	10	9.96	101	49673	47820	45892	43882	41787	39540	37085	34314	31043							
60Z545	SV40	627	15	14.99	97	59729	56848	53767	50662	45853											
60Z530	SV40	827	15	15.00	104	56975	55367	53711	52002	50238	48420	46515	44478	42298	37211						
60Z545	SV40	690	20	19.98	100	65731	63127	60379	57542	54620											
60Z530	SV40	909	20	19.94	106	62625	61165	59670	58137	56561	54947	53290	51568	49752	45790	41113					
60Z545	SV40	743	25	24.95	102	70780	68371	65848	63203	60607	57622										
60Z530	SV40	979	25	24.94	107	67447	66095	64713	63302	61859	60381	58874	57330	55735	52314	48514					

NOTES:

1. Performance shown is for installation Type A: Free inlet, free outlet.
2. Power rating (BHP) does not include drive losses.
3. Performance ratings do not include the effects of appurtenances in the airstream.
4. The sound power ratings shown are in decibels, referred to 10⁻¹² watts calculated per AMCA Standard 301.
5. Values shown are for inlet LwiA sound power levels for installation Type A: Free inlet, free outlet. Ratings do not include the effects of end correction.
6. Sound power values shown are at the peak cataloged pressure for each RPM.

Dimensional Data

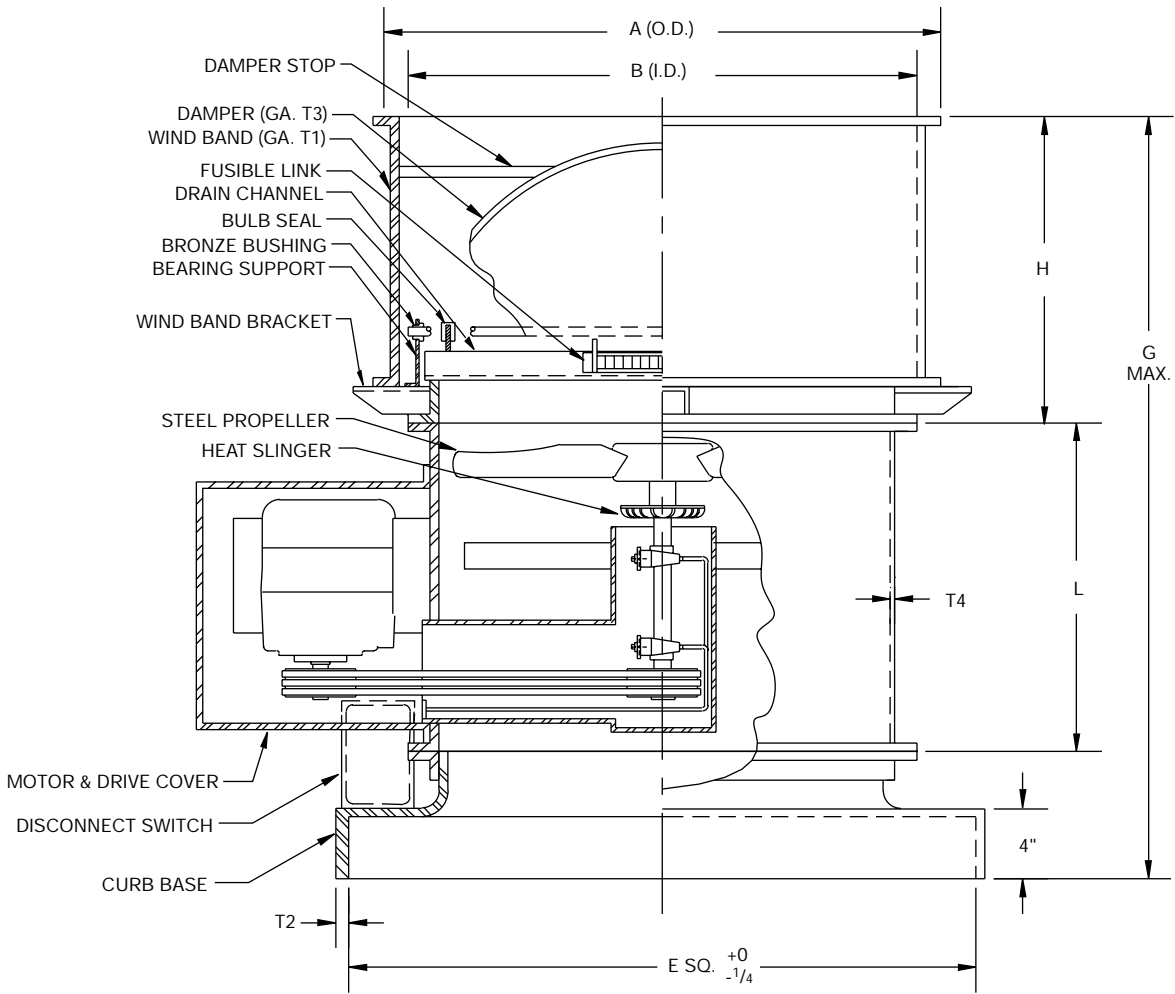

SIZE	A	B	E	G	H	L	GAUGE STEEL				MTR. FRAME SIZE	
							T1	T2	T3	T4	MIN.	MAX.
24	31 ³ / ₄	28 ⁷ / ₈	35 ⁷ / ₈	60 ¹ / ₄	24 ³ / ₄	24	14	14	24	12	48	184T/U
30	39 ³ / ₄	36 ⁷ / ₈	43 ⁷ / ₈	66 ³ / ₄	27 ³ / ₄	27	14	14	20	12	48	215T/U
36	45 ³ / ₄	42 ⁷ / ₈	49 ⁷ / ₈	76 ³ / ₄	30 ³ / ₄	34	14	14	20	10	56	256T/U
42	51 ³ / ₄	48 ⁷ / ₈	55 ⁷ / ₈	79 ³ / ₄	33 ³ / ₄	34	14	14	20	10	143T/U	256T/U
48	57 ³ / ₄	54 ⁷ / ₈	61 ⁷ / ₈	84 ³ / ₄	36 ³ / ₄	36	14	14	20	7	143T/U	256T/U
54	64	60 ³ / ₄	67 ³ / ₄	99 ³ / ₄	39 ³ / ₄	48	14	12	20	7	143T/U	256T/U
60	70	66 ³ / ₄	74 ³ / ₄	103 ³ / ₄	43 ³ / ₄	48	14	12	20	7	143T/U	286T/U

DIMENSIONS ARE NOT TO BE USED FOR CONSTRUCTION.

Typical Specifications

SV40 Smoke and Heat Roof Ventilators, where indicated on drawings and schedules, shall be of the belt driven tubeaxial type, Arrangement 9, as manufactured by Aerovent, Minneapolis, Minnesota and shall be of the size and capacity as indicated in the fan schedule. Fans shall have the propellers mounted on separate shaft and bearing assemblies in an enclosed tube with V-belt drives with a minimum 1.3 service factor. Units shall be complete with a factory mounted NEMA 3R nonfused disconnect switch, motor cover, stack cap damper assembly with fusible link for vertical upblast discharge and a curb base to facilitate mounting the roof ventilator assembly to a roof curb. SV40 Smoke and Heat Roof Ventilators shall be designed to withstand continuous operation with internal airstream temperatures of 600°F and a minimum of 8 hours with internal airstream temperatures of 1000°F. SV40 Smoke and Heat Roof Ventilators shall be tested and certified in accordance with industry accepted test codes and guaranteed by the manufacturer to deliver at the rated published performance levels. In addition, each unit shall be factory run tested prior to shipment.

CONSTRUCTION — Fan casings shall be welded 12-gauge hot rolled steel in sizes 24" and 30" diameter, 10-gauge hot rolled steel in sizes 36" and 42" diameter and 7-gauge hot rolled steel in sizes 48" diameter and larger. Inlet and outlet flanges shall be integrally rolled mechanically from fan casing sheet steel to insure concentricity and alignment of flanges. Fan casing flanges shall be match drilled to facilitate bolted connection to the stack cap and curb base. Concentricity of fan casing shall be insured through the use of welding jigs and fixtures. A fabricated adjustable steel, multi-frame jack-screw type motor support of minimum 3/16" steel plate supported by threaded rod shall be welded to the exterior of the fan casing.

PROPELLERS — The propeller blades and hub shall be of heavy-gauge steel and shall be statically balanced and then attached to a step shaft with a retaining bolt and washer.

BEARINGS — All fans are to be supplied with sealed pillow block bearings with grease lines brought to the outside of the fan casing to facilitate servicing. Bearings shall have a minimum L-10 life as defined by AFBMA of at least 20,000 hours (100,000 hours average life). All bearings shall be lubricated with high temperature grease.

MOTORS — Fan motors shall be foot mounted NEMA Design B, standard industrial, continuous duty, ball bearing (ODP or TEFC), variable torque type, suitable for operation on voltage, phase and hertz, as listed in the fan schedule. An OSHA type louver ventilated motor cover shall be bolted to the exterior of the fan to provide personnel and drip-proof protection of the motor and drive tube.

HIGH TEMPERATURE CONSTRUCTION — High temperature construction features shall include a heat slinger cast of A240 high temperature aluminum alloy. This radial bladed heat sink fan wheel shall draw cooling air from the exterior of the fan housing through the drive tube and over the bearings, absorbing and dissipating shaft heat. A heat shield shall be provided to protect the motor from radiated heat.

Sheaves shall be cast iron with two heat-resistant static conducting belts. Bearings and belts are enclosed in an air insulated housing for protection.

CURB BASE — Base shall be fabricated from a minimum of 14-gauge steel in sizes 24" through 48" diameter, 12-gauge steel in sizes 54" and 60" diameter. The curb base shall have a smoothly radiused integral inlet bell to minimize inlet losses to the fan.

STACK CAP DAMPERS ASSEMBLY— Dampers shall be heavy duty butterfly type. The windband shall be rolled of 14-gauge steel. Damper blades shall be fabricated from 24-gauge steel in 24" fan diameter and 20-gauge steel from 30" through 60" fan diameter. All edges of the damper blades are to have a formed pie crust edge to provide maximum strength and rigidity. Heavy duty steel damper rods shall rotate on rustproof oil impregnated bronze bushings.

For emergency situations if the fan fails to energize, a thermally activated fusible link kit shall be supplied. This will automatically open the stack cap damper and provide venting in case of fire. The fusible link shall retain a spring loaded actuator until the temperature reaches 160°F or 212°F, at which time the dampers open.

BALANCING — The propeller assembly shall be statically and dynamically balanced in accordance with ANSI/AMCA 204-96 "Balance Quality and Vibration Levels for Fans" to Fan Application Category BV-3, Balance Quality Grade G6.3. In addition, belt driven fan propellers shall be balanced on the fan shaft after final assembly in the fan casing, in the manufacturing facility, to the following peak velocity values, filter-in, at the fan test speed:

Fan Application Category	Rigidly Mounted (in./s)	Flexibly Mounted (in./s)
BV-3	0.15	0.20

FINISH — The units, after fabrication, shall be cleaned and chemically pretreated by a phosphatizing process and shall be painted inside and outside with an alkyd primer and finish painted with an air dry enamel.

OPTIONAL ACCESSORIES — The fan(s) shall be furnished complete with

- Bird Screen / Outlet Safety Screen
- Inlet Safety Screen