



BULLETIN 920

December 2009

CAST IRON PRESSURE BLOWERS

Model CPB



CPB Cast Iron Pressure Blowers

Aerovent's CPB Cast Iron Pressure Blowers are the perfect choice for providing low volume, high pressure air for cooling, ventilating and exhaust systems which handle dust, materials or corrosive fumes. These direct drive or belt driven blowers feature heavy duty cast iron housings with cast aluminum wheels for extra long life and trouble-free service.

Capabilities

- 4 wheel sizes, 7", 8", 10", and 14"
- Airflow capacities to 2000 CFM
- Static pressures to 12"
- Temperatures to 250°F (Arrangement 4 to 180°F)
- Arrangement 1, 4, 9, 9F, and 10 available

Features

- Rugged cast grey iron housing is inherently corrosion and wear resistant
- Cast aluminum radial blade wheel is corrosion and spark resistant
- Rotatable to eight discharge positions
- 200,000 hour average life bearings on belt driven units
- Round inlet and discharge for easy duct connections
- Heavy housings reduce housing radiated noise levels
- Heavy housings impede impact noise from material passing through the fan.

Applications

- Laboratory fume hood exhaust
- Polishing and grinding machine dust removal
- Welding fume exhaust
- Combustion air supply
- Raw materials, waste, and fibers conveying
- Drying processes
- General exhaust applications

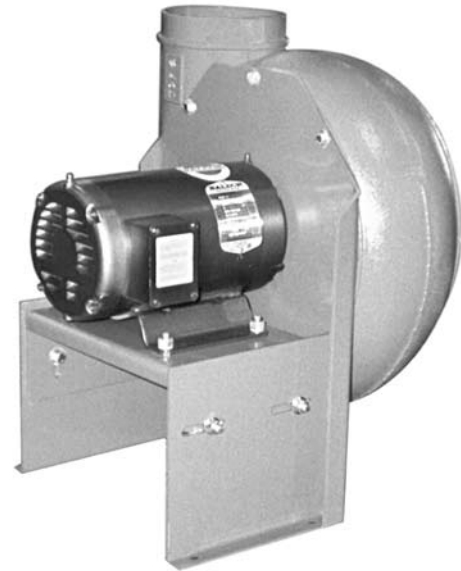
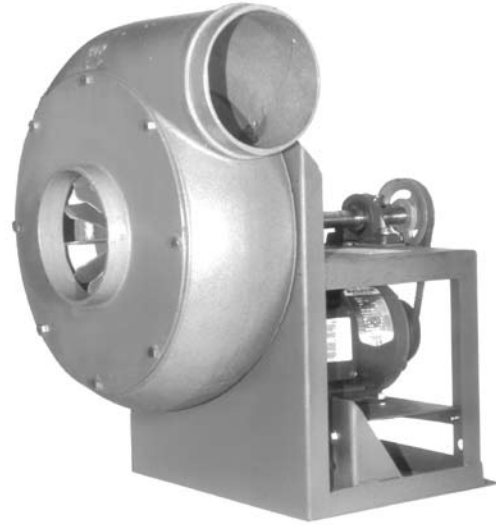

Performance Data — Direct Drive

SIZE	RPM	HP	CFM AT STATIC PRESSURE											
			0.25"	0.5"	0.75"	1"	1.5"	2"	2.5"	3"	3.5"	4"	4.5"	5"
7	1725	1/4	97	72	42	—	—	—	—	—	—	—	—	—
	3400	1/3	221	210	200	189	165	140	113	74	—	—	—	—
8	1725	1/4	198	168	131	90	—	—	—	—	—	—	—	—
	3400	1/3	—	—	—	389	358	326	290	252	213	167	109	—
	3450	1/2	443	427	412	397	366	335	300	262	225	181	127	—
10	1725	1/4	376	341	305	268	174	—	—	—	—	—	—	—
	3450	1	—	—	—	—	—	682	646	609	572	535	496	449
	3450	1½	806	788	770	752	717	682	646	609	572	535	496	449
14	1725	1	1158	1115	1071	1025	924	813	691	545	334	—	—	—
	3500	7½	—	—	—	—	—	—	2225	2181	2136	2090	2043	1994

©2009 Twin City Fan Companies, Ltd.

Bulletin illustrations cover the general appearance of Aerovent products at the time of publication and we reserve the right to make changes in design and construction at any time without notice.

Performance Data — Belt Driven

Size 7 CPB

Outlet Area: 0.04 Sq. Ft.

Wheel Dia. 6.75 In.

Tip Speed: 1.77 x RPM

CFM	OV	CFM AT STATIC PRESSURE																	
		0.25"		0.5"		0.75"		1"		1.5"		2"		2.5"		3"		3.5"	
		RPM	BHP	RPM	BHP	RPM	BHP	RPM	BHP	RPM	BHP	RPM	BHP	RPM	BHP	RPM	BHP	RPM	BHP
20	526																		
30	789	1033	0.00	1387	0.00														
40	1053	1111	0.00	1445	0.01	1716	0.01												
50	1316	1208	0.00	1515	0.01	1776	0.01	2003	0.01										
60	1579	1309	0.01	1604	0.01	1846	0.01	2066	0.02	2446	0.03	2775	0.03						
70	1842	1415	0.01	1702	0.01	1932	0.02	2137	0.02	2507	0.03	2829	0.04	3117	0.05				
80	2105	1525	0.01	1802	0.02	2029	0.02	2223	0.03	2575	0.04	2890	0.05	3173	0.06	3432	0.07	3674	0.08
90	2368	1642	0.01	1906	0.02	2127	0.03	2319	0.03	2652	0.04	2956	0.05	3234	0.07	3490	0.08	3727	0.09
100	2632	1766	0.02	2012	0.02	2228	0.03	2417	0.04	2741	0.05	3030	0.06	3301	0.08	3552	0.09	3786	0.10
110	2895	1893	0.02	2121	0.03	2332	0.04	2517	0.04	2838	0.06	3115	0.07	3374	0.09	3619	0.10	3850	0.11
120	3158	2024	0.03	2236	0.04	2437	0.04	2619	0.05	2936	0.07	3209	0.08	3456	0.10	3692	0.11	3917	0.13
130	3421	2155	0.04	2355	0.04	2545	0.05	2724	0.06	3035	0.08	3306	0.09	3547	0.11	3773	0.12	3991	0.14
140	3684	2288	0.04	2479	0.05	2657	0.06	2830	0.07	3136	0.09	3404	0.10	3644	0.12	3863	0.14		
150	3947	2423	0.05	2606	0.06	2774	0.07	2938	0.08	3239	0.10	3503	0.12	3742	0.14	3959	0.16		
160	4211	2558	0.06	2735	0.07	2894	0.08	3050	0.09	3344	0.11	3604	0.13	3840	0.15				
170	4474	2695	0.07	2866	0.08	3018	0.09	3165	0.10	3450	0.12	3707	0.15	3940	0.17				
180	4737	2832	0.09	2997	0.10	3145	0.11	3284	0.11	3558	0.14	3811	0.16						
190	5000	2971	0.10	3130	0.11	3273	0.12	3407	0.13	3668	0.15	3917	0.18						
200	5263	3110	0.11	3263	0.13	3402	0.14	3532	0.15	3781	0.17								
220	5789	3390	0.15	3533	0.16	3665	0.17	3787	0.19										

Size 8 CPB

Outlet Area: 0.06 Sq. Ft.

Wheel Dia. 8.313 In.

Tip Speed: 2.18 x RPM

CFM	OV	CFM AT STATIC PRESSURE																	
		0.25"		0.5"		0.75"		1"		1.5"		2"		2.5"		3"		3.5"	
		RPM	BHP	RPM	BHP	RPM	BHP	RPM	BHP	RPM	BHP	RPM	BHP	RPM	BHP	RPM	BHP	RPM	BHP
60	1017	922	0.00	1206	0.01	1432	0.01	1626	0.02	1955	0.03	2235	0.04	2483	0.05	2709	0.06	2917	0.07
80	1356	1018	0.01	1283	0.01	1501	0.02	1689	0.02	2011	0.03	2286	0.04	2531	0.06	2753	0.07	2958	0.08
100	1695	1117	0.01	1374	0.02	1580	0.02	1762	0.02	2075	0.04	2345	0.06	2586	0.07	2806	0.08	3008	0.10
120	2034	1229	0.01	1473	0.02	1671	0.03	1843	0.03	2148	0.05	2412	0.07	2648	0.08	2864	0.10	3065	0.12
140	2373	1349	0.02	1573	0.03	1769	0.04	1936	0.05	2228	0.06	2486	0.08	2718	0.10	2930	0.12	3127	0.14
160	2712	1474	0.03	1682	0.04	1868	0.05	2035	0.06	2317	0.08	2566	0.10	2793	0.12	3001	0.14	3195	0.16
180	3051	1603	0.04	1799	0.05	1971	0.06	2134	0.07	2413	0.09	2653	0.11	2873	0.14	3078	0.16	3269	0.18
200	3390	1736	0.05	1920	0.06	2083	0.07	2235	0.08	2512	0.11	2748	0.13	2960	0.16	3159	0.18	3346	0.21
220	3729	1870	0.06	2045	0.07	2200	0.09	2343	0.10	2611	0.13	2847	0.15	3055	0.18	3247	0.21	3429	0.24
240	4068	2006	0.08	2173	0.09	2321	0.10	2457	0.12	2712	0.15	2946	0.18	3153	0.21	3342	0.24	3518	0.27
260	4407	2144	0.10	2303	0.11	2445	0.12	2576	0.14	2817	0.17	3044	0.20	3252	0.24	3440	0.27	3613	0.30
280	4746	2283	0.12	2436	0.13	2572	0.15	2698	0.16	2929	0.20	3146	0.23	3351	0.27	3539	0.30	3711	0.34
300	5085	2423	0.14	2570	0.16	2700	0.17	2822	0.19	3045	0.22	3252	0.26	3451	0.30	3637	0.34	3810	0.38
320	5424	2565	0.17	2705	0.19	2831	0.20	2948	0.22	3165	0.26	3363	0.29	3554	0.33	3736	0.37	3909	0.42
340	5763	2707	0.20	2842	0.22	2964	0.24	3077	0.26	3286	0.30	3479	0.33	3661	0.37	3838	0.41		
360	6102	2850	0.23	2979	0.25	3097	0.28	3207	0.30	3410	0.34	3597	0.38	3773	0.42	3943	0.46		
380	6441	2993	0.27	3118	0.29	3232	0.32	3339	0.34	3535	0.38	3718	0.42	3889	0.47				
400	6780	3138	0.31	3257	0.34	3368	0.36	3472	0.39	3662	0.43	3840	0.47						
440	7458	3427	0.41	3538	0.44	3642	0.47	3740	0.49	3922	0.54								
480	8136	3719	0.53	3822	0.56	3920	0.59												

CFM	OV	CFM AT STATIC PRESSURE																	
		4"		5"		6"		7"		8"		9"		10"		11"		12"	
		RPM	BHP	RPM	BHP	RPM	BHP	RPM	BHP	RPM	BHP	RPM	BHP	RPM	BHP	RPM	BHP	RPM	BHP
60	1017	3112	0.09	3469	0.12	3793	0.15												
80	1356	3149	0.10	3502	0.13	3822	0.16												
100	1695	3198	0.11	3546	0.15	3862	0.18												
120	2034	3253	0.13	3597	0.17	3910	0.21												
140	2373	3312	0.15	3653	0.19	3964	0.23												
160	2712	3377	0.18	3713	0.22														
180	3051	3448	0.21	3780	0.25														
200	3390	3523	0.23	3851	0.29														
220	3729	3603	0.27	3925	0.32														
240	4068	3687	0.30																

Bold face numbers indicate region of highest efficiency.
Power ratings (BHP) do not include drive losses.

Performance Data — Belt Driven

Size 10 CPB

Outlet Area: 0.12 Sq. Ft.

Wheel Dia. 9.875 In.

Tip Speed: 2.59 x RPM

CFM	OV	CFM AT STATIC PRESSURE																	
		0.25"		0.5"		0.75"		1"		1.5"		2"		2.5"		3"		3.5"	
		RPM	BHP	RPM	BHP	RPM	BHP	RPM	BHP	RPM	BHP	RPM	BHP	RPM	BHP	RPM	BHP	RPM	BHP
100	847	771	0.01	995	0.01	1176	0.02	1335	0.03	1604	0.04	1832	0.06						
150	1271	913	0.02	1110	0.02	1281	0.03	1425	0.04	1678	0.06	1900	0.08	2099	0.11	2280	0.13	2446	0.15
200	1695	1076	0.03	1253	0.04	1401	0.05	1541	0.06	1784	0.09	1989	0.12	2177	0.14	2352	0.17	2516	0.20
250	2119	1252	0.05	1413	0.06	1551	0.08	1672	0.09	1900	0.12	2104	0.16	2284	0.19	2447	0.22	2601	0.25
300	2542	1436	0.07	1581	0.09	1710	0.11	1826	0.13	2030	0.16	2220	0.20	2400	0.24	2563	0.28	2712	0.32
350	2966	1625	0.11	1758	0.13	1877	0.15	1987	0.17	2182	0.21	2354	0.25	2519	0.30	2678	0.34	2828	0.39
400	3390	1818	0.16	1941	0.18	2050	0.21	2153	0.23	2340	0.28	2507	0.32	2658	0.37	2803	0.42	2945	0.47
450	3814	2013	0.22	2128	0.24	2230	0.27	2326	0.30	2503	0.35	2665	0.41	2811	0.46	2947	0.51	3077	0.56
500	4237	2211	0.29	2318	0.32	2415	0.35	2504	0.38	2671	0.44	2826	0.50	2969	0.56	3102	0.62	3225	0.67
550	4661	2411	0.38	2510	0.41	2602	0.44	2687	0.48	2844	0.55	2992	0.61	3130	0.68	3260	0.74	3381	0.81
600	5085	2612	0.48	2705	0.52	2791	0.55	2873	0.59	3022	0.67	3162	0.74	3295	0.81	3421	0.88	3540	0.96
650	5508	2814	0.61	2901	0.65	2983	0.68	3061	0.72	3204	0.80	3337	0.89	3464	0.96	3585	1.04	3701	1.12
700	5932	3017	0.75	3099	0.79	3177	0.84	3251	0.88	3388	0.96	3516	1.05	3637	1.14	3753	1.22	3865	1.31
750	6356	3220	0.92	3298	0.96	3372	1.01	3442	1.05	3575	1.14	3697	1.24	3814	1.33	3925	1.42		

CFM	OV	CFM AT STATIC PRESSURE																	
		4"		5"		6"		7"		8"		9"		10"		11"		12"	
		RPM	BHP	RPM	BHP	RPM	BHP	RPM	BHP	RPM	BHP	RPM	BHP	RPM	BHP	RPM	BHP	RPM	BHP
250	2119	2749	0.28	3024	0.35	3277	0.42	3512	0.49	3730	0.57	3936	0.64						
300	2542	2851	0.35	3111	0.43	3355	0.51	3585	0.59	3801	0.67								
350	2966	2968	0.43	3221	0.52	3453	0.61	3672	0.70	3881	0.79								
400	3390	3083	0.52	3338	0.62	3567	0.73	3779	0.83	3978	0.93								
450	3814	3205	0.61	3453	0.73	3684	0.85	3896	0.97										
500	4237	3344	0.73	3575	0.85	3799	0.98												
550	4661	3496	0.87	3713	0.99	3922	1.12												
600	5085	3653	1.03	3862	1.16														

Size 14 CPB

Outlet Area: 0.23 Sq. Ft.

Wheel Dia. 14 In.

Tip Speed: 3.67 x RPM

CFM	OV	CFM AT STATIC PRESSURE																	
		0.25"		0.5"		0.75"		1"		1.5"		2"		2.5"		3"		3.5"	
		RPM	BHP	RPM	BHP	RPM	BHP	RPM	BHP	RPM	BHP	RPM	BHP	RPM	BHP	RPM	BHP	RPM	BHP
200	877	530	0.02	689	0.03	818	0.04	931	0.06	1122	0.09	1285	0.12	1429	0.15	1561	0.18	1682	0.22
300	1316	623	0.03	764	0.05	883	0.07	985	0.09	1165	0.13	1323	0.17	1465	0.21	1593	0.25	1712	0.30
400	1754	730	0.06	856	0.08	963	0.11	1061	0.13	1230	0.18	1377	0.23	1511	0.28	1636	0.34	1752	0.39
500	2193	847	0.10	959	0.13	1058	0.16	1147	0.19	1307	0.25	1449	0.31	1576	0.37	1693	0.44	1803	0.50
600	2632	972	0.16	1071	0.19	1162	0.22	1245	0.26	1393	0.33	1528	0.41	1652	0.48	1766	0.55	1871	0.63
700	3070	1102	0.23	1190	0.27	1272	0.31	1349	0.35	1490	0.44	1616	0.52	1733	0.61	1843	0.69	1947	0.77
800	3509	1235	0.34	1314	0.38	1388	0.42	1459	0.47	1592	0.56	1712	0.66	1823	0.76	1927	0.86	2026	0.95
900	3947	1370	0.47	1441	0.51	1509	0.56	1575	0.61	1698	0.72	1813	0.82	1920	0.93	2019	1.04	2113	1.15
1000	4386	1507	0.63	1572	0.68	1634	0.73	1695	0.79	1810	0.9	1919	1.02	2021	1.14	2117	1.26	2208	1.38
1200	5263	1783	1.06	1839	1.12	1892	1.18	1945	1.25	2046	1.38	2142	1.51	2234	1.65	2323	1.79	2409	1.94
1400	6140	2063	1.65	2111	1.72	2158	1.80	2204	1.87	2293	2.02	2380	2.18	2463	2.34	2543	2.49	2622	2.66
1600	7018	2345	2.44	2387	2.52	2429	2.61	2470	2.69	2550	2.86	2627	3.04	2703	3.21	2776	3.39	2848	3.57
1800	7895	2628	3.45	2666	3.54	2703	3.63	2740	3.73	2812	3.92	2882	4.11	2951	4.31	3019	4.51	3085	4.71
2000	8772	2912	4.70	2946	4.81	2980	4.91	3013	5.02	3079	5.23	3143	5.44	3207	5.66	3269	5.88	3330	6.10

CFM	OV	CFM AT STATIC PRESSURE																	
		4"		5"		6"		7"		8"		9"		10"		11"		12"	
		RPM	BHP	RPM	BHP	RPM	BHP	RPM	BHP	RPM	BHP	RPM	BHP	RPM	BHP	RPM	BHP	RPM	BHP
500	2193	1908	0.57	2104	0.70	2284	0.84	2450	0.98	2606	1.13	2752	1.27	2891	1.42	3024	1.57	3150	1.73
600	2632	1971	0.70	2157	0.86	2331	1.02	2493	1.18	2647	1.34	2792	1.51	2929	1.68	3061	1.86	3187	2.03
700	3070	2044	0.86	2224	1.04	2390	1.22	2546	1.40	2695	1.59	2837	1.77	2972	1.96	3102	2.16	3226	2.35
800	3509	2122	1.05	2299	1.24	2461	1.44	2611	1.64	2754	1.85	2891	2.06	3022	2.27	3149	2.48	3271	2.70
900	3947	2204	1.26	2376	1.48	2536	1.69	2685	1.91	2824	2.14	2956	2.37	3083	2.61	3205	2.84	3324	3.08
1000	4386	2294	1.50	2459	1.75	2615	1.99	2761	2.22	2899	2.47	3029	2.72	3153	2.97	3272	3.23	3386	3.48
1100	4825	2390	1.77	2548	2.04	2698	2.31	2840	2.57	2976	2.84	3105	3.10	3227	3.37	3344	3.64	3457	3.92
1200	5263	2490	2.08	2643	2.37	2787	2.67	2924	2.96	3056	3.25	3182	3.53	3304	3.82	3420	4.11	3532	4.41
1300	5702	2593	2.43	2742	2.74	2881	3.06	3014	3.38	3141	3.69	3264	4.01	3383	4.32	3497	4.62		
1400	6140	2698	2.82	2844	3.16	2980	3.49	3108	3.83	3231	4.18	3350	4.52	3465	4.86	3577	5.19		
1500	6579	2807	3.26	2948	3.62	3081	3.98	3206	4.34	3326	4.70	3441	5.07	3553	5.44				
1600	7018	2918	3.75	3054	4.13	3184	4.51	3307	4.89	3424	5.28	3536	5.67						
1700	7456	3033	4.30	3163	4.69	3289	5.09	3409	5.50	3525	5.91								
1800	7895	3150	4.91	3275	5.32	3397	5.74	3514	6.16										
1900	8333	3269	5.58	3390	6.01	3507	6.44												
2000	8772	3390	6.32	3507	6.76														

Bold face numbers indicate region of highest efficiency.
Power ratings (BHP) do not include drive losses.

Dimensional Data

Arrangement 4

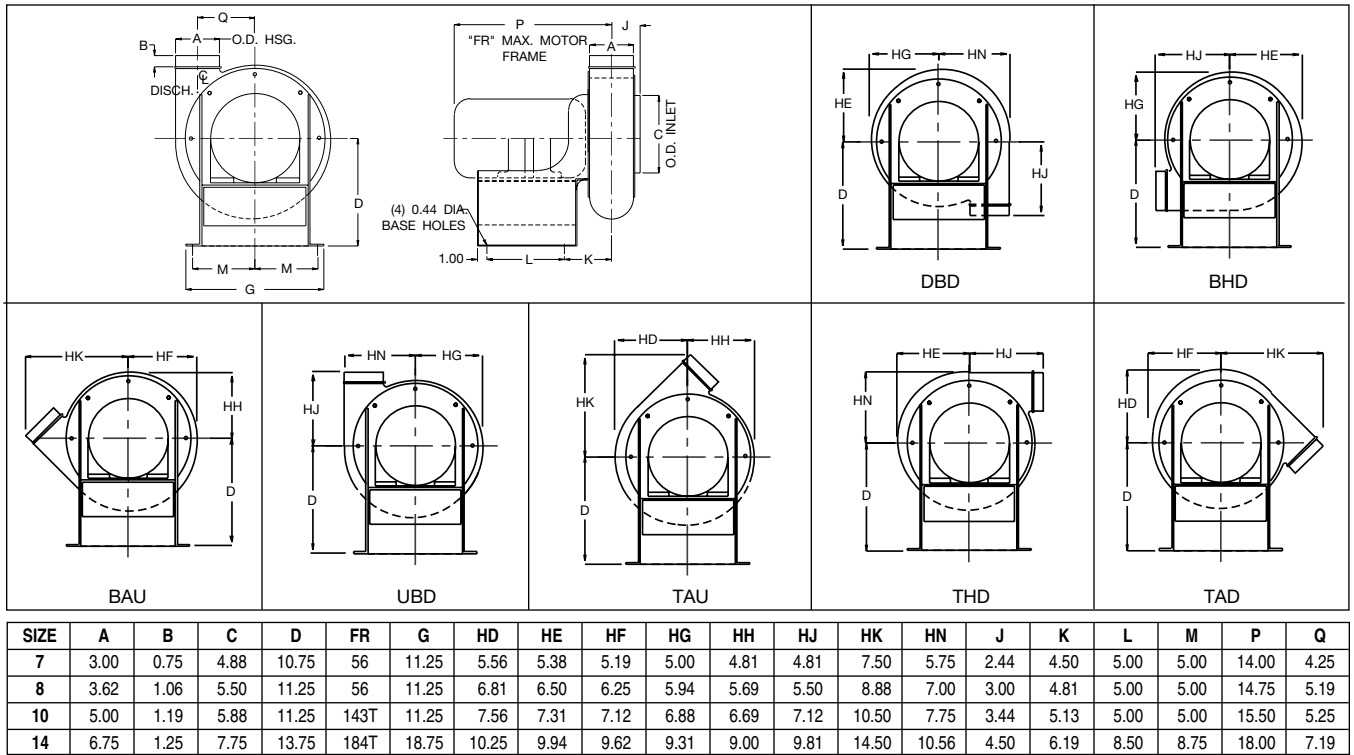

R29297C

Arrangement 10

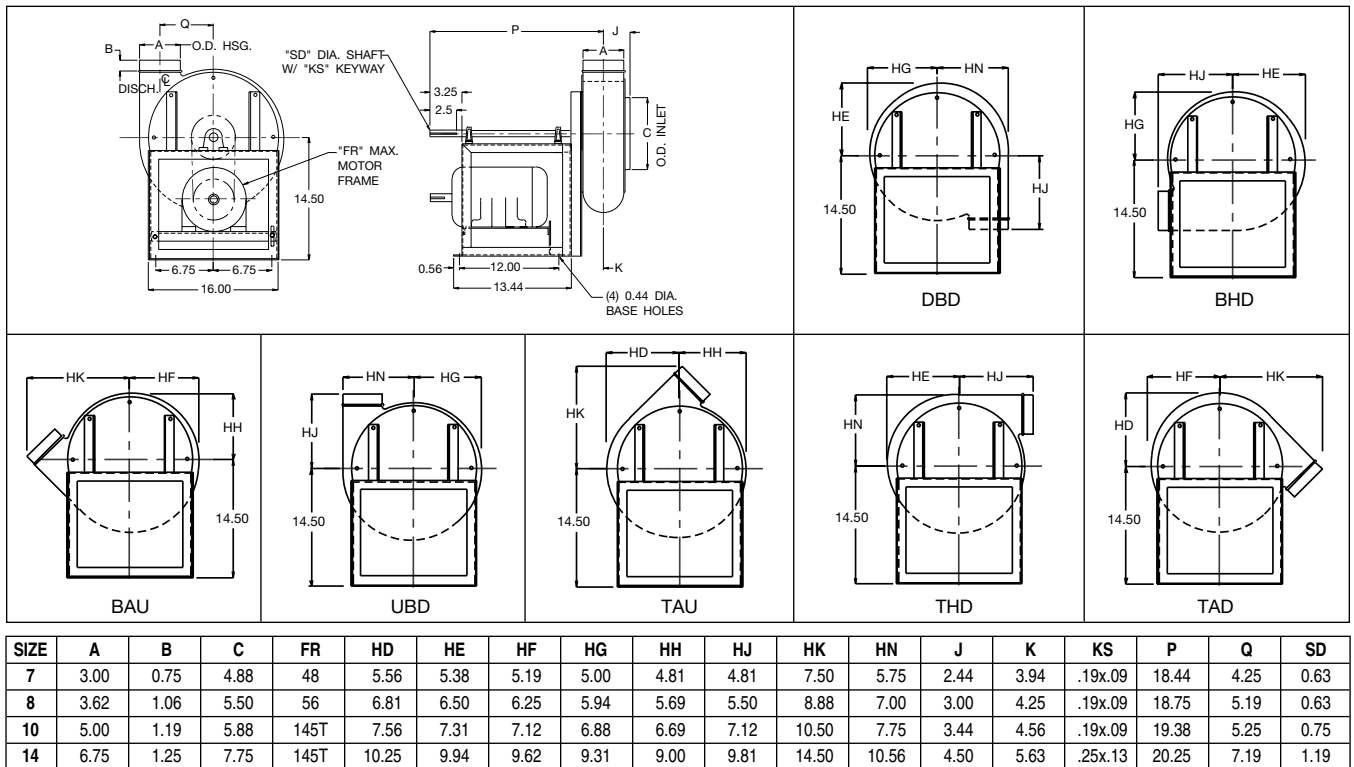

R29294C

DIMENSIONS ARE NOT TO BE USED FOR CONSTRUCTION. CERTIFIED DRAWINGS AVAILABLE UPON REQUEST.

Dimensional Data

Arrangement 1 & 9

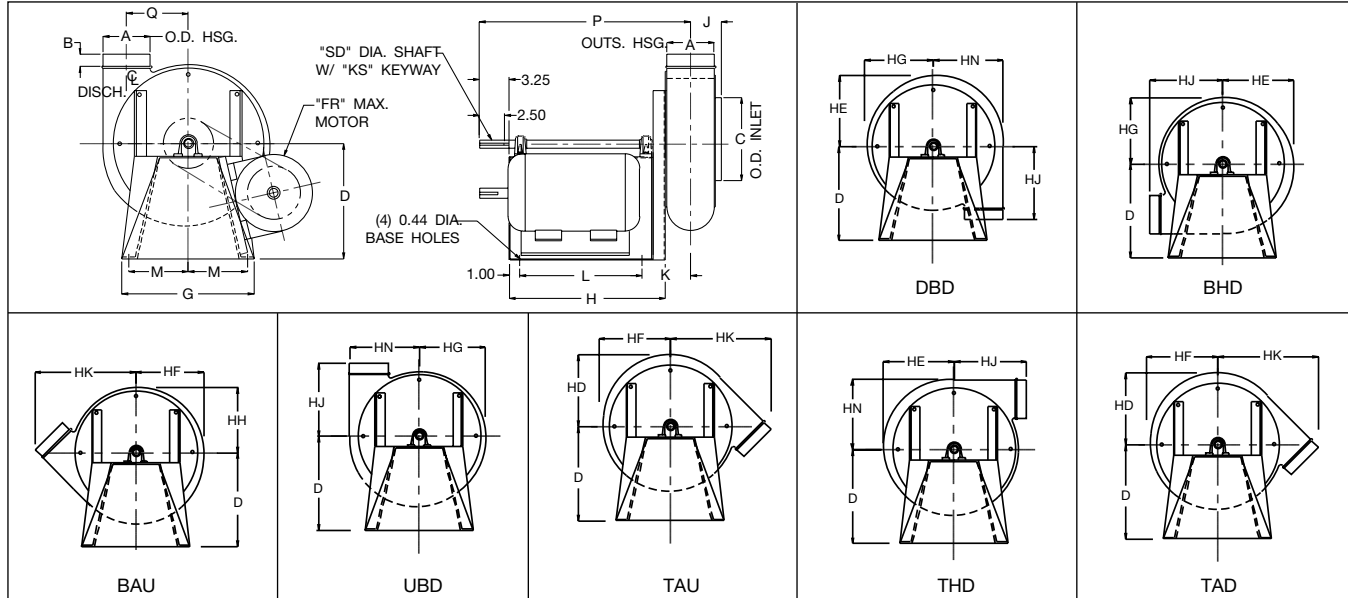

SIZE	A	B	C	D	FR	G	H	HD	HE	HF	HG	HH	HJ	HK	HN	J	K	KS	L	M	P	Q	SD
7	3.00	0.75	4.88	11.00	48	11.25	15.31	5.56	5.38	5.19	5.00	4.81	4.81	7.50	5.75	2.44	4.50	.19x.09	11.50	4.88	20.31	4.25	0.63
8	3.62	1.06	5.50	11.00	56	11.25	15.31	6.81	6.50	6.25	5.94	5.69	5.50	8.88	7.00	3.00	4.81	.19x.09	11.50	4.88	20.63	5.19	0.63
10	5.00	1.19	5.88	13.38	145T	13.25	18.63	7.56	7.31	7.12	6.88	6.69	7.12	10.50	7.75	3.44	5.25	.19x.09	14.88	5.88	24.69	5.25	0.75
14	6.75	1.25	7.75	13.50	184T	15.75	18.63	10.25	9.94	9.62	9.31	9.00	9.81	14.50	10.56	4.50	6.31	.25x.13	14.88	7.13	25.56	7.19	1.19

R29295B

Arrangement 9F

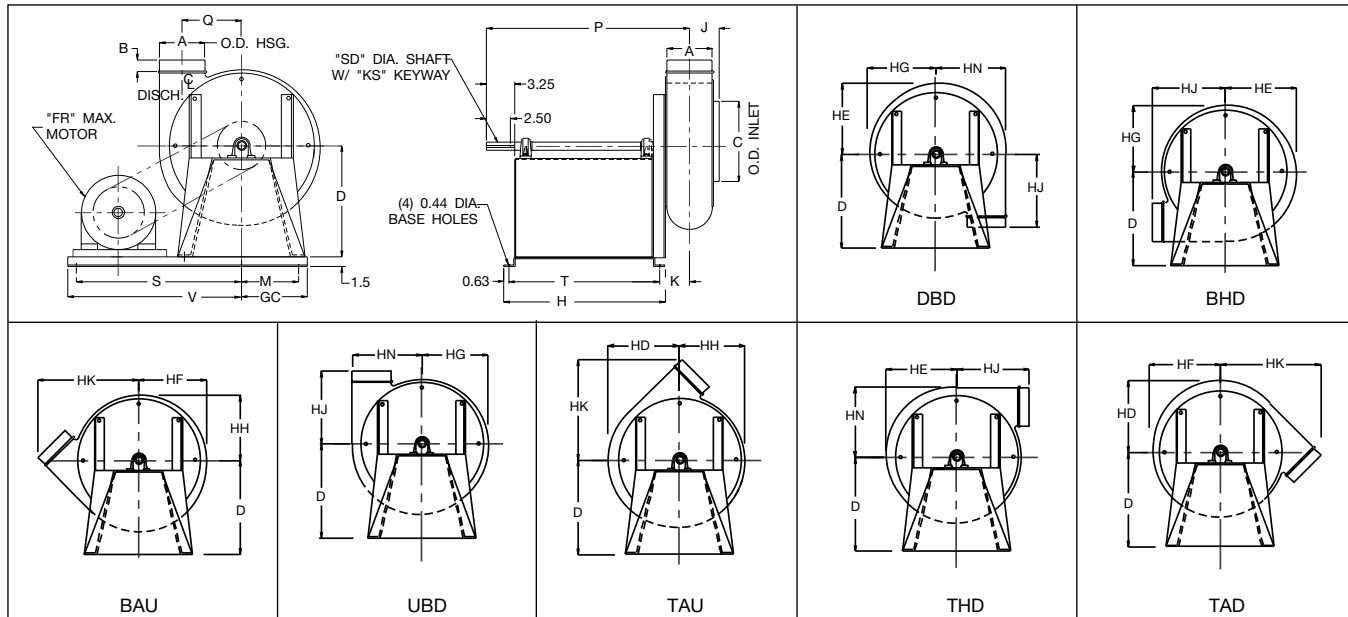

SIZE	A	B	C	D	FR	G	GC	H	HD	HE	HF	HG	HH	HJ	HK	HN	J	K	KS	M	P	Q	S	SD	T	V
7	3.00	0.75	4.88	11.00	48	11.25	5.75	17.00	5.56	5.38	5.19	5.00	4.81	4.81	7.50	5.75	2.44	2.06	.19 x .09	4.88	20.31	4.25	18.25	0.63	15.75	19.25
8	3.62	1.06	5.50	11.00	56	11.25	5.75	17.00	6.81	6.50	6.25	5.94	5.69	5.50	8.88	7.00	3.00	2.38	.19 x .09	4.88	20.63	5.19	18.25	0.63	15.75	19.25
10	5.00	1.19	5.88	13.38	145T	13.25	6.75	20.38	7.56	7.31	7.12	6.88	6.69	7.12	10.50	7.75	3.44	2.81	.19 x .09	5.88	24.69	5.25	21.38	0.75	19.13	22.38
14	6.75	1.25	7.75	13.50	184T	15.75	8.00	20.38	10.25	9.94	9.62	9.31	9.00	9.81	14.50	10.56	4.50	3.88	.25 x .13	7.13	25.56	7.19	22.63	1.19	19.13	23.63

R29296B

DIMENSIONS ARE NOT TO BE USED FOR CONSTRUCTION. CERTIFIED DRAWINGS AVAILABLE UPON REQUEST.

Typical Specifications

Furnish and install Model CPB Cast Iron Pressure Blowers, as manufactured by Aerovent, Minneapolis, Minnesota. Fans shall be of the size and arrangement as indicated in the fan schedule.

HOUSINGS — All housings shall be one-piece heavy duty cast iron construction. All units shall be built with an adjustable discharge housing which can be field rotated to any of the eight standard positions.

WHEELS — The wheel shall be of the radial bladed backplate design, and shall be cast aluminum construction. Wheels shall be suitable for exhaust purposes where low volume and high pressure applications exist.

BEARINGS — Bearings on belt driven units shall be selected to have a minimum average life of 200,000 hours (L-10 minimum life of 40,000 hours) based on AFBMA rating designations. The bearings shall be pillow block type, heavy duty, anti-friction, self-aligning ball bearings.

SHAFTS — Fan shafts shall be per AISI 1040 or 1045 hot rolled steel, accurately turned, ground, polished, and ring-gauged for accuracy. Shafts shall be sized so that the first critical speed will be at least 1.40 times the maximum operating speed.

MOTORS — Fan motors shall be foot-mounted NEMA Design B, standard industrial, continuous duty, ball bearing, variable torque type suitable for operation on voltage, phase and hertz as listed in the fan schedule. Motor bearings shall have a minimum L-10 life, as defined by AFBMA, of at least 40,000 hours (200,000 hours average life).

FINISH — The unit, after fabrication, shall be cleaned and chemically pretreated by a phosphatizing process and shall be painted inside and outside with an alkyd primer and finish painted with an air dry enamel.

BALANCING — Prior to shipment all fans shall be completely assembled and test run as a unit at the operating speed. Final balance of the completed fan assembly shall be taken by electronic equipment. Records of the vibration readings in the axial, vertical, and horizontal planes shall be maintained and a written copy of this record shall be available upon request.

SUBMITTALS — Submittals for approval of equipment shall include copies of outline drawings and pressure-volume performance curves showing point of operation.

ACCESSORIES — The fans shall be supplied with the following optional accessories:

- Inlet Screen
- Companion Flange, Inlet
- Companion Flange, Outlet
- Weather Cover (Arr. 10)
- Drain
- Drain With Plug
- Flanged Inlet – Punched
- Flanged Outlet – Punched
- Type C Spark Resistant Construction
- Motor Cover (Arr. 4)
- OSHA Belt Guard (Arr. 1, 9, or 9F)
- OSHA Shaft and Bearing Guard (Arr. 1, 9, 9F, or 10)
- Shaft Seal (Belt Driven Only)
- Type B Spark Resistant Construction
- Special Coatings
- Floor Mount Isolators, RIS (Arr. 9F)
- Floor Mount Isolators, Spring (Arr. 9F)

Fan Weights Without Motor

ARRANGEMENT	CPB-7	CPB-8	CPB-10	CPB-14
1, 4, 9, 10	29	51	74	131
9F	54	79	106	168

Motor Weights

FRAME	48	56	143T	145T	182T	184T
OPEN DP	30	33	35	44	66	68
TE	30	33	35	44	67	75

Quality Air Handling Equipment

AXIAL FLOW



Tubeaxial



Panel Fan



Mancooler



Ring Fan



Tubeaxial Adjustable Pitch

VANEAXIAL



Type VT



Type W Adjustable Pitch



Type VTF Fiberglass



Type B Higher Pressure



Axico Anti-Stall

CENTRIFUGAL

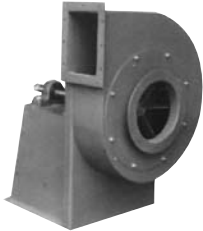

Industrial Exhaust



CB / CBA



Series 14 High Pressure



Centaxial



Pressure Blower

ROOF VENTILATOR



Upblast Propeller



Upblast Axial



Tu-WAY™



Fiberglass



PRV Centrifugal

AIR HEATER

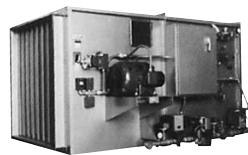

Gas-Fired Air Make-Up

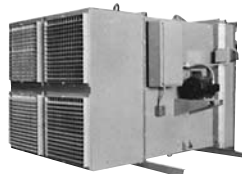

Steam Air Make-Up

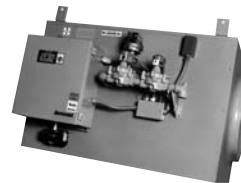

Door Air Heater

WARRANTY

Aerovent equipment is guaranteed to deliver its rated output, if properly installed and operated under normal conditions. Aerovent will correct by repair, replacement, or issuance of credit at our option, F.O.B. our plant, defects in material or workmanship which may develop under normal and proper use within eighteen (18) months after date of shipment from

our factory, if purchaser gives us notice within ten (10) days of discovering such defects. The correction of these defects by repair, replacement, or issuance of credit shall constitute fulfillment of all obligation to purchaser. (NOTE: We will not assume expense or liability for repairs made outside our factory without prior written consent.)



Aerovent

A Twin City Fan Company

5959 Trenton Lane · Minneapolis, MN 55442-3237
Phone (763) 551-7500 · Fax (763) 551-7501 · www.aerovent.com

1.5MPP12/09

