

Tubeaxial Fans

Direct-drive and belt-driven tubeaxial fans, or duct fans, as they are also called, are built to be installed in the system so as to become a part of the duct. The fan may be located at the entrance, in the middle of, or at the discharge end of the duct.

The belt-driven fan design places the motor outside of the airstream. The belt drive and bearings are enclosed in a tube and cover situated on the suction side of the impeller. For normal air handling and for high temperature operation, the bearing cover is open at the impeller end. This design induces airflow through the belt tube and bearing enclosure, creating an air insulation barrier which constantly purges contaminants and, in the case of high temperature applications, provides drive and bearing cooling. In situations where the air is wet and very contaminated with corrosive chemicals, the fan may be built with the bearing housing completely enclosed and with a seal around the impeller shaft.

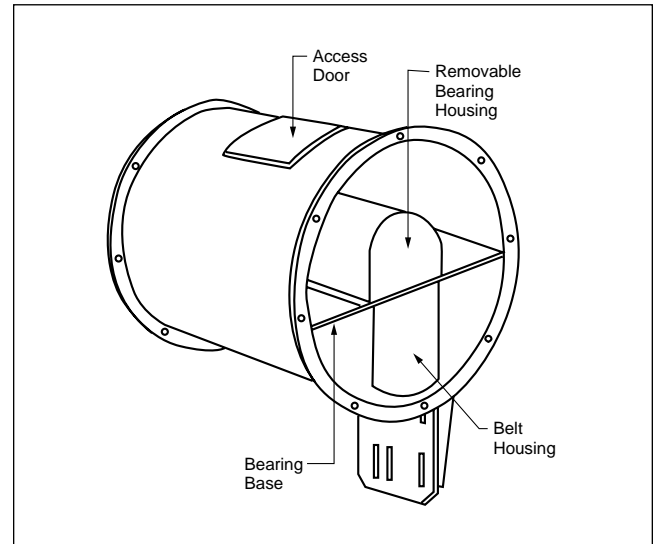

Installations

Same Size Duct

Normal fan installation. Rating tables are based on this arrangement. Variations in installations as indicated below will provide more economical fan performance but may require higher installation cost.

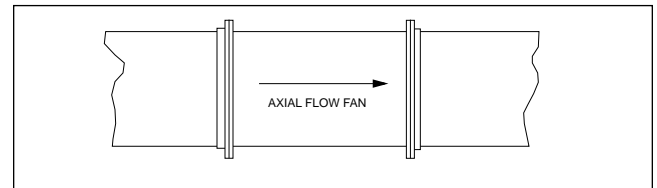

Tapered Discharge

Allows regain of a portion of the velocity pressure to static pressure. The fan can then be selected at a lower pressure for more economical operation. For specific design information, consult your Aerovent representative.

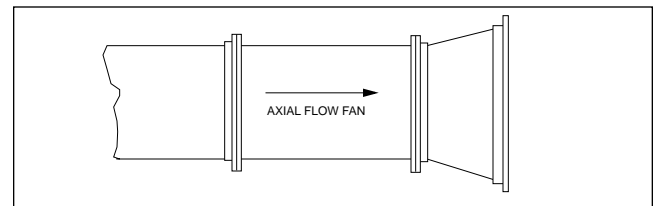

Converging Inlet & Discharge

Provides lower duct velocities and less friction to airflow. This allows choosing a fan at lower pressure for more economical operation.

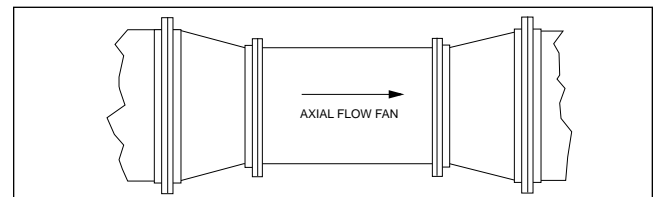

Suggested Connections For Fans In Duct Systems

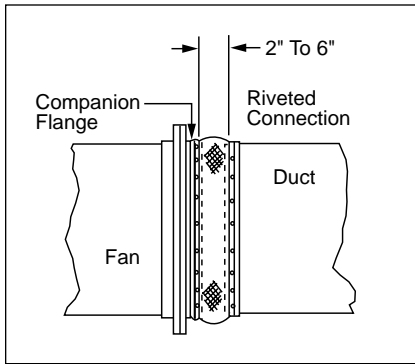

Flexible Connection
Minimum Vibration
(Use Canvas or Other
Suitable Material)

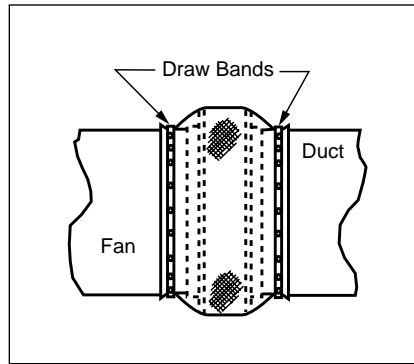

Flexible Connection
Minimum Vibration
(Use Canvas or Other
Suitable Material)

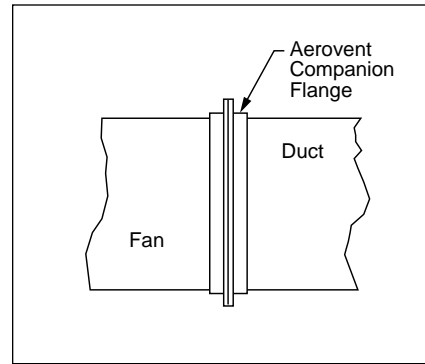

Rigid Connection

Flexible connections between the fan and duct section will reduce vibration to the duct and decrease noise. Mounting the fan on vibration isolators is also necessary for noise dampening.

Cleaning Impellers

The impeller in an axial flow fan must be kept reasonably clean if it is to perform properly. Fans handling fresh air for ventilating purposes will seldom need cleaning. Fans exhausting process air should be cleaned as required. Dirt or chemical deposits will usually build up on a impeller evenly, and they present no problem to performance or operation until they become thick

enough to break away in crust-like pieces. When this happens, the impeller may be thrown out of balance and the resulting vibration could be serious. Accumulations of deposits should be removed by solvent cleaning or scraping. If the impeller has been coated, be careful not to cut through this protective covering.

General Maintenance

Regular and systematic inspection of all fan parts is a necessity for good fan maintenance. A general installation and maintenance brochure (IM-100) has been sup-

plied with this shipment. It includes fan and motor bearing lubrication, care and replacement of V-belt drives and taperlock bushing instructions.



Aerovent

A Twin City Fan Company

5959 Trenton Lane · Minneapolis, MN 55442-3238

Phone (612) 551-7500 · Fax (612) 551-7501 · Website www.aerovent.com



MEMBER