



IM-155

June 1997

General Installation, Operation and Maintenance Instructions For Aerovent Products

Two-Way and Three-Way Heat Saver/Ventilator

Heat saver ventilators are designed to recirculate warm air from the ceiling to the work area or to exhaust air to the outside. Three-way heat savers (RREH) can also draw fresh air in from the outside and blow it down into the work area. Modulating dampers in the unit temper the air to the desired temperature setting.

Heat saver ventilators are designed to be installed through a prefab or an existing roof curb and rest on the unit's curb base section. Mount the curb base section onto the roof curb and secure the stack cap (RRES) or hooded inlet (RREH) to the fan section. Extensions of the fan section are available to provide clearance of roof and structural members.

Note: The fan must be allowed to stop before the motor rotation is reversed. Do not switch any unit from exhaust to recirculate or supply without allowing the fan blades to stop rotating.



Suggested Mounting of Three-Way Heat Saver

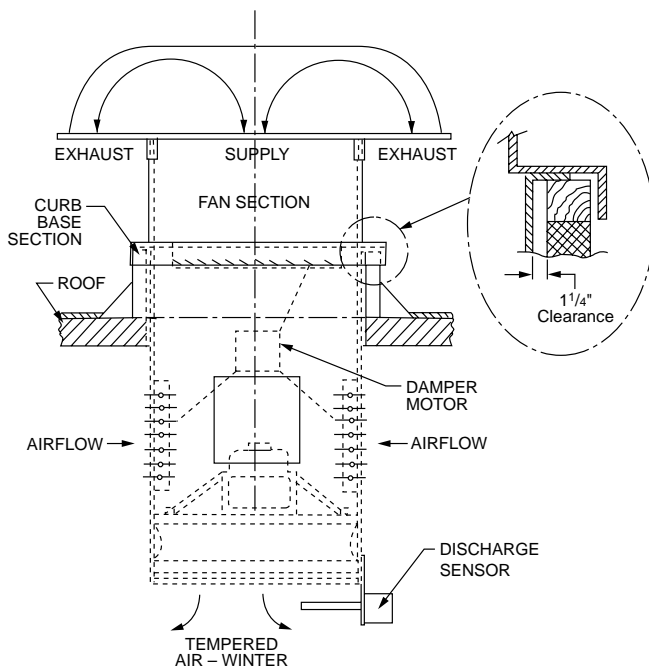

Discharge Sensor Mounting

The discharge sensor is mounted on the bottom edge of the unit so as to protrude into the tempered airstream. The temperature reading is taken at the bottom of the unit, not at the floor level. The temperature selector is located in the remote control station.

Three-Way Motor Actuated Dampers

Three-Way Heat Savers utilize three dampers, two normally open dampers mounted vertically on opposite sides for recirculation and one normally closed damper mounted horizontally in the top of the unit just below the fresh air intake/exhaust head. The three dampers are connected to one modulating motor. For recirculation, they are positioned by the discharge temperature control to recirculate all or part of the air and introduce outside air to satisfy the desired temperature. For

exhaust, the damper motor is driven fully open, closing the side dampers and opening the top damper. The damper actuating rods are left unconnected on the side recirculating dampers to facilitate shipping and easy installation. They must be reconnected to the dampers prior to start-up. No adjustment is necessary. The damper in the head is normally closed and the recirculating dampers are normally open when the actuating rods are connected.

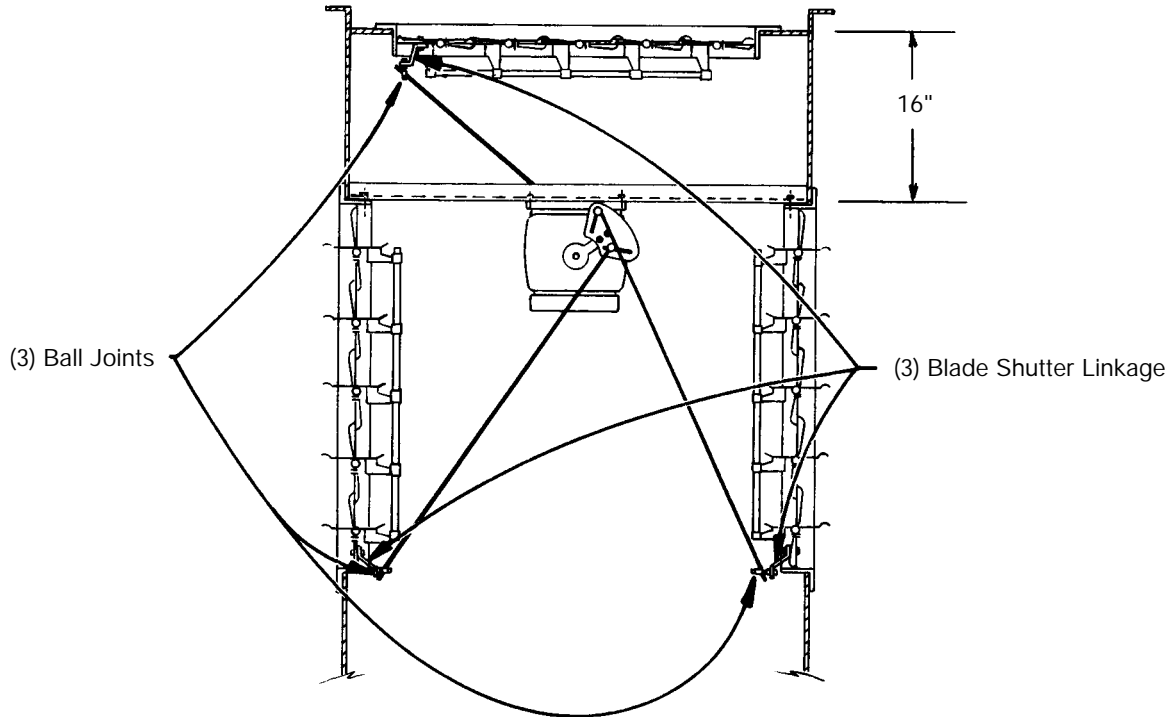

Remote Control Station Installation

The remote control station should be mounted approximately 5 feet above the floor on a stationary vertical surface. The dampers should be checked for proper operation after all of the electrical connections have been made. The recirculation dampers will be closed and the damper in the head will be in the full open position in the exhaust mode. In the supply mode, the dampers will modulate by adjusting the temperature selector. The dampers should operate freely without binding.

The control station will have a temperature selector and an on/off switch.

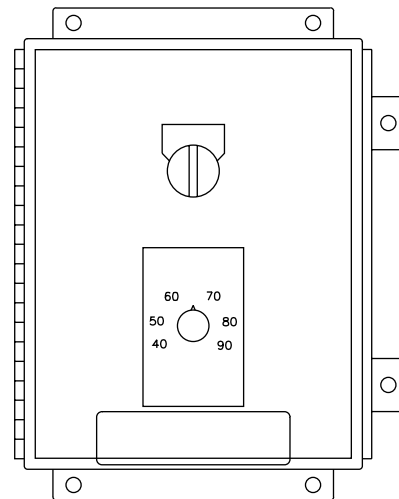

Three-Way Elementary Wiring Diagram

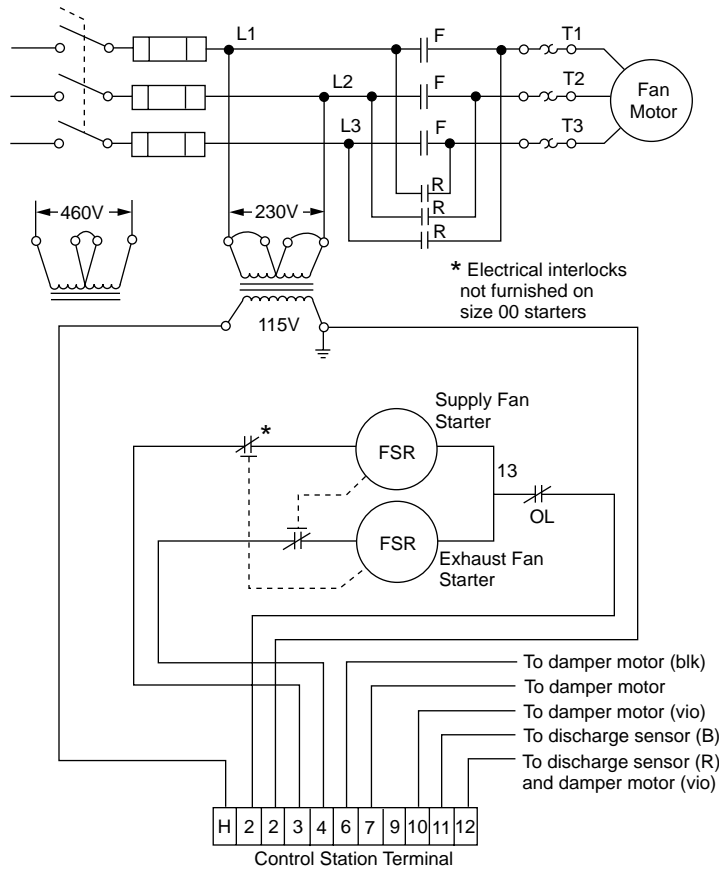

Two-Way Elementary Wiring Diagram

The Two-Way Heat Saver is designed to recirculate 100% or exhaust. The recirculation dampers and exhaust dampers are automatic. The operation is changed by reversing the rotation of the fan/motor.

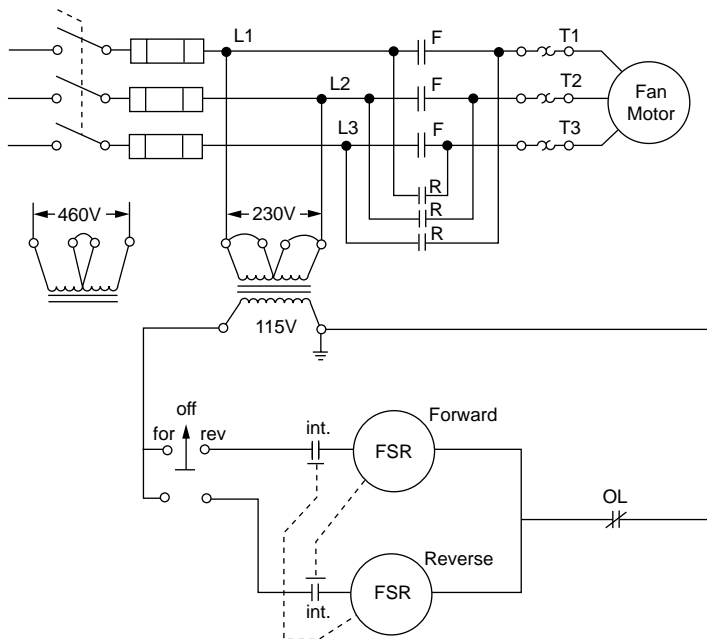

NOTE: The fan must be allowed to stop before the motor rotation is reversed. Do not switch any unit from exhaust to recirculate or supply without allowing the fan blades to stop rotating.

Care and Maintenance

A regular and systematic inspection of all fan parts is the key to good fan maintenance. The frequency of inspection should be determined by the severity of the atmospheric conditions. Components requiring service are generally the moving parts of the fan assembly. They include the following:

PROPELLER: The propeller in an axial flow fan must be kept reasonably clean if it is to perform properly. Fans handling fresh air for ventilating purposes will seldom need cleaning. Fans exhausting process air should be cleaned as required.

SHUTTERS: Periodically check damper blades and remove dirt accumulation. Bronze damper bearings should be checked for smooth operation.

SCREWS AND BOLTS: Check for tightness throughout the assembly.



Aerovent

A Twin City Fan Company

5959 Trenton Lane · Minneapolis, MN 55442-3238
Phone (612) 551-7500 · Fax (612) 551-7501 · www.aerovent.com

