

MODEL ATA & ATABD TUBEAXIAL FANS

1.0 GENERAL DESCRIPTION

Model ATA and ATABD axial fans come in various configurations that offer flexibility to meet the needs of the end user.

1.2 DEFINITIONS

An axial fan consists of a propeller type impeller, motor driven and ducted or shrouded so that the blades are enclosed to increase operating efficiency.

An adjustable pitch impeller is one where the blade angle can be changed, but only when the propeller is stationary.

1.3 Arrangements

Fans are available in two different configurations, defined as follows:

Arrangement 4 (ATA) — The impeller is mounted directly on the motor shaft with both motor and impeller enclosed in the fan case.

Arrangement 9 (ATABD) — The impeller is mounted on a bearing-supported shaft, belt driven by a motor supported on the fan case.

1.4 APPLICATION

Fans can be installed in a free inlet or ducted inlet application. Mounting arrangements include legs for floor mounting, flanges for direct duct connections or brackets for vertical or horizontal mount from the floor or ceiling.

1.5 ACCESSORIES

The following accessories are available on Model ATA and ATABD fans.

- Inlet bell
- Inlet screen
- Inlet and outlet cones
- Companion flanges
- Flexible connectors
- Vibration isolators
- Radial inlet vane dampers
- Backdraft dampers

1.6 OPTIONS

- Legs for horizontal floor mounting
- Clips for horizontal ceiling suspension
- Brackets for vertical floor or suspension mounting

1.6 NAMEPLATE NOMENCLATURE

The model number information on each fan nameplate is explained in Figure 1.

Figure 1.

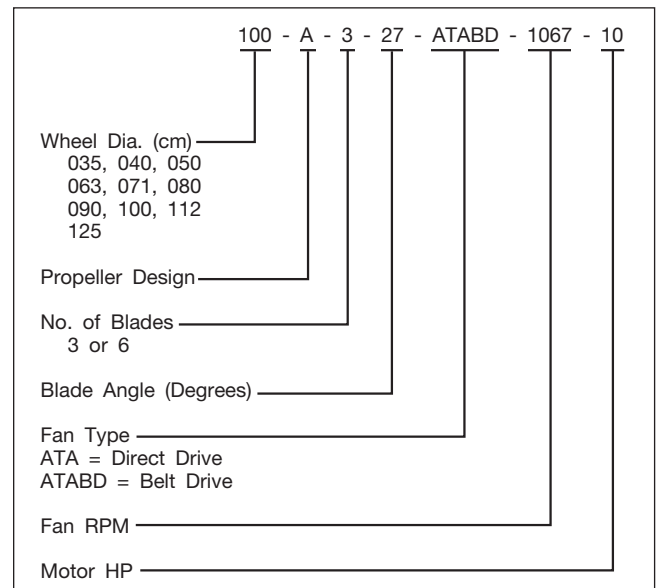

2.0 INSTALLATION

2.1 RECEIVING/INSPECTION/STORAGE

All fans are shipped on wooden pallets. Each fan is normally covered with plastic for weather protection. The fan should remain on the pallet and covered or protected from the weather until installation.

Carefully inspect the fan upon arrival for damage incurred during shipment. Immediately report any damage to both the factory and the carrier. For short-term storage, prior to installation, the fan should remain covered with plastic wrap on the shipping pallet and stored in a clean, dry location away from the elements. If storage is to be for a period longer than six (6) months, consult factory for long-term storage instructions.

2.2 LIFTING

Fans should be lifted using slings. The slings can be placed under the pallet and a spreader bar used as required.

2.3 MOUNTING

Depending on the type of fan support specified, the fan can be floor mounted on legs, supported on a structural frame for vertical airflow or ceiling hung by clip supports or duct mounted.

2.3.1 Vibration Isolators

All fans are dynamically balanced to reduce vibration. However, it is recommended that the fan be supported on vibration isolators. Isolators should be selected for each installation in accordance with individual requirements. Concrete inertia pads are generally not required with ATA and ATABD fans.

2.4 DUCT CONNECTIONS

All fans should be aligned with the ductwork. A flexible connection should be provided between the fan and duct to prevent structure-borne noise from being transmitted to the ductwork.

If the fan is to be attached directly to the duct without a flexible connection, special care must be exercised to align the fan and duct flanges so the fan is not subject to structural loads from the ductwork. These loads could distort the fan housing, causing the blades to hit or rub the case, or change the blade tip to housing clearance and affect performance.

2.5 ELECTRICAL

All wiring should conform to local electrical codes and the job specification. In NEMA standard MG-2, the phenomena of transient torques is addressed. We advise that measures be taken to protect your equipment from transient torque and power interruptions.

2.5.1 Power Connection

The motor leads terminate in the conduit box. The leads are factory connected for the voltage specified for the job. Motor leads for wye-delta and part-winding starts are not connected. Rigid conduit should be run from the motor starter to the fan with a short section of flexible conduit at the conduit box to allow for fan movement.

Wire size and motor overloads should be sized in accordance with the fan nameplate electrical data. The conduit box is located on the outside of the case on all direct driven fans. On belt driven fans the motor is outside the fan case and the connection will be made directly to the motor.

2.5.2 Motor Rotation

Check motor rotation by jogging the motor. The propeller should rotate in the direction indicated by the rotation arrow on the fan case. It is important that correct motor rotation be established on ducted fans as the propeller will not be visible after an inlet duct is installed. Reverse any two motor leads to change direction of rotation of three-phase motors.

2.5.3 Final Check Before Putting Fan Into Operation

1. Check for correct supply voltage and motor overloads.
2. Insure that all loose debris is removed from fan and ducts.
3. Check that the propeller is centered in the fan case and that the blade tip clearance is not less than the minimum values in Figure 2.
4. Hand rotate to assure free movement.
5. Bump the fan starter to check rotation.
6. Start the fan and verify that the vibration levels are satisfactory.
7. Check the current draw. Do not exceed the full load amperage as specified on the nameplate.

Figure 2.

NOMINAL FAN SIZE	BLADE TIP CLEARANCE (INCHES)		
	MINIMUM	NOMINAL	MAXIMUM
035	.028	.063	.098
040	.032	.071	.110
050	.039	.087	.134
063	.047	.110	.173
071	.055	.126	.197
080	.063	.142	.220
090	.079	.177	.276
100	.079	.177	.276
112	.098	.217	.335
125	.098	.217	.335

3.0 FAN BLADE ADJUSTMENT

3.1 GENERAL

Models ATA and ATABD feature an adjustable pitch propeller. The blade pitch has been factory set to meet the airflow requirement of the job specification. If required, the pitch may be changed to meet other airflow requirements on the job site. Contact the factory for recommended new setting and request an AXIPAL blade protractor.

NOTE: If the blade angle is reduced by more than five (5) degrees from the value preset on delivery, the clearance between the blades and the casing will be reduced. Check that the blade tip clearance is not less than the minimum values in Figure 2. If the blade angle is increased, check the tip clearance for minimum clearance as the leading and trailing tips will get closer to the fan casing.

4.0 MAINTENANCE

4.1 GENERAL

ATA and ATABD fans are a quality product designed and manufactured for minimum maintenance and long operating life. They should provide years of trouble-free service if the following maintenance procedures are followed.

There are no moving parts in the propeller assembly. Therefore, routine maintenance is generally limited to motor lubrication, bearing lubrication of the belt driven models and belt replacement.

4.2 FAN BALANCE

The propeller assembly shall be statically and dynamically balanced in accordance with ANSI/AMCA 204-96 "Balance Quality and Vibration Levels for Fans" to Fan Application Category BV - 3, Balance Quality Grade G6.3. In addition, direct drive fan propellers shall be balanced on the motor shaft after final assembly in the fan casing, in the manufacturing facility, to the following peak velocity values, filter-in, to the fan test speed:

Fan Application Category	Rigidly Mounted (in./s)	Flexibly Mounted (in./s)
BV-3	0.15	0.20

4.3 LUBRICATION

4.3.1 Motor Lubrication

Motor bearings do not require initial lubrication unless the fan has been in storage over six months. If this is the case, the motor should be lubricated initially.

Lubricate motor bearings with grease gun at the following intervals and numbers of strokes:

HORSEPOWER	PERIOD	STROKES (SEE NOTE)
5 to 7½	12 Month	1
10 to 40	6 to 12 Month	3
50 to 150	6 Month	3

NOTE: Normal amount of grease delivered by a hand cartridge type grease gun. Remove the purge plug when equipped. Grease does not have to purge from the purge plug, but the purge plug should be removed to release pressure. The grease fittings should be cleaned before attaching the grease gun to prevent contamination.

Use only the following lubricants or their equal:

Polyrex EP2	Alvania No. 2
Chevron SRI-2	Mobil Grease #77
Precision No. 2	Starfak H, M and No. 2
Mobilux No.2	Texaco Premium RB

CAUTION: Do not over lubricate bearings or use a grease other than specified.

4.3.2 Shaft Bearing Lubrication

Model ATABD belt driven fans are equipped with bearing grease leads extending to fittings on the outer surface of the fan casing. The bearings are lubricated at the factory. Lubrication is not required unless the fan has been in storage for more than six (6) months.

Bearings should be lubricated every six (6) months for continuous duty fans, and every six (6) to twelve (12) months for noncontinuous duty fans.

The bearings should be lubricated with the fan in operation.

Lubricate the bearings with a hand cartridge type grease gun applying three (3) strokes per bearing.

Standard lubricants do not apply to fans operating at temperatures above 275°F. Consult factory for high temperature applications.

4.4 BELT REPLACEMENT

In the event of belt failure, it is recommended that the belts be replaced with a complete new set of matched belts. Do not mix old and new belts. The old belt will be longer and the entire load would be carried by the new belt. For replacing belts, follow the procedure outlined below:

1. Loosen the motor base adjusting nuts to move the motor in towards the fan case.
2. Remove old belts.
3. Slip new belts in place.
4. Adjust the motor base to tighten the belts just enough to prevent slippage; any tighter could cause premature bearing failure. After the first thirty-six (36) hours of operation the belts should be checked. If required, tighten the belts to take up the initial stretch. After the initial stretch, only periodic checking will be necessary.

4.5 BEARING REPLACEMENT, BELT DRIVEN FANS

In the event of a bearing failure of the drive shaft bearings, we recommend that the entire bearing assembly or pillow block bearings be replaced. To replace the assembly, follow the procedure outlined below.

NOTE: All impeller hardware is metric. All motor, bearing, and drive (sheave, etc.) are U.S. standard.

- a. Loosen the belts by moving the motor towards the fan case.
 - b. Remove the belts.
 - c. Remove the access cover to the belt guard to expose the belt sheave.
 - d. Remove the belt sheave from the drive shaft.
 - e. Remove the impeller.
- NOTE:** Be sure to record the location of the taper lock bushing on the drive shaft. This must be replaced in the proper location to assure the correct impeller placement.
- f. Disconnect the grease lines at the bearing assembly.
 - g. Remove the bearing assembly by removing the mounting bolts.
 - h. Install the new bearings.
 - i. Replace the taperlock bushing on the shaft in the correct location and torque the locking bolt (see Table B).
 - j. Replace the grease lines.
 - k. Install the belt sheave. Proper sheave alignment is critical.
 - l. Replace the belts and tighten.
 - m. Replace the access cover.
 - n. Lubricate the bearings per Section 4.3.2.

4.6 DIRECT DRIVE, IMPELLER REMOVAL AND INSTALLATION

Remove the impeller.

NOTE: Be sure to record the location of the taperlock bushing on the drive shaft. This must be replaced in the proper location to assure the correct impeller location.

Replace the taperlock bushing on the shaft in the correct location and torque the locking bolt (see Table B).

Install the impeller on the taperlock bushing and torque the mounting bolt (see Table C).

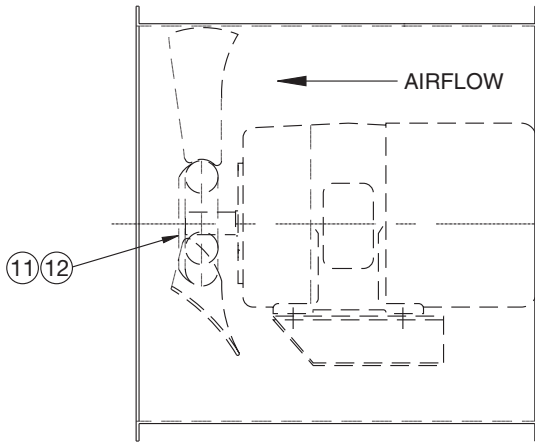

**FIGURE 5
DIRECT DRIVE**

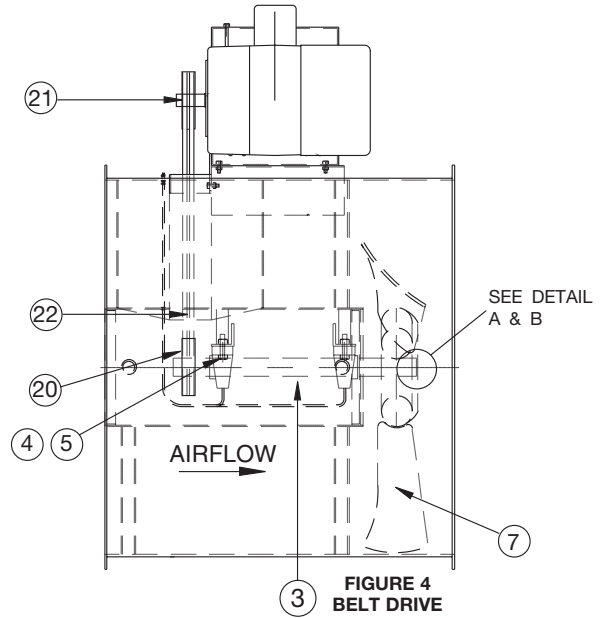

**FIGURE 4
BELT DRIVE**

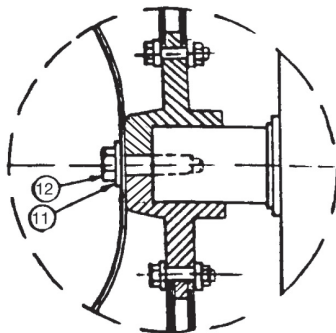

DETAIL A
SIZES 035, 040, & 050

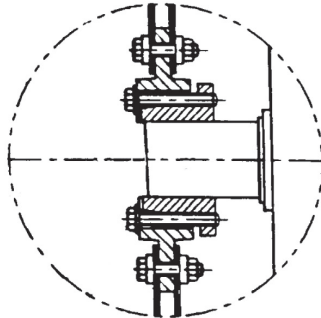

DETAIL B
SIZES 063, 071, 080,
090, 100, 112 & 125

- 3. SHAFT & BEARING ASSEMBLY
- 4. WASHER LOCK
- 5. SCREW - M8X25
- 7. IMPELLER ASS'Y
- 11. WASHER, FLAT
- 12. SCREW, HEX HD.
- 20. SHEAVE, DRIVEN
- 21. SHEAVE, DRIVER
- 22. BELT, DRIVE

TABLE C. ROTOR BOLT #12

FAN SIZE	TORQUE
035, 040, & 050	156 IN-LBS.

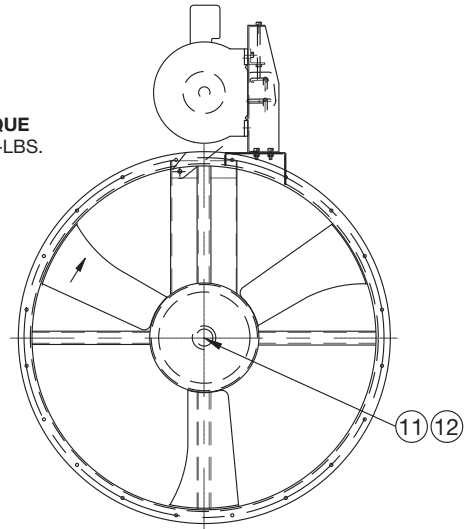

**FIGURE 3
BELT DRIVE**

TABLE B. CAPSCREW TORQUE VALUES

BUSHING NO.	DIAMETER	LENGTH (IN.)	TORQUE FT. LBS.
H	¼-20	1¼	7½
P-1	⅝-18	1½	13
P-2	⅝-18	1¾	13
Q-2	¾-16	2½	24
R-2	¾-16	3	24



Aerovent

A Twin City Fan Company

5959 Trenton Lane · Minneapolis, MN 55442-3237
Phone (763)551-7500 · Fax (763)551-7501 · www.aerovent.com

