

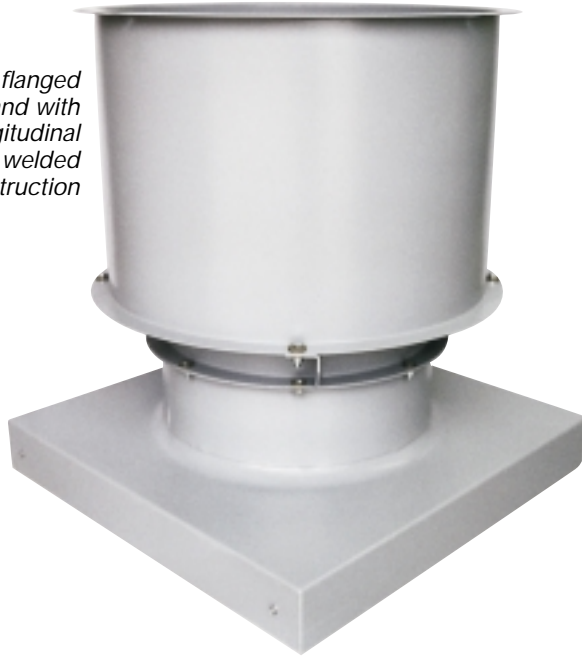

14 gauge flanged
wind band with
longitudinal
seam welded
construction



Model 53 Roof Ventilator
shown with stack cap

Aerovent's Industrial-Duty Stack Cap Provides Four Lines of Defense Against Water Penetration

- ✓ **Wind Band** positioned to prevent wind gusts from lifting dampers.
- ✓ **Splash Guard** protects against the entry of rain by overlapping the damper pivot area.
- ✓ **Throat and Damper Lids** are sloped 5 degrees to guarantee proper water drainage.
- ✓ **Drain Channel** located below the damper pivot area, the final provision against rain entry.

Mechanical Features

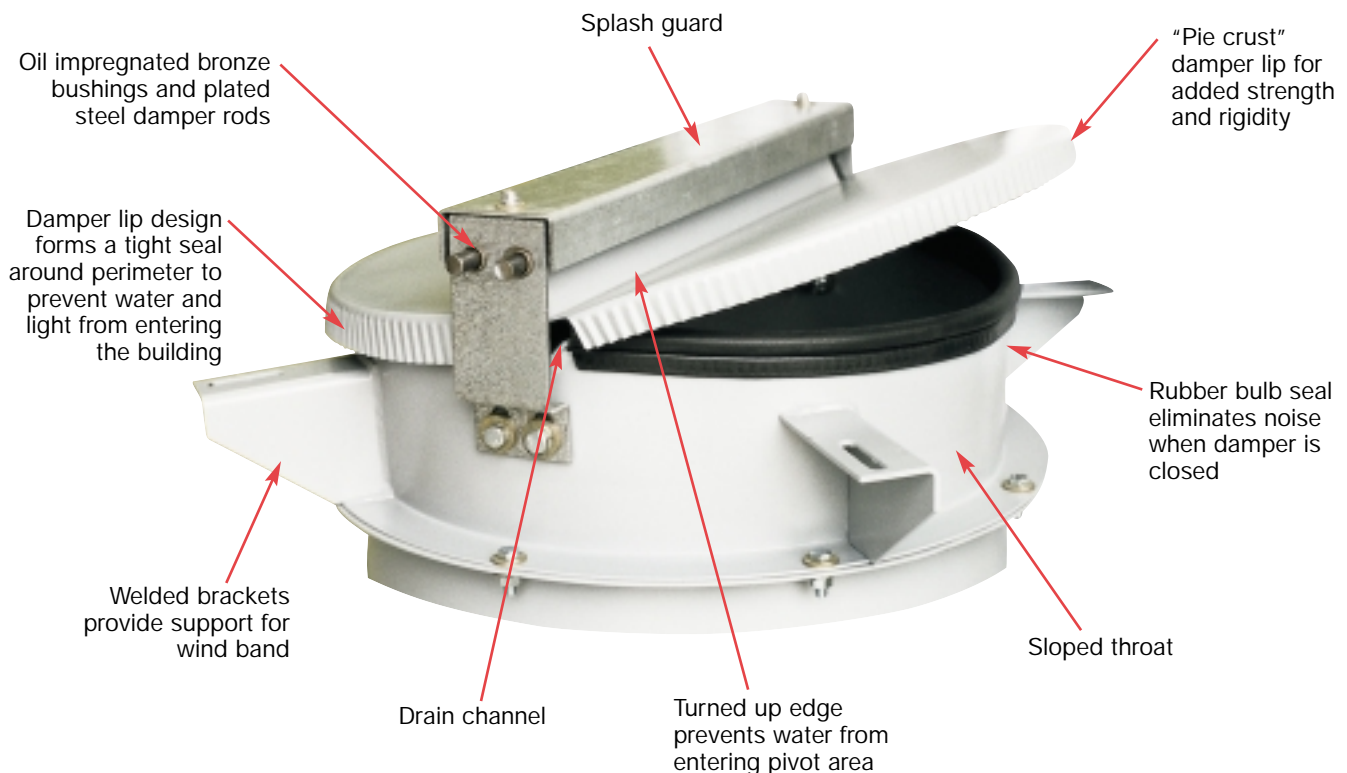

Dimensional Data

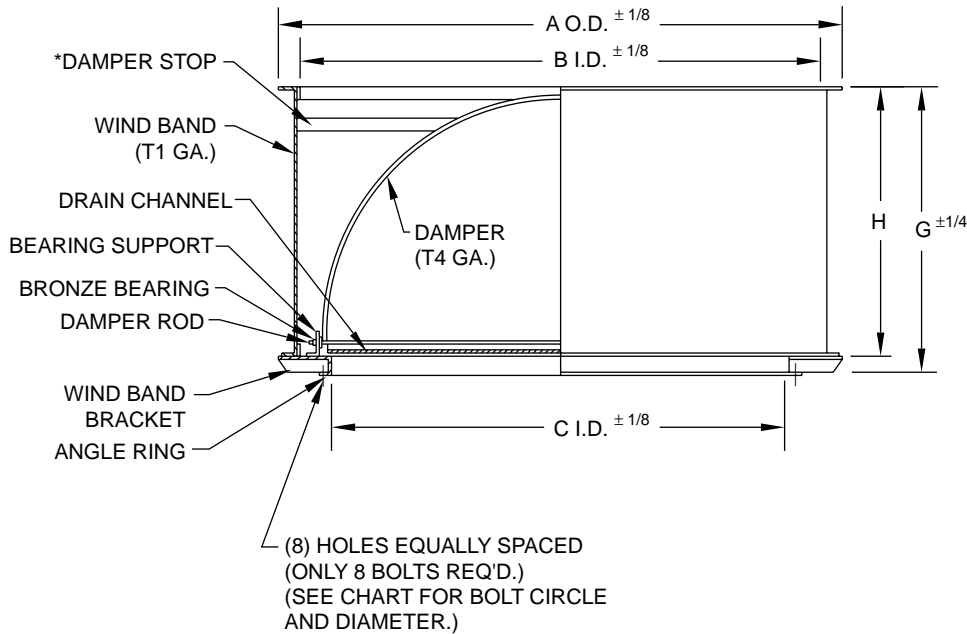

*Rubber cushioned damper stop designed so dampers will close when fan is de-energized.

SIZE	DIMENSIONAL DATA							GAUGES			MIN. CFM REQ'D. TO OPEN DAMPER		MAX. CFM
	A	B	C	G	H	BOLT CIRCLE	HOLE DIA. OR SLOT	STEEL	ALUM.	STEEL	ALUM.		
								T1	T4			T4	
12	21¼	18¾	12¼	16⅝	13	13⅞	1⅛	14	24	.032	1390	1065	2450
14	23¼	20¾	14¼	17⅝	14	15⅞	1⅛	14	24	.032	1885	1440	3320
16	25¼	22¾	16⅞	18⅝	15	17⅞	7/16	14	24	.032	2450	1875	4315
18	28¼	25¾	18¾	21⅝	18	19⅞	7/16	14	24	.032	3130	2395	5525
21	29¾	26⅞	21¼	23⅝	20	22⅞	7/16	14	24	.032	4190	3205	7390
24	31¾	28⅞	24¼	24⅝	21	25⅞	7/16	14	24	.032	5455	4170	9625
30	39¾	36⅞	30⅞	27⅝	24	32	7/16	14	20	.050	8520	6515	15035
36	45¾	42⅞	36¾	30⅝	27	38⅞	9/16	14	20	.050	12525	9580	22100
42	51¾	48⅞	42⅞	33⅝	30	44⅞	9/16	14	20	.050	16850	12885	29730
48	57¾	54⅞	48⅞	36⅝	33	50⅞	9/16	14	20	.080	21950	16765	38690
54	64	60¾	54⅞	39⅝	36	57¼	9/16	14	20	.080	27670	21160	48825
60	70	66¾	60⅞	43⅝	40	63¼	9/16	14	20	.080	34880	26050	60140
72	88	84¾	72¾	49⅝	46	75¼	1⅛	14	20	.080	49050	37510	86555
84	100	96¾	84¾	56⅝	53	88¼	1⅛	14	20	.080	66565	50905	117460
96	112	108¾	96¾	63⅝	60	100¼	1⅛	14	20	.080	86750	66340	153080

NOTE: Flange construction is standard on steel sizes 12 through 60. Angle ring construction is standard on steel wind bands, sizes 72 through 96, and on all aluminum stack caps.

For existing stacks, a companion flange is available for matching cap to stack. Please note minimum and maximum CFM required to open dampers.



Aerovent

A Twin City Fan Company

5959 Trenton Lane · Minneapolis, MN 55442-3237
Phone (763) 551-7500 · Fax (763) 551-7501 · www.aerovent.com



MEMBER