



ENGINEERING DATA

Aerovent • TC Ventco • Fiber-Aire • Twin City Fan & Blower • TC Axial • Clarge

Integral AC Motor Selection and Application Guide For Fans

Introduction

This discussion will focus on 3-phase asynchronous induction motor selection. Because of the simplicity of operation, ruggedness of construction and low maintenance, these are the most commonly used motors for industrial fan applications having power requirements of one horsepower or greater.

AC Motor Construction

Shown in Figure 1 is a cutaway view of a typical AC induction motor with the components labeled and the overall assembly indicating the simplicity of construction. Note that there are only two wearing parts – the two bearings. There are no other sliding surfaces such as commutators, brushes or collector rings.

Figure 1. Cutaway View of a Typical AC Induction Motor

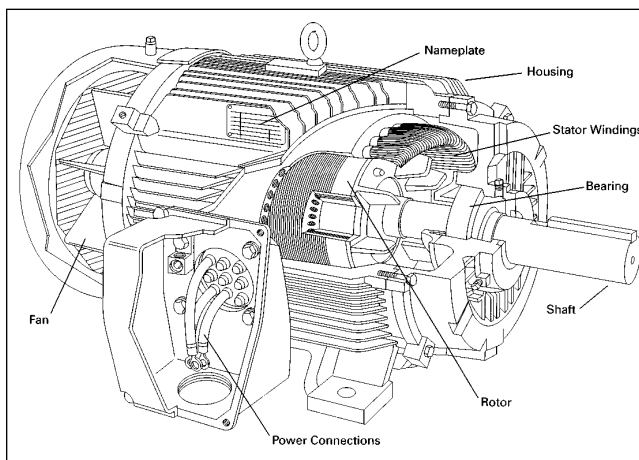

There is a broad range of types and sizes of motors manufactured and naturally not all are manufactured the same way, but they all incorporate the following similar basic components.

Stator Assembly

Stator laminations are punched out of magnetic steel and stacked to a predetermined depth, compressed and welded together, or bound together by a series of locking bars. The stator windings and insulation components are then placed in the stator core, secured and the complete stator assembly is thoroughly impregnated with multiple dips of varnish.

Rotor Assembly

A series of rotor laminations (usually made from the center of the stator laminations) is placed in a die-casting machine where molten aluminum is forced into the die. The resulting homogeneous assembly now includes the rotor conductors, end rings and blower fins. A machined shaft is pressed into

the rotor assembly, placed into a lathe and the shaft ends, and rotor diameter machined to their final dimension. Finally the complete assembly is balanced and bearings are pressed on each end of the shaft.

Frame and Assembly

The stator assembly is pressed into a steel or cast iron frame, the rotor assembly is placed inside the stator and the end brackets added. The motor is completed with the addition of the conduit box, painting and nameplate installation.

Fundamentals

There is nothing mysterious about the 3-phase, asynchronous induction motor. All that is required to understand it is common sense and some knowledge of the fundamentals.

NEMA Standards

All manufacturers of integral electric motors support and comply with NEMA (National Electrical Manufacturers Association). NEMA's standards govern certain important items common to all motors such as:

- HP (horsepower ratings)
- RPM (speed)
- Frame sizes and dimensions
- Standard voltages and frequencies
- Service factors
- Torques
- Starting current (amps) and KVA
- Enclosures
- Balance level

What this provides is the assurance that a motor purchased from any manufacturer will comply with the user's requirements without modification. One word of caution, however: NEMA does not control the motor stack length (overall axial length from end of shaft to end of motor). Although most motor manufacturers' overall lengths are reasonably close there is the reality that in some cases this length can vary as much as 2 to 3 inches.

Where space is critical, particularly in replacement situations, procuring a specific manufacturer's motor may be required.

Voltage and Frequency

The nominal 3-phase, 60 cycle (Hz) power system voltages commonly available in the United States for industrial plants are 208, 240, 480 and 600 volts. The utilization (motor nameplate) voltage is set at a slightly lower level to allow for voltage drop in the system between the transformer and motor leads. Typically the motors are nameplated for 200, 230, 460 and 575 volts.

While rarely required in the United States and Canada, 50 Hz is the prevailing frequency in Europe and Asia. The nominal 3-phase, 50 Hz power system voltages vary from country to country. Therefore, motor voltage should be selected

for the country in which it will operate. The preferred 50 Hz motor voltages are 190, 380 and 440 volts and they cover most nominal system voltages.

Although motors built for 50 Hz are becoming more readily available in the U.S., consideration should be given to the accepted practice of derating 60 Hz motors. A 60 Hz motor may be successfully operated at 50 Hz at reduced horsepower and voltage as shown in the following table.

Table 1. Derating Values for 60 Hz Motors

60 Hz VOLTAGE	50 Hz OPTIONAL VOLTAGE RATINGS (±5%)		
	190	200	210
230	190	200	210
460	380	400	420
575	440	500	525
DERATE FACTOR	0.85	0.80	0.75

Rated HP at 50 Hz = Nameplate HP x Derate Factor

Allowable voltage variation at derated HP = ±5%

Select motor overload protection for 60 Hz amps and 1.0 service factor.

Motor speed = 5/6 nameplated rated speed

Service factor = 1.0

These motors should be ordered as 60 Hz motors with no reference to 50 Hz.

NEMA standards state that motors must be able to carry their rated horsepower at nameplate voltage ±10% although not necessarily at rated temperature. Occasionally we see a motor rated at 208-230/460 volts. Using this motor on a 208 volt system means that the network must have very good regulation. For instance, a 230 volt motor applied at 208 volts (90% of rated) loses any service factor indicated on the nameplate and could run hotter than at rated voltage. A motor used on a 208 volt system should be ordered as a 200 volt motor with winding and nameplate so designed and stamped.

Voltage and Frequency Variation

Motors are designed to operate successfully with limited voltage and frequency variations. Voltage variation with rated frequency must be limited to ±10% and frequency variations with rated voltage must be limited to ±5%. The combined variation of voltage and frequency must be limited to the arithmetic sum of 10%. Variations are expressed as deviation from motor nameplate values, not necessarily system nominal values. The allowable ±10% voltage variation is based on assumptions that horsepower will not exceed nameplate rating and that motor temperature may increase.

The following conditions may occur with variations in voltage (see Figure 2).

1. An increase or decrease in voltage may result in increased heating at rated horsepower load. Under extended operation this may accelerate insulation deterioration and shorten motor insulation life.
2. An increase in voltage will usually result in a noticeable decrease in power factor. Conversely, a decrease in voltage will result in an increase in power factor.
3. Locked-rotor and breakdown torque will be proportional to the square of the voltage. Therefore, a decrease in voltage will result in a decrease in available torque.
4. At full load an increase of 10% in voltage will result in a 17% reduction of slip. A decrease of 10% in voltage will increase slip approximately 23%.

Figure 2. Percent Voltage Variation

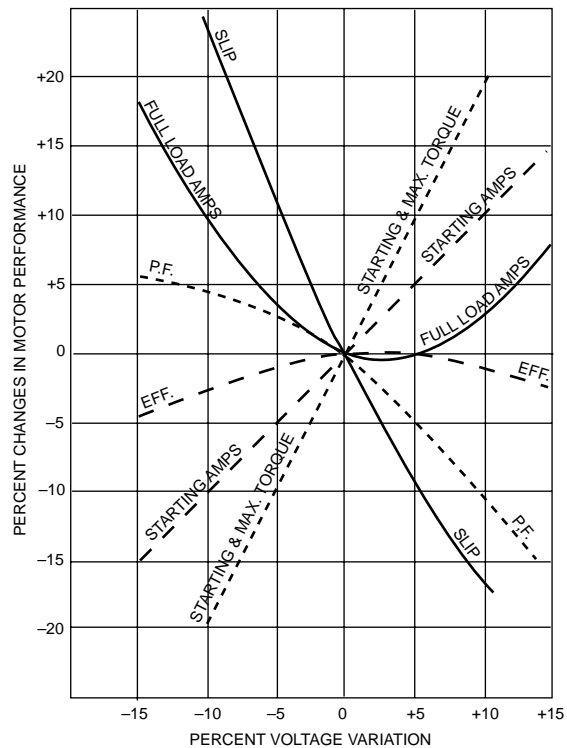

The following conditions may occur with variations in frequency (see Figure 3).

1. Frequency greater than rated frequency normally improves the power factor but decreases locked-rotor and maximum torque. This condition also increases speed and therefore friction and windage losses.
2. Conversely, a decrease in frequency will usually lower the power factor and speed while increasing locked-rotor maximum torque and current.

Figure 3. Frequency Variation

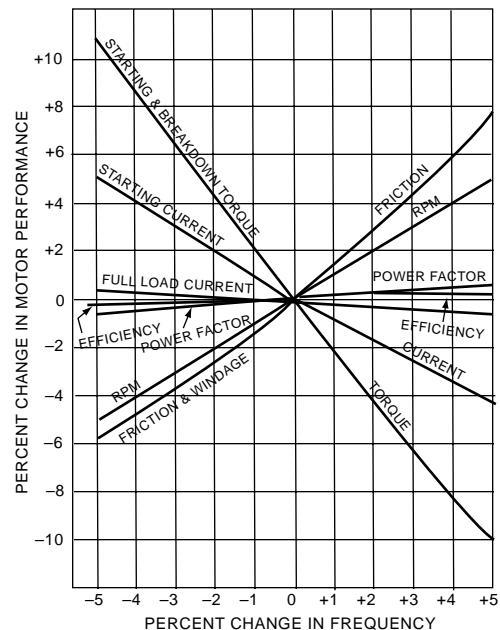

Power Factor

Power factor is an important consideration when selecting a motor for a particular application since low power factor may result in power factor penalty charges from the utility company. Since the power company must supply KVA but normally meters kilowatts used, low motor power factors require additional KVA with low return on kW utilized; hence, power factor penalties.

Unbalanced Voltage

AC 3-phase motors will operate successfully under running conditions at rated load when the voltage unbalance at the motor terminals does not exceed 1%. Performance will not necessarily be the same as when the motor is operating with a balanced voltage at the motor terminals.

When the line voltages applied to a 3-phase induction motor are not equal, unbalanced currents in the stator windings will result. A small percentage voltage unbalance will result in a much larger percentage current unbalance. Consequently, the temperature rise of the motor operating at a particular load and percentage voltage unbalance will be greater than for the motor operating under the same conditions with balanced voltages.

Should voltages be unbalanced, the rated horsepower of the motor should be multiplied by the factor shown in Figure 4 to reduce the possibility of damage to the motor. Operation of the motor above a 5% voltage unbalance condition is not recommended.

Figure 4. Integral HP Motor Derate Factor

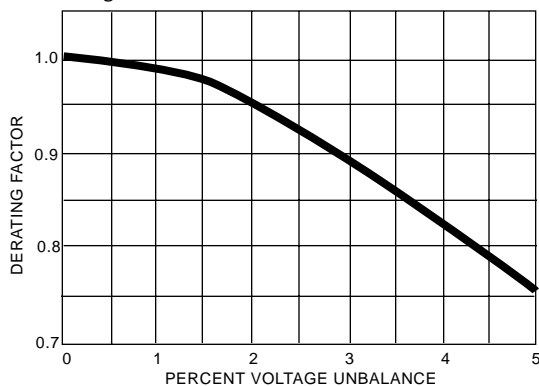

$$\text{Percent Unbalance} = \frac{100 \times \text{Max. Voltage Deviation from Avg. Voltage}}{\text{Avg. Voltage}}$$

Example: With voltages of 220, 215 and 210, the average is 215, and the maximum deviation from average is 5. Therefore, percent unbalance = $(100 \times 5) \div 215 = 2.3\%$

From Figure 4 the motor derating factor is 0.93. Consequently, if we have a 20 HP, 3-phase motor its output should be derated to approximately 18.6 HP to reduce the possibility of damage to the motor.

Unbalanced voltage will produce the following effects on performance characteristics:

Torques — Unbalanced voltage results in reduced locked-rotor and breakdown torques for the application.

Full Load Speed — Unbalanced voltage results in a slight reduction of full load speed.

Current — Locked-rotor current will be unbalanced to the same degree that voltages are unbalanced but locked rotor KVA will increase only slightly. Full load current will be unbalanced in the order of six to ten times the voltage unbalance.

Temperature Rise — A 3.5% voltage unbalance will cause approximately 25% increase in temperature rise.

Efficiency — A marked reduction of motor efficiency will exist because of increased current.

Speed and Slip

The speed of a 3-phase induction motor depends on the frequency and number of poles for which the motor is wound. The higher the frequency, the faster the speed. The more poles the motor has, the slower the speed. The smallest number of poles ever used is two. A two-pole, 60 cycle motor will run at approximately 3600 RPM (unloaded).

To find the approximate speed of any induction motor we can use the formula for synchronous speed which is the speed of the rotating magnetic field:

$$\text{Synchronous Speed (Ns)} = (60 \times 2f) \div p$$

Where f = frequency of the power supply in HZ

p = number of poles for which the machine is wound

Three-phase induction motors are wound for the following synchronous speeds:

Table 2. Induction Motor Speed

NO. OF POLES	60 HZ SYNC. SPEED	50 HZ SYNC. SPEED
2	3600	3000
4	1800	1500
6	1200	1000
8	900	750
10	720	600
12	600	500

Almost all standard commercial motors (143T to 445T frame sizes) are wound with a maximum of 8 poles.

The actual full load speed of an induction motor is somewhat less than its synchronous speed. This difference between synchronous speed and full load speed is called "slip." Percent slip is defined as follows:

$$\text{Percent Slip} = \frac{\text{Sync. Speed} - \text{Nameplate Speed}}{\text{Sync. Speed}} \times 100$$

A typical 5 HP, 4-pole motor has a full load speed of 1750 RPM. Therefore it would have a slip of

$$\frac{1800 - 1750}{1800} \times 100 = 2.8\%$$

The exact slip percentage varies from one motor size and type to another. Slip is also somewhat dependent upon load. A partially loaded motor will run slightly faster than a fully loaded motor. For convenience the following nominal speed table has been established to be used to determine fan performance.

Table 3. Nominal Speeds for 60 Hz Motors

NO. OF POLES	SYNCHRONOUS SPEED (RPM)	NOMINAL SPEED (RPM)
2 POLE: THRU 1 HP 1½ THRU 25 HP 30 HP & UP	3600	3450 3500 3550
4-POLE: THRU ¾ HP 1 THRU 20 HP 25 HP & UP	1800	1725 1750 1770
6-POLE: THRU ¾ HP 5 HP & UP	1200	1150 1175
8-POLE: THRU 1/8 HP 1/2 HP & UP	900	850 875

NOTE: 50 Hz motor speeds can be determined by multiplying the above ratings by 0.833 (50/60).

Multi-Speed Motors

Special multi-speed motors are available in two, three or four speeds. Industrial applications usually only deal with the more common two-speed motors.

Two-Speed, Single Winding Motor — These motors are called “consequent pole” motors. The low speed on a single winding motor is always one-half of the higher speed. If requirements dictate speeds of any other ratio, a two-winding motor must be used.

Two-Speed, Two Winding Motor — These motors must be used when the desired speeds are not in the ratio of 2:1. A separate winding is installed in the motor for each desired speed (e.g., 1750/1160 RPM). Speeds with a 2:1 ratio can be delivered by two-winding motors as well as by single-winding motors.

The choice between one- and two-winding motors is affected by the speeds desired, the motor price, the control price, wiring complexity and physical size. One-winding motors have lower prices than two-winding motors but usually require a higher price control.

Inverter Duty Motor — AC induction motors powered by adjustable-frequency drives are an efficient way to vary fan speed. While almost any induction motor will operate with adjustable-frequency drives, it's a good idea to specify that the motor selected be suitable for use with VFDs. This will help minimize future motor problems. A baseline specification for inverter duty motors is NEMA MG1, Part 31 for insulation capability. However, it's best to select a motor that exceeds this specification because the minimum 1600V peak voltage limitation covered in MG1, Part 31 is often exceeded in real life.

Briefly, the most common speed controls use PWM (pulse width modulated) inverter drives. High carrier frequency (fast switching) is preferred because it generates more pulses resulting in a smoother sine wave which more closely simulates line power. Additionally, motors connected to AC drives produce an audible noise at a tone close to the carrier frequency. Frequencies above 3 kHz make this noise less discernible to humans and above 10 kHz it can't be heard at all. The downside is that the high carrier frequencies tend to result in a buildup of voltage which far exceeds the motor nominal operating voltage. These voltage spikes not only break down the motor insulation, they also create a corona discharge across any small voids in the system thus generating ozone which is an aggressive oxidizing agent that causes further degradation of the insulation.

These higher voltage spikes also cause the stator to induce an electrical charge to the rotor. This electrical charge passes to the motor shaft and into the support bearings. At this point it discharges across the grease-filled gap between the balls and outer race of the bearing, often producing pitting and fluting in the race.

Inverters For Underspeed Considerations — Typically inverters are used on direct drive fan applications and are sized for the full load (HP) condition. Where a higher speed motor, when compared to fan running speed, is specified care must be exercised in selecting the correct size motor and drive.

For example, a direct driven fan selected for 600 RPM requires 12.8 BHP to meet a specified condition of flow and pressure. An 1160 RPM motor has been specified for this application to be used in conjunction with a customer supplied inverter drive. AC motors running on an AC line operate with a constant flux (ϕ) because the voltage/frequency ratio is constant. Motors operated with constant flux are said to have constant torque. An AC drive is capable of operating a motor with constant flux from approximately 0 Hz to the motor nameplate frequency (typically 60 Hz). This is the constant torque range. Therefore, because $HP =$

$(\text{Torque} \times \text{RPM}) \div 5250$, holding torque constant, then HP varies directly as the speed. So from our example:

$$\frac{600}{1160} \times \text{HP} = 12.8$$

$$\text{or the required motor HP} = 12.8 \times \frac{1160}{600} = 24.75$$

A 25 HP, 1160 RPM motor is required.

This example refers to direct drive applications only. For a V-belt driven fan, a 15 HP motor (1800 RPM or 1200 RPM) will suffice.

Inverters For Overspeed Considerations — Some applications require the motor to operate above its full load speed. An adjustable speed drive can operate at frequencies well over 60 Hz, permitting the higher RPMs. However, there is some risk involved. First of all, excessive speeds can damage the rotor, fan or bearings and the bigger the motor the greater the risk. Second, consideration must be given in sizing the motor. Unfortunately, voltage cannot be higher than motor nameplate voltage. Therefore, if the voltage remains constant flux will decrease because the voltage/frequency ratio decreases. This then will result in a decrease in torque. Above 60 Hz the motor horsepower remains constant as speed increases and torque decreases in proportion. So above 60 Hz:

$$\text{HP (constant)} = \frac{\text{Torque (decrease)} \times \text{RPM (increase)}}{5250}$$

The motor must be sized for the anticipated speed increase. For example, a direct drive fan operating at 1160 RPM and 60 Hz requires 10 BHP. If the anticipated fan speed increase is 1334 RPM the corresponding frequency would be 69 Hz. Therefore, the motor must be sized for $(69/60)^3 \times 10 = 15.2$ BHP.

Rotation — The direction of a 3-phase induction motor depends on the motor connection to the power lines. Rotation can be readily reversed by interchanging any two input leads to match the fan rotation.

Service Factor — The service factor is a percentage multiplier applied to the nameplate horsepower to obtain continuous overload capacity of the motor.

Thus a standard dripproof 10 HP motor rated with a 1.15 service factor at 40°C ambient could carry a continuous load of 1.15 SF x 10 HP or 11.5 HP.

Integral open dripproof and totally enclosed fan cooled motors usually have a service factor of 1.15 while explosion proof motors usually have a 1.0 service factor. It is important to remember that the value obtained by applying a service factor is valid only if usual service conditions, rated voltage, 40°C ambient, and rated frequency are maintained.

Insulation — NEMA has established insulation classes to meet motor temperature requirements found in different operating environments. The four insulation classes are A, B, F and H. Class F is the most commonly used while Class A is seldom used. Before a motor is started its windings are at the temperature of the surrounding air. This is known as “ambient temperature.” NEMA has standardized on an ambient of 40°C or 104°F for all motor classes. The most common insulation classes are shown below.

Table 4. Common Insulation Classes

INSULATION CLASS	AMBIENT TEMPERATURE RANGE	HOT SPOT TEMPERATURE
B	Up to 40°C (104°F)	130°C (266°F)
F	41°C (105°F) to 65°C (149°F)	155°C (311°F)
H	66°C (150°F) to 90°C (194°F)	180°C (356°F)

Not all parts of the motor windings operate at the same temperature. The temperature at the center of the coil is the

hottest and is referred to as the “hot spot temperature.” The hot spot temperature is the basis for establishing the insulation class rating.

Ambient Temperature — It’s best to select a motor with the appropriate insulation for the specific ambient conditions. For example, a TEFC motor with Class F insulation is suitable for ambient temperatures of 40°C (104°F) with a service factor of 1.15. That same motor can be operated to 65°C (149°F) with a service factor of 1.0. Operating this motor above these limits will reduce its life expectancy. A 10°C increase in the ambient temperature to 75°C (167°F) can decrease the motor’s life expectancy as much as 50%.

Motor Enclosures

For proper application, the selection of the type of enclosure to employ is quite important in order to meet the particular atmospheric conditions.

There are two broad enclosure classifications: Open and Totally Enclosed. Each is divided into a number of specific types. The primary types are as follows:

Open	Totally Enclosed
Dripproof	Non-ventilated
Splash proof	Fan-cooled
Weather protected	Explosion proof
	Air over
	Waterproof
	Heat exchanger

Only those most frequently used are covered in this guide.

Dripproof (ODP) — This motor has ventilation openings which permit the passage of ambient air over the rotor and windings. The openings are constructed so as to prevent drops of liquids or solid particles falling at any angle from 0 to 15 degrees downward from vertical from entering the motor.

These motors are typically used in relatively clean, dry, mild humidity indoor applications. They are not usually suited for wet, outdoor duty unless protected.

Totally Enclosed — Totally enclosed motors are designed to prevent the free exchange of air between the inside and outside of the enclosure, but not sufficiently enclosed to be airtight. The ones most commonly used are:

TEFC – Totally Enclosed Fan Cooled: This type includes an external fan mounted on the motor shaft. The fan is enclosed in a fan casing which both protects the fan and directs the air over the motor frame for cooling. The TEFC motor is used in indoor or outdoor duty applications where dust, dirt, mild corrosives, and water are present in modest amounts.

TEAO – Totally Enclosed Air Over: This type is similar to the TEFC design except that the cooling fan and casing are not provided. This motor is not self-cooling. It should only be used in applications where the fan itself provides sufficient airflow over the motor surface for cooling.

FCXP – Fan Cooled Explosion Proof: This is a totally enclosed motor designed and built to withstand an explosion of gas or vapor within it, and to prevent ignition of dust, gas, or vapor surrounding the machine by sparks, flashes or explosions which may occur within the motor casing.

The National Electric Code categorizes common hazardous atmospheres and locations. Since the type and degree of hazard varies widely according to the materials encountered and their presence in hazardous quantities, the following methods of identification are used:

- CLASS – Hazardous materials are assigned to three broad categories: gases, dusts, and fibers.

- Class I – A hazardous location in which flammable gases or vapors are present in sufficient quantities to produce an explosive mixture.
- Class II – A hazardous location in which flammable dusts are present in sufficient quantities to produce an explosive mixture.
- Class III – A hazardous location in which ignitable fibers or combustible flyings are present in sufficient quantities to produce an explosive mixture. There is no group designation for this class. An example would include cotton and rayon in textile mills.
- GROUP – Hazardous materials (gases, dusts, fibers) grouped according to their relative degree of hazard.
- Class I, Group A – Atmospheres containing acetylene.
- Class I, Group B – Atmospheres containing hydrogen, or gases or vapors of equivalent hazards such as manufactured gas.

Explosion proof equipment is generally not available for Class I, Groups A and B, and it is necessary to isolate motors from the hazardous area.

- Class I, Group C – Atmospheres containing ethyl, ethylene or cyclopropane vapors.
- Class I, Group D – Atmospheres containing gasoline, hexane, naphtha, benzene, butane, alcohol, acetone, benzol, lacquer solvent vapors or natural gas.
- Class II, Group E – Atmospheres containing metal dust.
- Class II, Group F – Atmospheres containing carbon black, coal or coke dust.
- Class II, Group G – Atmospheres containing flour, starch or grain dust.
- DIVISION – Separates hazardous locations into two categories based on whether the hazardous material (gas, dust, fiber) is present under normal operating conditions or only under extraordinary circumstances.
- Division I – Hazard exists under normal operating conditions. (Motor must be explosion proof.)
- Division II – Hazard exists only during abnormal circumstances. (Article 501 of the National Electric Code states that in Division II locations, “The installation of open or non-explosion proof enclosed motors such as squirrel cage induction motors without brushes, switching mechanisms, or similar arc-producing devices shall be permitted.”)

Caution: The responsibility of specifying the proper Class, Group, and Division of a hazardous location resides with the ultimate user and the involved regulatory agency.

Motor Starting Methods

Full Voltage Starting – This is the most common and least expensive starting method for induction motors and does not require any special construction. All standard motors are designed for full voltages (across-the-line) starting. The down side is that the high inrush current (six to nine times the running current) required to come up to speed sometimes causes premature tripping of overload breakers, particularly when accelerating high inertia loads which are common in fans.

Auto Transformer Starting – Employs auto transformers to directly reduce voltage and current on start-up. After a pre-set time interval the motor is connected directly across the line. The most commonly furnished taps on auto transformers are 50, 65 or 80 percent of full voltage. This is the most expensive method but no special motor winding is required.

Wye-Delta Starting – Sometimes call “Star Delta,” this method impresses the voltage across the Y connection to reduce the current on the first step, and after a preset time interval the motor is connected in delta permitting full current. This method requires a motor winding capable of wye-delta connection. It may fail to accelerate high inertia loads.

Part Winding Starting – Requires a special motor with two separate winding circuits. Only one winding circuit is energized on startup. After a preset time interval the full winding of the motor is put directly across the line. This method may fail to accelerate high inertia loads. A standard dual voltage motor (230/460) can be used but only if the lower voltage is used.

These last three starting methods are commonly referred to as reduced voltage starting. They all require special starters designed for the particular method and are controlled between the start and run functions by an adjustable timer.

Types of Mountings

The Frame – Includes the mounting feet and forms the foundation for the complete assembly. This is commonly referred to as a “T” frame motor and it can be positioned in any plane – top, bottom, or side.

The Conduit Box – Can be located on either side of the frame. The standard location of this box is on the right side of the motor when viewed opposite the shaft end, and is referred to as an “F-1” motor. The opposite location is referred to as “F-2”.

NEMA lists twelve standardized assembly combinations and has assigned code designations as shown below.

Figure 5. Conduit Box Mounting Locations

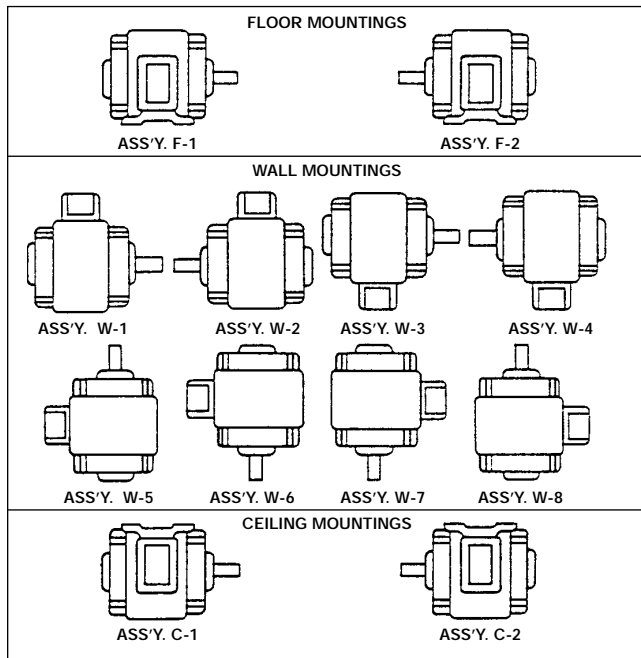

F-1 is most commonly used on the majority of fan applications, regardless of fan arrangement, mostly because of availability. Unless otherwise specified, NEMA assembly F-1 will be provided.

Bracket Mountings – Motors are also available with special machined end shields: Type C-face and Type D-flange. These are shown below.

Figure 6. Type C-face

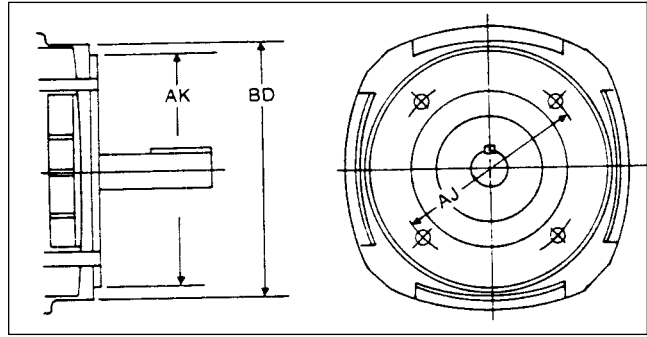
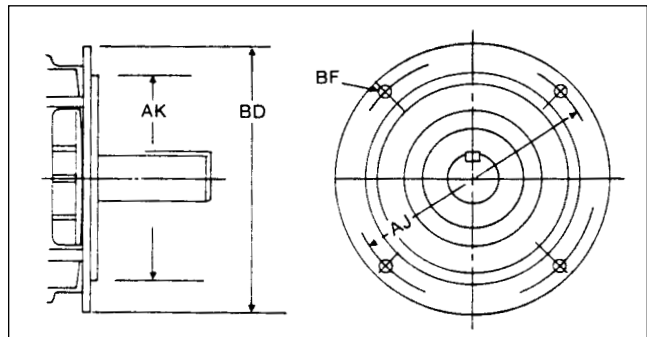

Figure 7. Type D-flange



The Type C-face provides a male rabbet and tapped holes for mounting bolts while the Type D-flange provides a male rabbet and flange holes for through-bolts.

When a face or flange mounted motor is required for a fan application, Type C-face is the motor of choice and it is standardly provided with feet. The Type D-flange motor, when used, is standardly provided without feet.

To avoid confusion, however, either motor when required should be specified with or without feet.

Load Inertia, WK²

It is not always enough to select a motor based on the horsepower requirements of the fan. The motor not only must develop sufficient torque to overcome the fan loads, but is also must have enough excess torque to overcome the inertia of the fan and accelerate it to speed within a required amount of time. Generally speaking, if motors built in frame 447T and smaller can come up to speed in less than 20 seconds, they should be acceptable for fan duty.

Figure 8 represents a fan load curve superimposed on a typical NEMA Design B induction motor speed torque curve.

Figure 8. Fan Load and Motor Speed Torque Curves

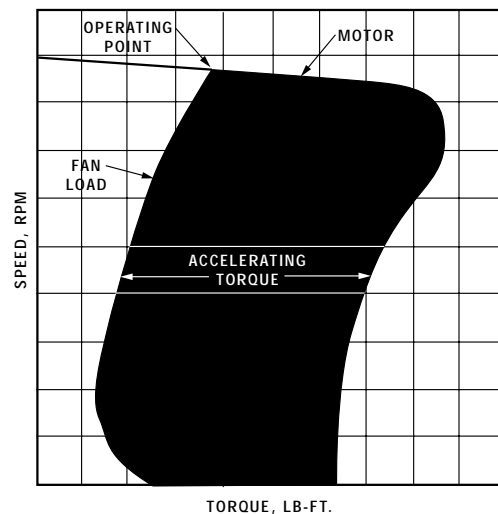

The shaded area represents the accelerating torque available at any speed. Fan speed torque curves are available from the fan manufacturer.

Failure of the motor to attain full speed, or to attain full speed within the required time frame, results in excessive motor temperatures, which lead to premature motor failure.

The fan impeller inertia is referred to as WR^2 . Typically, motor manufacturers refer to the motor inertia as WK^2 . What we're actually looking at is a value of WK^2 (WR^2) which reflects the motor's capability of accelerating a fan type load.

If the motor is direct connected, the impeller inertia (WR^2) may be used as stated in the catalog. If the motor is used to drive the fan through a sheave combination, at either higher or lower speeds than the motor, then it is necessary to calculate the inertia "referred to the motor shaft"; that is, an equivalent inertia based on the speed of the motor.

$$WK^2_{ms} = WR^2_{fs} \left(\frac{N_f}{N_m} \right)^2$$

Where: WK^2_{ms} = inertia of fan load referred to motor speed (lb-ft²)

WR^2_{fs} = inertia of fan load and inertia drives and shaft (lb-ft²)

N_f = Speed of fan (RPM)

N_m = Speed of motor (RPM)

Starting Frequency

Generally speaking, for the majority of fan applications, the duty is continuous over long time periods. There are, however, situations requiring repetitive starts with a given fan load and inertia. Motor selection must take into account the excess heating caused by these conditions.

A motor draws approximately six to nine times the full load current on startup, so resistance losses (current²) during this time are up to 36 to 81 times the losses at full load. If the impeller inertia is low, acceleration will be rapid, which could allow for multiple starts per minute without overheating. On the other hand, if the impeller inertia is high, requiring maximum time to attain speed, starts may be limited to one per hour. Motors used on these high inertia loads should be thermally protected to avoid costly burnouts.

Effect of "EPACT"

With the passage of the Energy Act of 1992, the government mandated that after October, 1997, all general purpose motors must meet nominal full load efficiency levels. EPACT specifically targeted motors with the following characteristics:

- General purpose
- Foot mounted
- Design A & B
- Open and enclosed design
- 3-digit NEMA frame
- T-frame
- Polyphase
- Continuous rated
- 60 Hertz
- 2, 4, or 6 pole
- Single speed
- Squirrel-cage induction
- 230/460 volt
- 1 to 200 HP

This covers all motors sold in the United States, whether domestic or imported. Explosion proof motors are being added to this list effective October, 1999.

While complying with the EPACT standards has the most impact on the motor manufacturers, it also creates some design considerations for applying these motors to fans.

Higher efficiency motors come at an increased cost to the fan manufacturer. A premium efficiency motor can cost 30 to 40 percent more than a general purpose motor. Premium efficient motor design requires larger diameter copper wires which occupy more space. This means larger slots, which reduces the amount of active steel in the laminations. This loss of steel is compensated for by adding additional laminations which increases the length of the rotor and stator coil. Rotor designs are improved, air gap between rotor and stator is reduced, oversized bearings are used, and the cooling fan is redesigned. All these things improve efficiency but add costs.

The higher efficiencies required by EPACT lie somewhere between general purpose and premium duty motors and also come as a somewhat higher cost: 10 to 15 percent.

Associated with these higher efficient motors are some issues which impact the application with both the fan manufacturer and the end user:

1. High efficiency motors draw higher amps during start-up. This may require circuit breakers or starters with higher trip ratings.
2. High efficient motors tend to have less slip, which increases full load speed (RPM). This can cause higher amp draw on direct drive installations due to higher horsepower requirements. Speed increase on belt drive units can affect drive selections.
3. The increase in motor length can cause fit-up problems on some fan designs. Some may require larger diameter frames.
4. Acceleration capabilities of fan type loads may be compromised by lower allowable WK^2 values.
5. High efficient motors tend to run cooler and more efficiently, but to deliver these economies they must be operated between 75% and 100% of rated load operation. Operation below these values may require more electricity than standard motors for the same service.
6. High efficient motors tend to weigh more than standard designs. While this may not have significant impact on our fan designs, it certainly will affect freight charges.

When replacing high efficient motors for older designs the issues mentioned above should be considered.

Conclusion

The information included in this document is intended to provide the designer/agent/user with basic information to aid in the selection and application of integral 3-phase asynchronous induction motors. There are many other considerations for proper motor selection. Additional information may be obtained directly from the motor manufacturer.

Miscellaneous Electrical Formulas

Volts = Amperes x Ohms

Efficiency = $\frac{746 \times \text{Output Horsepower}}{\text{Input Watts}}$

3-Phase Horsepower = $\frac{\text{Volts} \times \text{Amperes} \times \text{Efficiency} \times \text{Power Factor} \times 1.732}{746}$

3-Phase Kilowatts = $\frac{\text{Volts} \times \text{Amperes} \times \text{Power Factor} \times 1.732}{1000}$

3-Phase Amperes = $\frac{746 \times \text{Horsepower}}{1.732 \times \text{Volts} \times \text{Efficiency} \times \text{Power Factor}}$

3-Phase Efficiency = $\frac{746 \times \text{Horsepower}}{\text{Volts} \times \text{Amperes} \times \text{Power Factor} \times 1.732}$

3-Phase Power Factor = $\frac{\text{Input Watts}}{\text{Volts} \times \text{Amperes} \times 1.732}$

Torque (ft. lbs.) = $\frac{\text{Horsepower} \times 5250}{\text{RPM}}$

Kilowatts = 0.746 x Horsepower

Horsepower = 1.341 x Kilowatts



Twin City Fan Companies, Ltd.

Designers & Manufacturers of Air Moving Equipment

5959 Trenton Lane · Minneapolis, MN 55442-3238
Phone (612) 551-7600 · Fax (612) 551-7601 · www.twincityfan.com

November 1999

