

JET FAN TYPICAL DATA

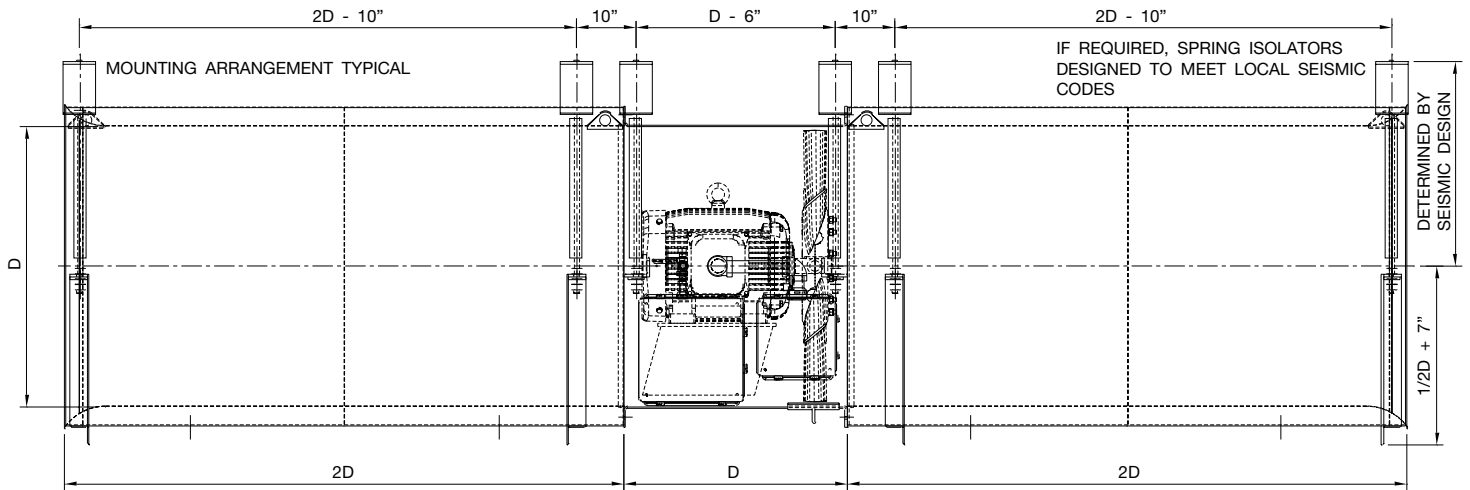

DIMENSIONAL DATA FOR VARIOUS FAN DIAMETERS WITH MAXIMUM THRUST RATING PER FAN DIAMETER

D (in.)	Max Thrust (lbf)	Max RPM (60Hz)	Max Power (Hp)
19-2/3	70	3600	25
22	100	3600	30
25	155	3600	50
28	220	3600	75
31-1/2	284	3600	100
35-1/2	250	1800	60
39-1/2	360	1800	150
44	380	1800	100
49	645	1800	250
55	1015	1800	400
63	770	1200	250

Optional 1D silencers can be provided as well.

For additional special requirements please contact the factory.

TYPICAL IMPELLER CONSTRUCTION

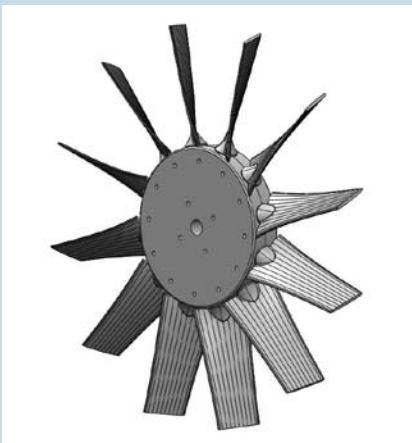

COMPLETE FEA DESIGN WORK
PERFORMED ON ALL UNITS

FULL THRUST / SOUND TESTING

FULL HIGH TEMPERATURE TESTING CAPABILITIES
UP TO 400°C FOR 2 HOURS
WITH AUTOMATED BURN CONTROLS
AND DATA COLLECTION

BUILT IN COMPLIANCE WITH
EUROPEAN STANDARD
EN 12101-3



REPAIR & REBUILD

2335 COLUMBIA PKWY • PULASKI, TN 38478
PHONE: 931-363-2667 • FAX: 931-363-3155

NEW FANS

5959 TRENTON LANE NORTH • MINNEAPOLIS, MN 55442
PHONE: 763-551-7627 • FAX: 763-551-7601

WWW.CLARAGE.COM