

JET FAN TYPICAL DATA

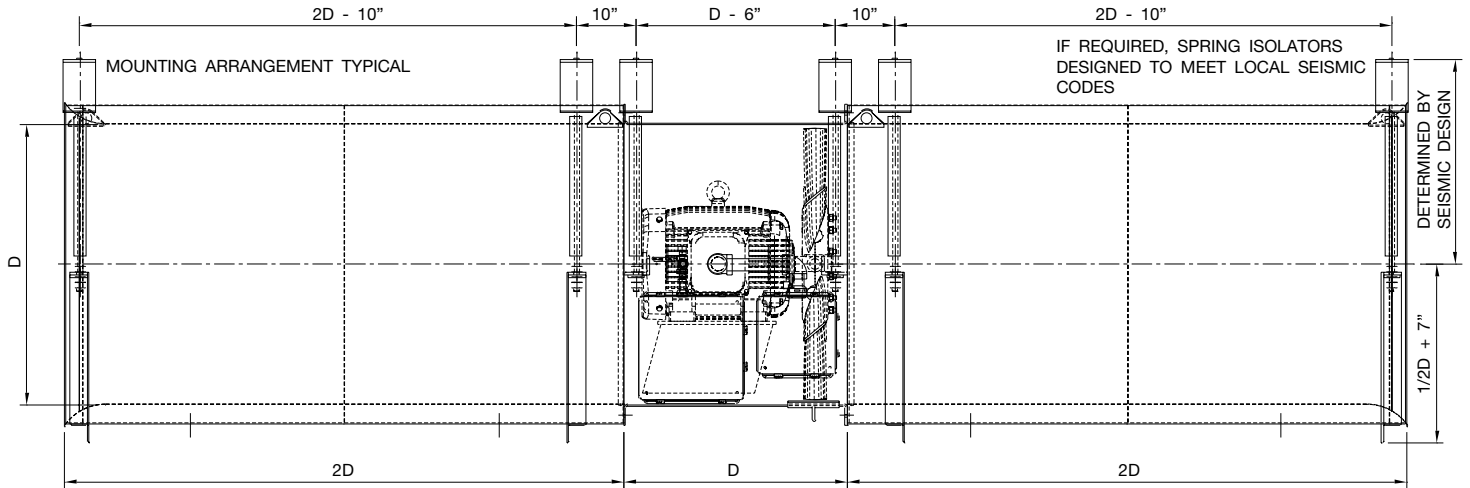

DIMENSIONAL DATA FOR VARIOUS FAN DIAMETERS WITH MAXIMUM THRUST RATING PER FAN DIAMETER

D (mm)	Max Thrust (N)	Max RPM (50Hz)	Max Power (kW)
500	235	3000	11
560	370	3000	22
630	580	3000	30
710	840	3000	37
800	1045	3000	45
900	775	1500	30
1000	1185	1500	55
1120	1280	1500	45
1250	2150	1500	90
1400	3040	1500	132
1600	2570	1000	110

Optional 1D silencers can be provided as well.

For additional special requirements please contact the factory.

TYPICAL IMPELLER CONSTRUCTION

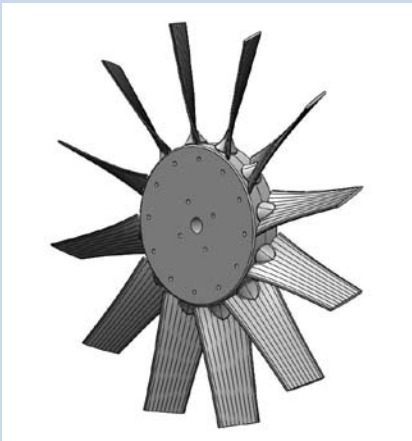

COMPLETE FEA DESIGN WORK
PERFORMED ON ALL UNITS

FULL THRUST / SOUND TESTING

FULL HIGH TEMPERATURE TESTING CAPABILITIES
UP TO 400°C FOR 2 HOURS
WITH AUTOMATED BURN CONTROLS
AND DATA COLLECTION

BUILT IN COMPLIANCE WITH
EUROPEAN STANDARD
EN 12101-3



REPAIR & REBUILD

2335 COLUMBIA PKWY • PULASKI, TN 38478
PHONE: 931-363-2667 • FAX: 931-363-3155

NEW FANS

5959 TRENTON LANE NORTH • MINNEAPOLIS, MN 55442
PHONE: 763-551-7627 • FAX: 763-551-7601

WWW.CLARAGE.COM